

INSTALLATION & OPERATION MANUAL

Installation & Operation Manual

MINI VRF (CHR/CSREA series)

Contents

Safety Precautions	5
Installation of ODU	6
Dimensions.....	6
Installation space.....	7
Handling	10
Placement	10
Installation of refrigerant piping	12
Caution:	12
Diameters of refrigerant piping.....	13
Installation of branch pipes	14
Limits for refrigerant piping.....	18
Air tightness test, vacuuming and supplementing refrigerant	19
Air tightness test.....	19
Vacuuming	19
Supplementing refrigerant.....	20
Electrical control installation	21
Wiring cautions.....	21
Wiring specifications	23
Electrical wiring	24
Communication wiring.....	24
Illustration on control board of ODUs.....	Ошибка! Закладка не определена.
Code settings	Ошибка! Закладка не определена.
Settings of relevant keys	Ошибка! Закладка не определена.
Settings of relevant buttons:	Ошибка! Закладка не определена.
Trial Operation	Ошибка! Закладка не определена.
Before trial operation.....	Ошибка! Закладка не определена.
Trial Operation.....	Ошибка! Закладка не определена.
Trial operation check.....	Ошибка! Закладка не определена.

No.:

Application Form for Debugging Household Inverter VRF Air Conditioning Unit by Installer		
Full name of installer: _____		
Address of installer: _____		
Owner's name or employer: _____		
Person to contact: _____ Tel: _____		
Installation site: _____ Province City _____		
Unit model: _____		
IDU bar code: _____		
ODU bar code: _____		
Distributor: _____	Person to contact: _____	
Tel: _____	Fax: _____	
Installer: _____	Person to contact: _____	
Tel: _____	Fax: _____	
The following items are to be filled by the installer correctly, so that the debugging can be arranged in due time. In case the form contents are different from the real situation, causing the experts unlikely to conduct debugging on site, the installer must be liable for labor and travelling expenses incurred to the debugging experts.		
Contents to be Checked and Confirmed by Installer		
Before installation, ask the installer to carefully read through the manuals and relevant requirements attached to the unit.		
1. Check installation position		
a. Whether heat dissipation and ventilation for ODU meets requirements for distance	Yes ()	No ()
b. Whether ODU is installed on a base firmly and with vibration damping measures applied	Yes ()	No ()
c. Whether IDU is provided with vibration damping measures and properly fastened	Yes ()	No ()
d. Whether there is space for maintenance	Yes ()	No ()
2. Check electrical system before installation		
a. Whether air switch capacity and power wire diameter meet unit requirements	Yes ()	No ()
b. Whether correctly wired and whether wiring terminal is pressed and completely connected	Yes ()	No ()
c. Whether neutral line and grounding wire are connected in accordance with electrical codes	Yes ()	No ()
d. Whether the distribution of control wire and power wire meets anti-interference requirements	Yes ()	No ()
e. Whether the length of control wire and power wire is proper	Yes ()	No ()
3. Check refrigerating system before installation		

a. Whether refrigerant duct meets factory requirements in terms of its diameter and thickness	Yes ()	No ()
b. Whether the length of refrigerant duct meets relevant requirements	Yes ()	No ()
c. Whether added nitrogen for welding refrigerant duct to protect air conditioning unit	Yes ()	No ()
d. Whether cleaned refrigerant duct	Yes ()	No ()
e. Whether used nitrogen for holding pressure to test leakage	Yes ()	No ()
f. Whether vacuumized refrigerating system against installation manual	Yes ()	No ()
g. Whether supplemented refrigerant according to standard	Yes ()	No ()

Application Form for Debugging Household Inverter VRF Air Conditioning Unit by Installer

4. Check air duct system before installation

a. Whether the installation of air duct system is designed by professionals	Yes ()	No ()
b. Whether external residual pressure matched actual resistance of air duct	Yes ()	No ()
c. Whether air duct system is provided with static pressure box for air supply and return	Yes ()	No ()
d. Whether air flow organization of indoor air supply and return is reasonable	Yes ()	No ()
e. Whether air duct is insulated	Yes ()	No ()
f. Whether air valve is reasonably set	Yes ()	No ()
h. Whether return air inlet or IDU is equipped with filter and make sure they are clean	Yes ()	No ()
i. Whether equipped with air return duct in the case of ceiling air return	Yes ()	No ()
j. Whether there is fresh air device	Yes ()	No ()
k. Air supply and return mode: 1 bottom air supply and side air return: 2 side air supply and side air return	Yes ()	No ()

5. Check indoor condensate water system before installation

a. Pour water into drain pan to check whether condensate water could be discharged smoothly and whether there is leakage	Yes ()	No ()
b. Check whether condensate water pipe is tightly sealed to prevent condensation on the surface of pipe	Yes ()	No ()
c. Whether water trap is designed in accordance with the manual attached to the unit	Yes ()	No ()

6. Preparation before debugging

a. Whether power voltage is $\pm 10\%$ of the normal range	Yes ()	No ()
b. Ensure the power is not temporary	Yes ()	No ()
c. Whether the clients and Party A's inspection experts are in place in time	Yes ()	No ()
d. Whether there are sufficient facilities (ladder and lifting table etc.) to ensure normal work of operators	Yes ()	No ()
e. Whether the unit is pre-heated for 24 hours before powering on for debugging	Yes ()	No ()

7. Other circumstances

Date of requiring debugging: _____ Before date _____ month _____ year _____

Applicant (seal):

Signature: Date:

Safety Precautions

⚠ Caution: Read this manual carefully before installation and use of the unit.

The following standard is applied to this product:

GB/T 18837-2015 GB4706.1-2005

This installation manual is applied to TICA TIMS series household R410A inverter VRF air conditioning units. The manual is subject to change based on improvement on air conditioners without further notice.

Preparation before installation

- Installation shall be left to a licensed professional. Users shall not install, repair or displace the air conditioning unit by themselves.
- Be sure to use a dedicated power circuit. Make sure the supply voltage fluctuates within $\pm 10\%$ of rated voltage. Power supply should be separate from welding transformer because the latter may cause large voltage fluctuation.
- Get a licensed electrician to install the unit according to national and local power standard, and to check whether line capacity meets requirements and whether power lines are loose or damaged.
- "Electrical control schematic diagram" is attached to the back side of cover plate of ODU control box. Please keep the manual properly for further reference.

Precautions during installation

- Do not touch heat exchanger fins. Otherwise, it may cause damage to the fins or reduced performance for the unit or finger injury.

- The cover plate for control box must be fastened to prevent incoming of dust and water. The electrical parts must be waterproof and away from water sources, otherwise electric shock or fire may be caused.
- After installation, be sure to make an air tightness check whether there is pipeline leakage.

Precautions for using R410A refrigerant devices

- Please supplement refrigerating system with liquid refrigerant. In the case of gaseous refrigerant, composition of refrigerant in the system may change.
- Do not mix into other refrigerants.
- Do not use the following tools ever used for common refrigerants (such as R22): pipeline pressure test devices, filling hoses, leakage detection devices, refrigerant filling base, and refrigerant recovery devices.
- Make sure to use vacuum pump dedicated for R410A series.

Precautions at trial operation

- When the system is powered on for the first time or after being left unused for

a long time, ODU power must be connected 24 hours before use. Otherwise, the compressor may be burnt (make sure the air conditioner is in standby mode at the seasons they are needed most).

Do not turn on the air conditioner when the panel or protection screen is removed. The moving parts inside the air conditioner may hurt people or other objects.

Do not touch refrigerant pipeline during operation or just at the end of operation.

The pipeline of the air conditioner may be very hot or cold during its operation, which may lead to scald or frostbite.

Do not turn off power immediately after the unit stops. Wait at least for five minutes, otherwise water leakage may occur.

Please cut off general power supply during seasons the air conditioners are not used, so as to prolong the service life and save energy.

All the IDUs and ODUs of the same system must be supplied with power simultaneously.

Installation of ODU

Standard model

ODU capacity is indicated by its cooling capacity with the unit kW

Model	TIMS080 CHR	TIMS100 CHR	TIMS112 CHR	TIMS 125CHR	TIMS 140CHR	TIMS 160CHR	TIMS180 CSREA	TIMS200 CSREA	TIMS224 CSREA
Cooling capacity	8.0kW	10.0kW	11.2kW	12.5kW	14.0kW	16.0kW	18.0kW	20.0kW	22.4kW
Maximum number of IDUs	4	5	5	6	7	8	9	10	11
Model	TIMS252 CSREA	TIMS285 CSREA	TIMS335 CSREA						
Cooling capacity	25.2kW	28.5kW	33.5kW						
Maximum number of IDUs	13	15	16						

The suffix 'A':3N-380V 50Hz

Dimensions

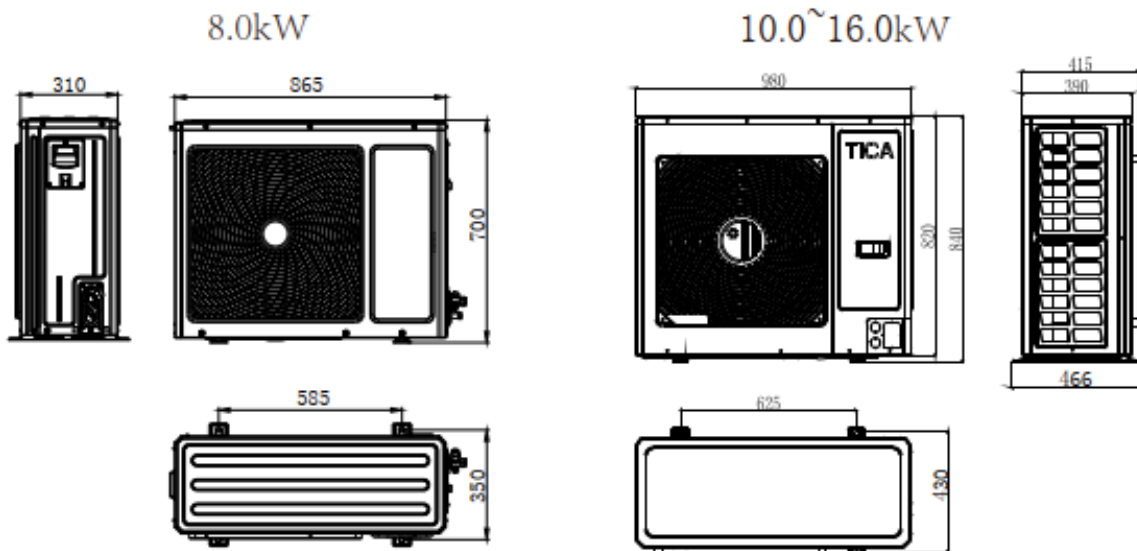

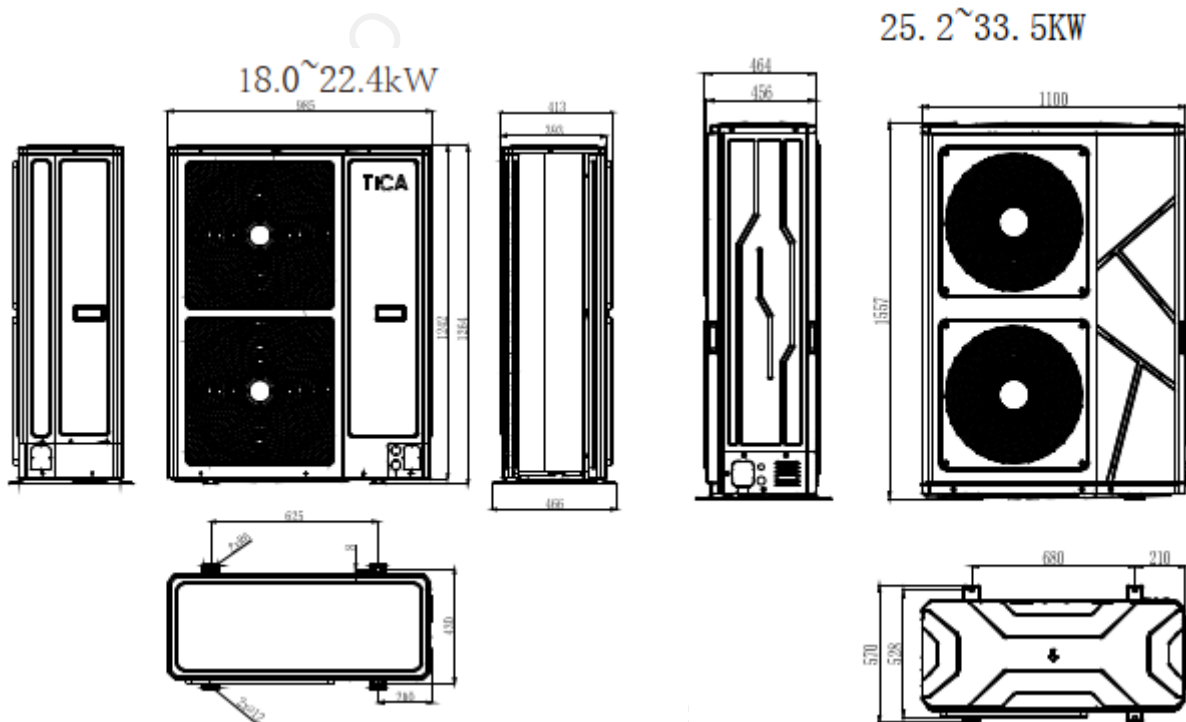

Installation of ODU

Installation space

Requirements for installation position

- The installation position shall have sufficient strength to bear the unit weight and its vibration during operation. If the ODU is installed on a roof, make sure the roof is strong enough and water-proof.
- The ODU shall be installed in a well ventilated place to ensure good heat exchange.
- Places unsuitable for installation:
 - ▲ The place where acid or alkaline substance or corrosive gas (e.g., sulfur dioxide and hydrogen sulfide) may be produced, easily corroding the unit and leading to refrigerant leakage.
- Places where air conditioning units must not be installed:
 - ▲ The place where flammable gas or volatile combustibles may be produced. If flammable gas leaks and accumulates around the unit, the unit may explode.
 - ▲ Do not install the ODU where it is exposed directly to strong wind or typhoon. When conditions permit, add auxiliary equipment to prevent water, snow or direct sunshine.

Requirements for ODU installation space:

- Make sure there is enough space above the unit.



- The side with TICA symbol attached shall be the front side of ODU.
- The space required for installing or maintaining an ODU is shown in the following figure.

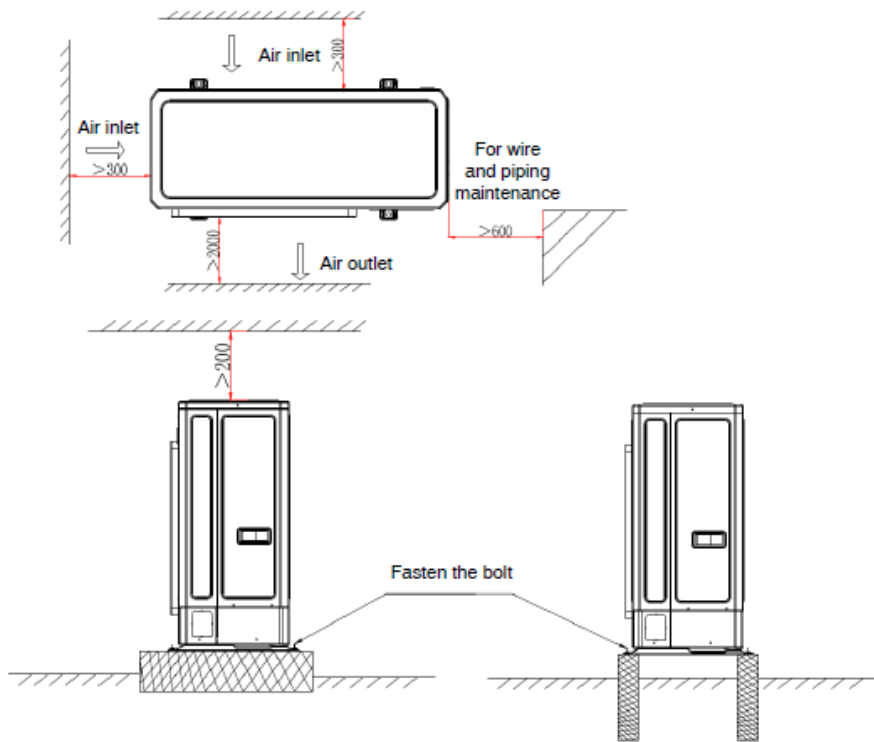

Installation of ODU

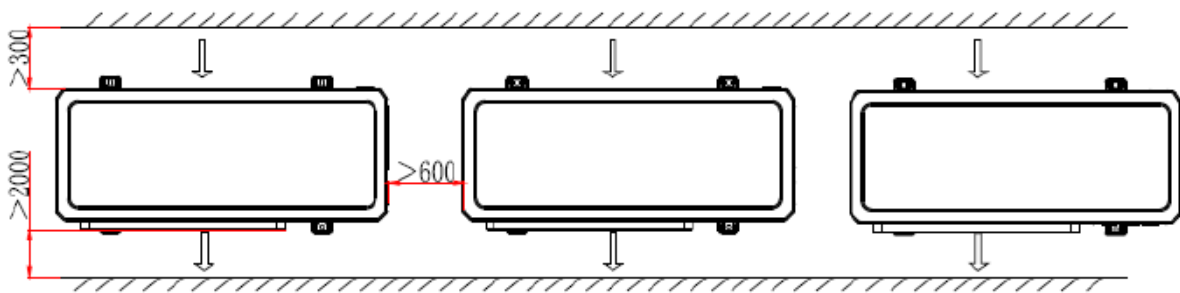
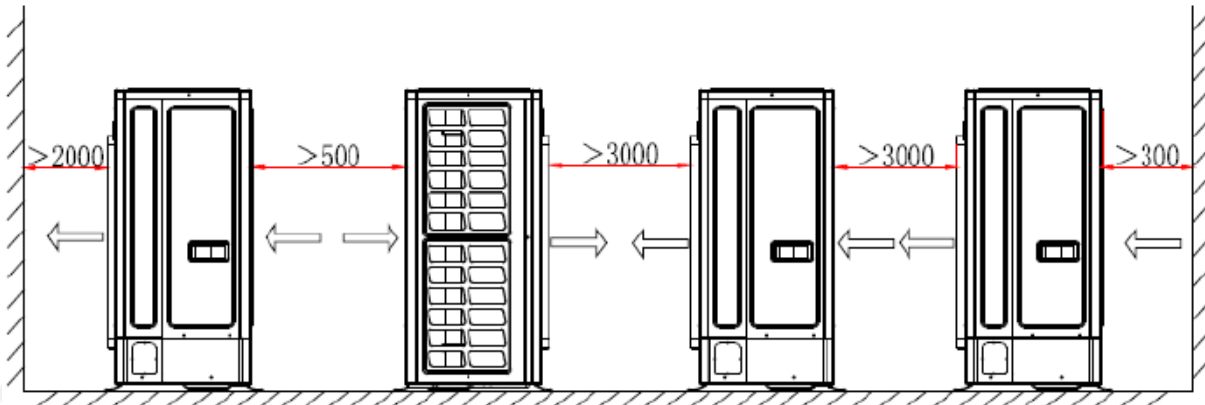

Installation of ODU

Handling

Caution:

- Fragile and handle with care.
- The degree of inclination shall not exceed 30° while handling (do not put the unit on its side).
- Keep heat exchange fins safe while handling and installing the unit. In case of any damages, please use fin comb to fix it up.
- Properly dispose of packaging bags and prevent kids from playing with them.

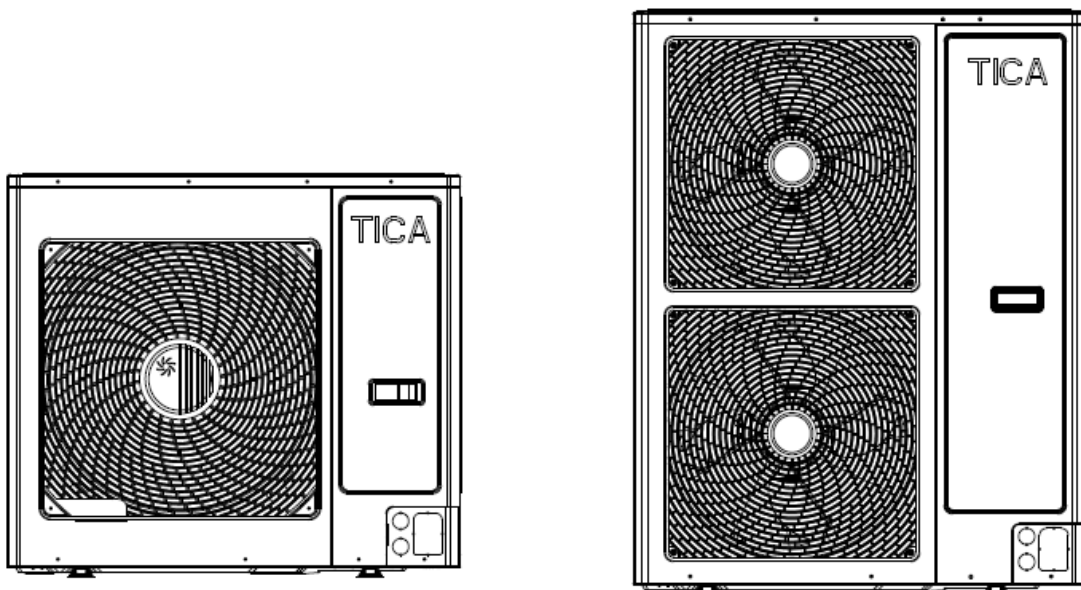

- Use forklift to handle: be careful when inserting the fork into the pocket at the bottom, and prevent fork from damaging the unit or the unit bottom.
- Use crane to handle: tighten hoisting rope according to what is shown in the figure, and keep the unit weight even during hoisting.
- Use two hoisting ropes at least 8 m long and about 20 mm in diameter to support the unit weight. Do not use tying band of the unit for handling.
- After the wooden framework is removed: use paper or cloth as pad between hoisting rope and the unit to prevent damages to the unit body.

Placement

- Make sure the ODU is placed firmly at a level place to prevent vibration and noises.
- Use a base larger than the width of ODU's support legs (66 mm) to support the unit.
- The shock-absorbing pads shall cover the entire bearing surface of the base.
- The unit base shall be at least 200 mm higher above the ground.
- Around the base there should be drain to ensure that the condensate water generated during operation could flow out.

Installation of ODU

- Concrete foundation: the foundation shall be above the ground for at least 150 mm.

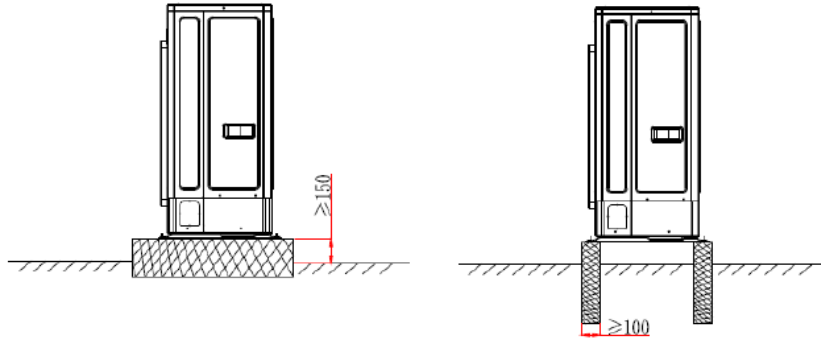

- Use anchor bolts, nuts and pads to fasten the ODU tightly to the base. Caution: shock-absorbing pads need to cover the entire bottom of the unit, and the pad thickness is greater than or equal to 20 mm.
- For anti-corrosive models: use rubber pads. If the nut joints get loose, the unit will not be corrosion proof.

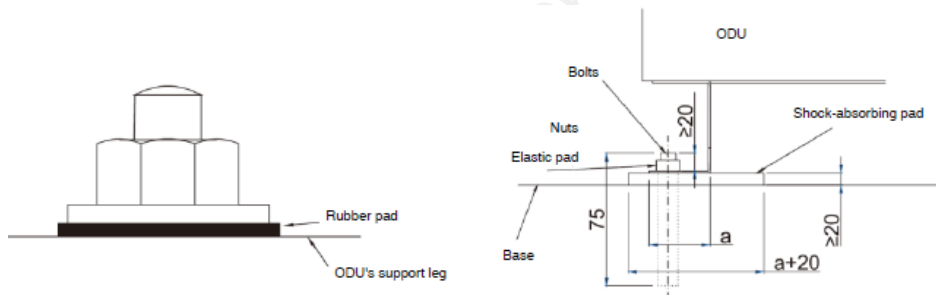

Installation of refrigerant piping

Caution:

- Use clean piping that is free from dust, moisture or any other substances.
- Store all the pipelines needed for installation indoors, and keep two ends of pipelines sealed till welding.
- Pass copper pipes into the holes at wall and seal the holes to prevent dirt coming in.
- Do not do ODU piping work on rainy days, lest that moisture and dirt would enter the pipelines.
- Try to reduce bended piping and use bends with larger radius.
- When connecting refrigerant piping, the stop valve of ODU shall be closed completely after refrigerant piping between ODU and IDU is done, and refrigerant leakage test and vacuumizing process are finished.

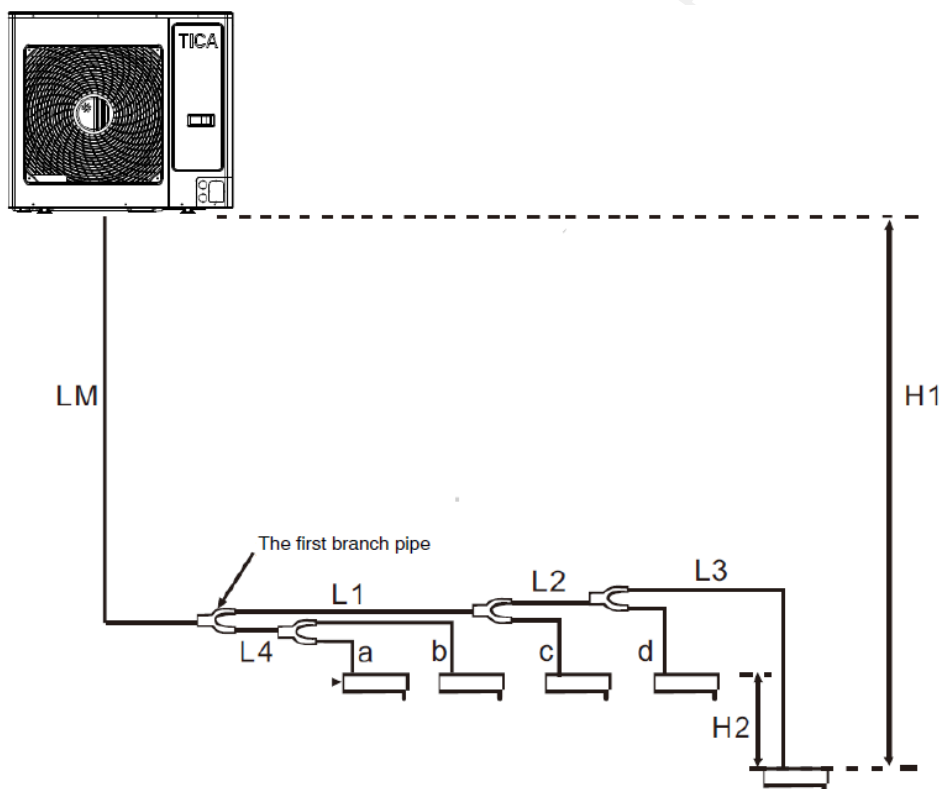

Installation of refrigerant piping

	Limits (allowable values)	Remarks
H1*1	When the ODU is at the upper position: ≤ 20 m When the ODU is at the lower position: ≤ 15 m	
H2*1	≤ 8 m	
The longest piping distance from the first branch pipe	≤ 20 m (equivalent)	L1+L2+L3
LM	≤ 50 m (actual)	When the equivalent length of liquid side and gaseous side is greater than or equal to 90m, increase the length of main pipe at gaseous side
The longest piping distance	≤ 60 m (actual), ≤ 70 m (equivalent)	LM+L1+L2+L3
L3	≤ 15 m (equivalent)	a, b, c, d, L3
Total length	Total length ≤ 100 m (actual)	LM+L1+L2+L3+a+b+c+d

*1: Contact TICA's engineers when exceeding the above limits.

*2. The total refrigerant quantity of the unit should not be greater than 6.5 kg, otherwise the unit may fail to operate safely and reliably. Please consult TICA's engineers for details.

Diameters of refrigerant piping

The copper pipe for main pipelines in the figure shall have the sizes chosen from the following table based on the total capacity of ODUs at the upper reaches

ODU Capacity	Air side + liquid side equivalent length < 90 m		Air side + liquid side equivalent length ≥ 90 m	
	Liquid pipe (mm)	Gas pipe (mm)	Liquid pipe (mm)	Gas pipe (mm)
8.0kW	9.52	15.88	9.52	15.88
10.0kW	9.52	15.88	9.52	15.88
11.2kW	9.52	15.88	9.52	15.88
12.5kW	9.52	15.88	9.52	15.88
14.0kW	9.52	15.88	9.52	19.05
16.0kW	9.52	15.88	9.52	19.05
18.0kW	9.52	19.05	9.52	19.05
20.0kW	9.52	19.05	9.52	19.05
22.4kW	9.52	19.05	9.52	19.05
25.2kW	12.7	22.2	15.88	25.4
28.5kW	12.7	22.2	15.88	25.4
33.5kW	12.7	25.4	15.88	28.5

Installation of refrigerant piping

- The piping between the last-level branch pipe and IDU shall have the same sizes with IDU piping.
- The piping between branch pipes shall be based on the total capacity of downstream IDUs connected to the piping.

Total capacity of connected IDUs	Liquid pipe specifications (mm)	Air pipe specifications (mm)
$X < 16.8$	$\phi 9.52$	$\phi 15.88$
$16.8 \leq X < 22.5$	$\phi 9.52$	$\phi 19.05$
$22.5 \leq X < 33.0$	$\phi 12.7$	$\phi 22.2$
$33.0 \leq X$	$\phi 12.7$	$\phi 25.4$

Remarks: The size of the piping between branch pipes shall not be greater than that of cooper pipe at Place A in the figure above.

Installation of branch pipes

- Branch pipes shall be selected based on the total capacity of downstream IDUs connected:

Total capacity of downstream IDUs connected to branch pipes	Model of branch pipes
$X < 16.8$	TBP4022TA
$16.8 \leq X < 22.5$	TBP4022TA
$22.5 \leq X < 33.0$	TBP4033TA
$33.0 \leq X$	TBP4072TA

The model of branch pipe components and the diameter of main pipe and branch pipe shall be confirmed against working drawings and installation instructions. There should not be sharp turns (90° angle) or other branch pipe components falling within 500 mm of branch pipe components. The straight pipe distance between two adjacent branch pipes shall not be less than 1000 mm.

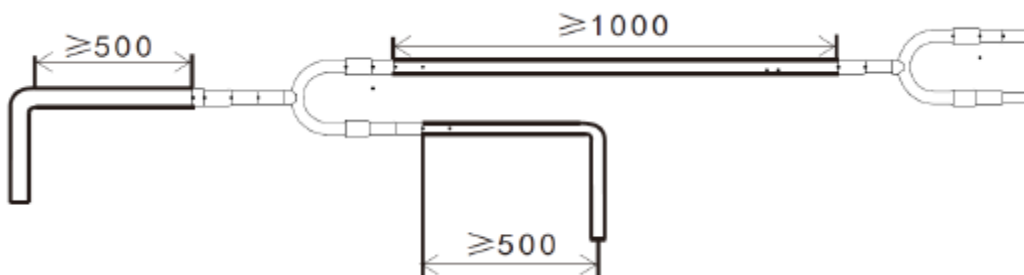

Installation of refrigerant piping

⚠ Branch pipes can be vertically or horizontally installed and as close as possible to the IDU.

When installed horizontally, the angle shall be between $\pm 15^\circ$.

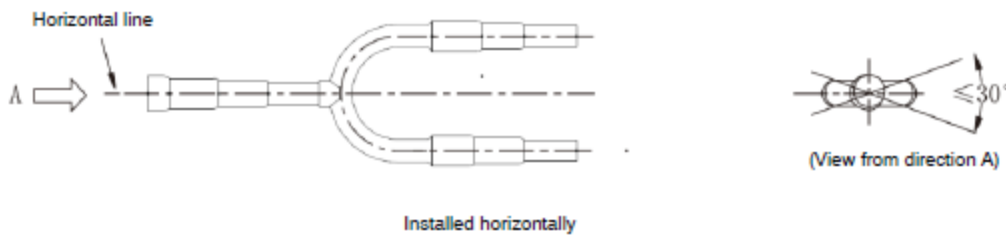

See the following figure when branch pipes are installed vertically.

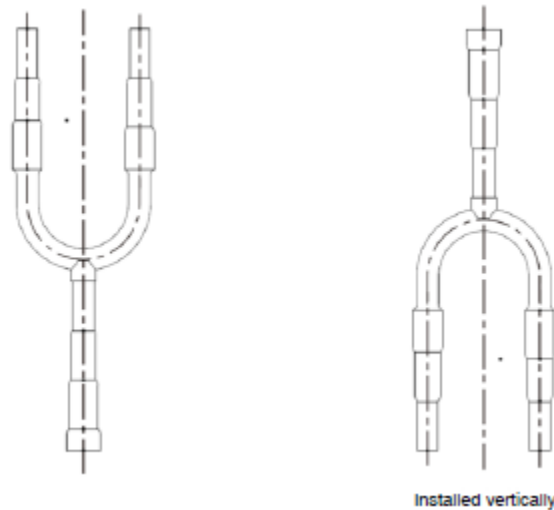

- Size of branch pipes:
TBP4022TA

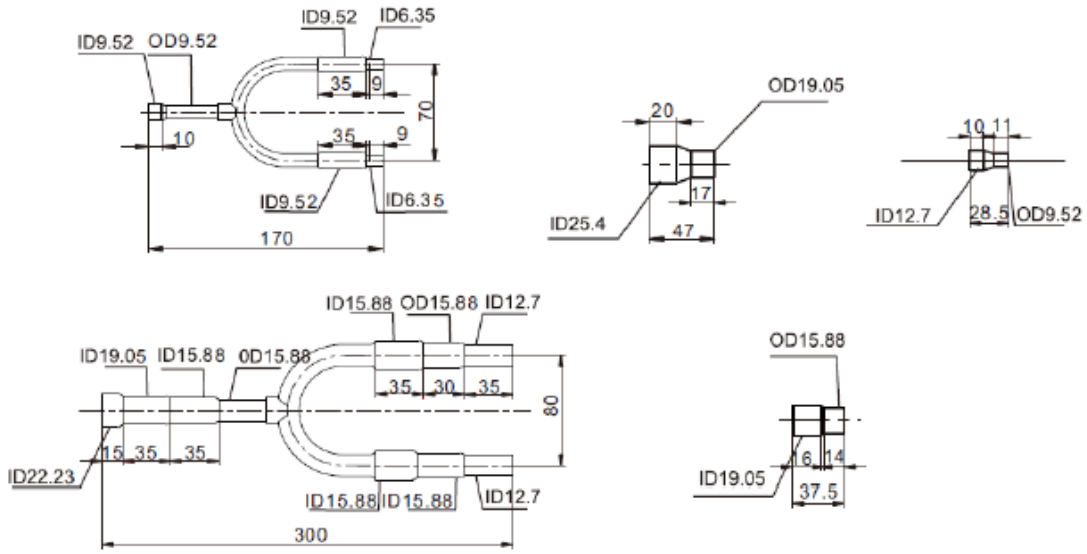

TBP4033TA

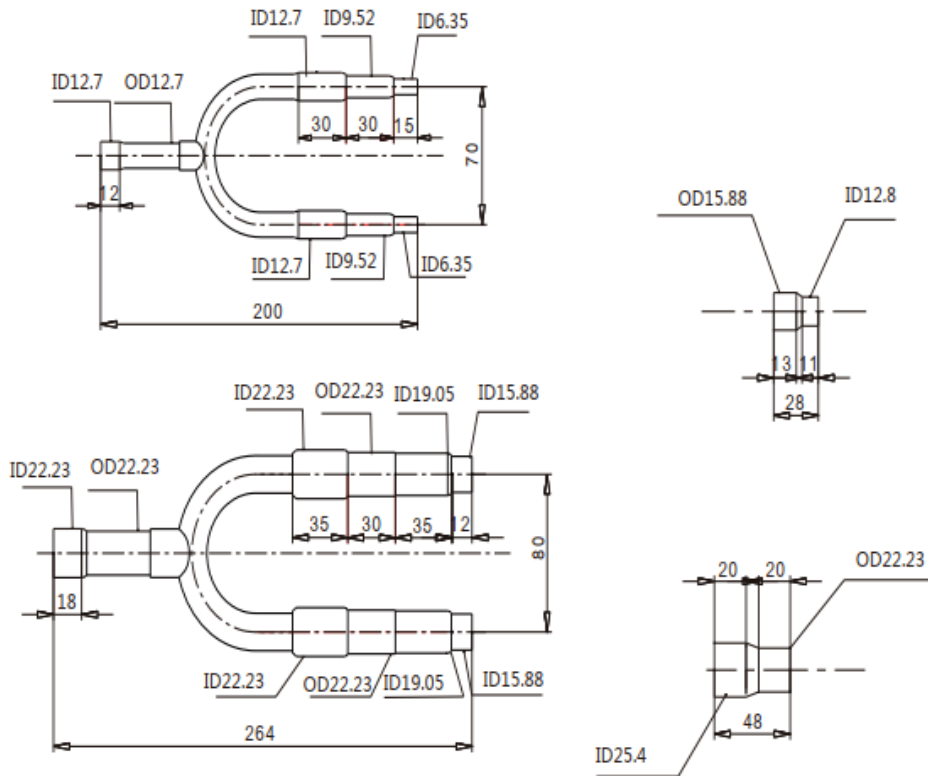

TBP4072TA

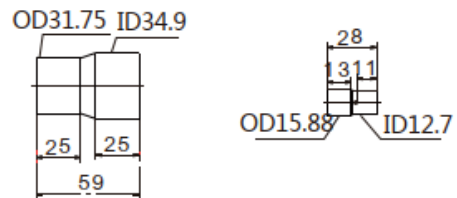
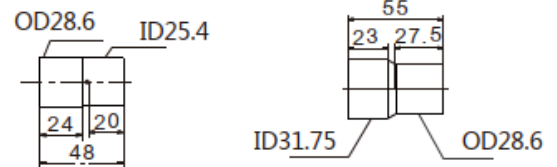
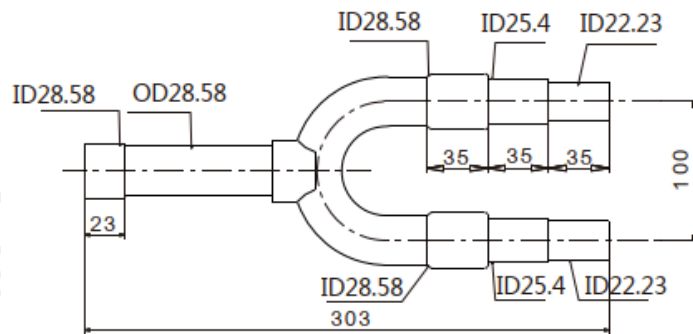
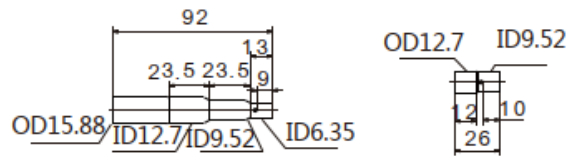
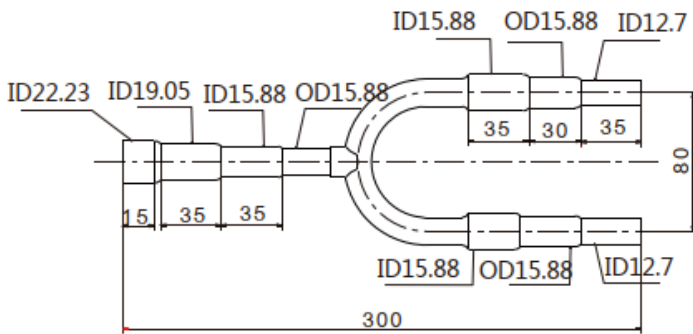

Installation of refrigerant piping

Limits for refrigerant piping

Capacity combination

$$80\% \leq \frac{\sum \text{Rated cooling capacity of IDU}}{\text{Rated cooling capacity of ODU}} \leq 130\%$$

Remarks: It is recommended that the above value shall not be greater than 100% when selecting models. For scenarios with lower simultaneous usage coefficient, the above value may exceed 100%.

Unit capacity		Single unit
Maximum actual (equivalent) piping length		≤ 80 (100) m
Level difference	Level difference between IDU and ODU	H1 ≤ 20 m (when the ODU is at the upper position) H1 ≤ 15 m (when the ODU is at the lower position)
	Level difference among IDUs	H2 ≤ 8 m

Note (1): Equivalent length is the converted length after taking into account of pressure losses at elbows.

Equivalent length = actual pipe length + number of elbows × equivalent length of each elbow

Equivalent length of every place of branch pipe is 0.5 m, and please refer to the following table for equivalent length of elbows.

Pipe diameter	Equivalent length
	Elbow (m)
φ 9.52	0.18
φ 12.7	0.2
φ 15.88	0.25
φ 19.05	0.35
φ 22.23	0.4
φ 25.4	0.45
φ 28.6	0.5
φ 31.8	0.55

Precautions when breaking through the knockout

- Do not damage the unit shell when trying to break through the knockout.
- Ensure the hole to be trimmed after being broke through with a hammer, and protect it from corrosion by painting.
- When passing the wire through knockout, put grommet in the hole or wrap wires with adhesive tape for protection.

Air tightness test, vacuuming and supplementing refrigerant

For TICS units, vacuum pump, pressure gauge, compound pressure gauge and charging hose used for R410A refrigerant are different from those used for R22 refrigerant. Make sure to use R410A dedicated tools.

Air tightness test

Caution:

- After piping work is completed, make sure to do air tightness test for IDU and piping.
- Do not use flammable gas or air (oxygen) as pressurized gas, otherwise fire or explosion may be caused; use nitrogen only.

Steps:

Step 1: Increase pressure by 0.3 MPa for three minutes, and check whether there are major leakage points.

Step 2: Continue to increase pressure to 1.5 MPa for three minutes, and check whether there are minor leakage points.

Step 3: Continue to increase pressure to 4.0 MPa for 24 hours, and check whether there are micro leakage points

Vacuuming

Caution:

- Use vacuum pump with volume above 4 L/s. The vacuum degree must support -755 mmHg and lower.
- To prevent lubricating oil from flowing in the reverse direction to refrigerant system, use vacuum pump with electronic one-way valve.

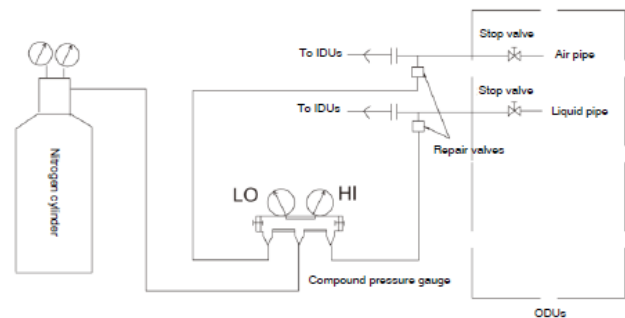

⚠ Use nitrogen in air tightness test instead of oxygen, flammable and toxic gas, or water. Use R410A dedicated pressure gauge, with measuring range above 4.5 MPa. Connect high pressure pipe and low pressure pipe and increase pressure for them at the same time, without connecting to ODU. After passing air tightness test, if not used immediately, release system pressure to 0.2-0.3 MPa and then seal it.

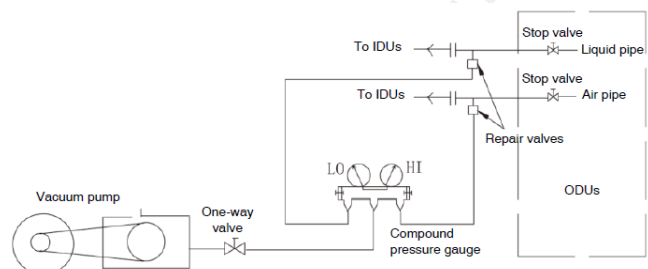

Air tightness test, vacuuming and supplementing refrigerant

- Vacuum air pipe and liquid pipe at the same time. Before vacuuming, make sure again that stop valves at air and liquid sides of IDUs are closed.
- Use R410A dedicated tools, such as pressure gauge and liquid supplementing pipe.

Supplementing refrigerant

Principles:

Before delivery, the ODUs have been filled with a certain amount of refrigerant, but which cannot meet the needs of extended pipes. So refrigerant has to be added according to the actual length of refrigerant piping at installation site.

Steps:

- Close compound pressure gauge, replace vacuum pump with filling tank connected with charging pipe. Make sure the air is drained completely, and connect the joints of filling tanks and put the tank mouth down on the platform scale.
- Set the quantity to be filled at the electronic scale, and successively open the valve of filling tank and valve of compound pressure gauge to fill the system with refrigerant. When reaching the limits, immediately close valve of filling tank and disconnect connection pipes.

Caution:

- For refrigerant tank with siphon: the tank needs not to be put upside down because the siphon can reach the tank bottom.
- If using R410A filling tank without siphon, make sure the tank is put upside down in the filling process, which is shown as below

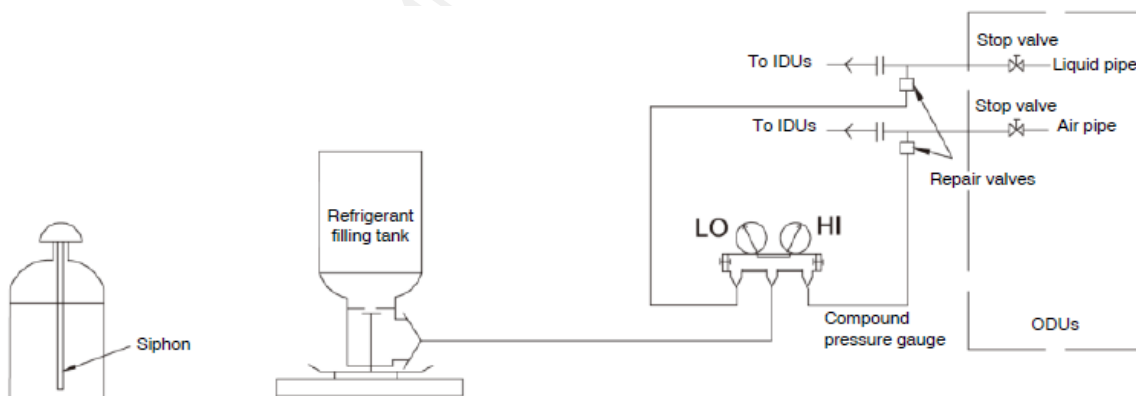

Calculation of amount to be filled (R410A):

Liquid pipe diameter (mm)	6.35	9.52	12.7	15.88	19.05	22.2
Supplemented refrigerant quantity (g/m)	22	54	110	170	260	360

Supplemented refrigerant quantity = Σ liquid pipe length at various diameters \times supplemented refrigerant quantity per meter \times 0.8

Electrical control installation

Wiring cautions

Cautions for power wiring

- Use copper wire as power wire and do not make it too tight.
- All the IDUs and ODU's of the same system must be supplied with power simultaneously.
- The distribution box shall be provided with a set of electric leakage protection device and air switch for each module.
- Make sure all the earth lines of the unit are connected to ground securely. Do not connect earth lines to lightning devices, telephone line, gas pipe or tap water pipe. Improper grounding may cause electrical shock or fire.

Cautions for communication line wiring

- TICS series household inverter VRF air conditioning unit has both high voltage (power) line and control (communication) line. Do not connect power line to the connecting terminal of communication cables!
- The total length of communication line is less than 1000 m. The shielding layer of communication line must be connected to earth lines of each module and IDUs securely.

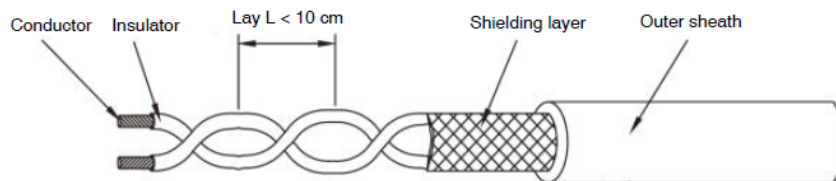

Legends of shielded twisted pair

- Communication lines are well connected before power on.
- Do not remove the power plug with power on, lest the communication chips would be damaged. To prevent high voltage signal from disturbing control signal, shielded twisted pair must be used.
- Try to select shielded twisted pair with dense shielding layers and smaller lay. Control signal has two polarities A and B, and different polarities cannot be connected, otherwise communication failures may be caused;

As shown in the figure below.

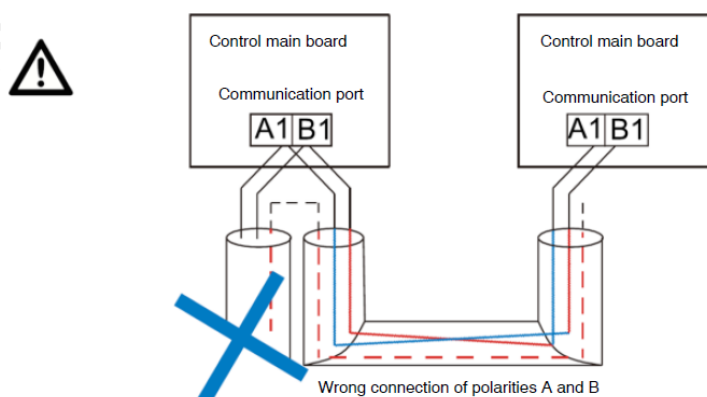



- When power line is parallel with communication line, they shall be covered by respective conduits and kept at some distance away.

Electrical control installation

Wiring specifications

Notes:

- As wires need to be bent during installation process, it is recommended to use flexible wires, otherwise installation may fail.
- The parameters in the table below are corresponding to multiple strands of flexible copper wires. If other wires are selected, please refer to electrician's manual based on wiring current provided in the table.
- For safety purpose, do not carry out wiring work based on rated current, for the operating conditions may be varied with seasons.

Table of ODU wiring specification

ODU model	Power supply	Voltage range (V)	General power line	Fuse circuit breaker (A)	Communication line
8.0kW	Single phase 220V/50Hz	198/242	3×4 mm ²	25	0.75-1.25 mm ² polyethylene shielded twisted pair
10.0kW		198/242	3×6 mm ²	32	
11.2kW		198/242	3×6 mm ²	32	
12.5kW		198/242	3×6 mm ²	32	
14.0kW		198/242	3×6 mm ²	40	
16.0kW		198/242	3×6 mm ²	40	
18.0kW		198/242	3×6 mm ²	40	
18.0kW	Three phase 380V/50Hz	342/418	5×4 mm ²	20	
20.0kW		342/418	5×4 mm ²	20	
22.4kW		342/418	5×4 mm ²	20	
25.2kW		342/418	5×6 mm ²	30	
28.5kW		342/418	5×6 mm ²	30	
33.5kW		342/418	5×6 mm ²	30	

Note: If the power cord is damaged, it must be replaced by a professional from the manufacturer, its maintenance department or similar in order to avoid danger. For parts used outdoors, the power cord should not be lighter than the neoprene armored flexible cord. If the fuse is damaged, it must be replaced by a professional (fuse size: 10A 250V)

Electrical control installation

Electrical wiring

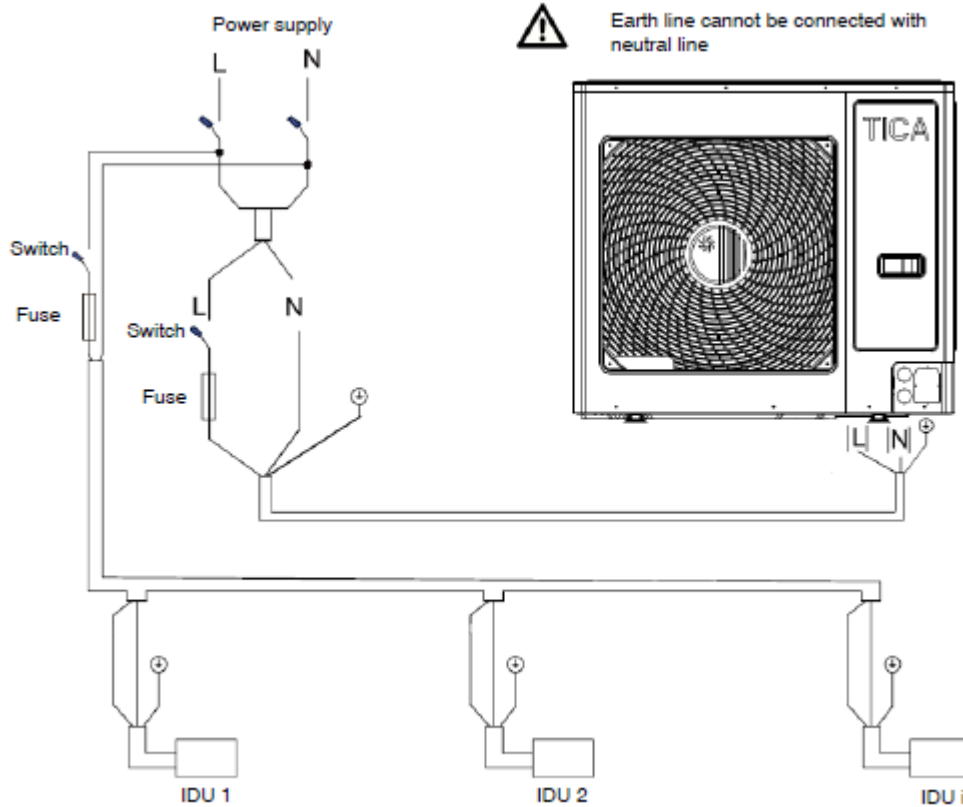

Communication wiring

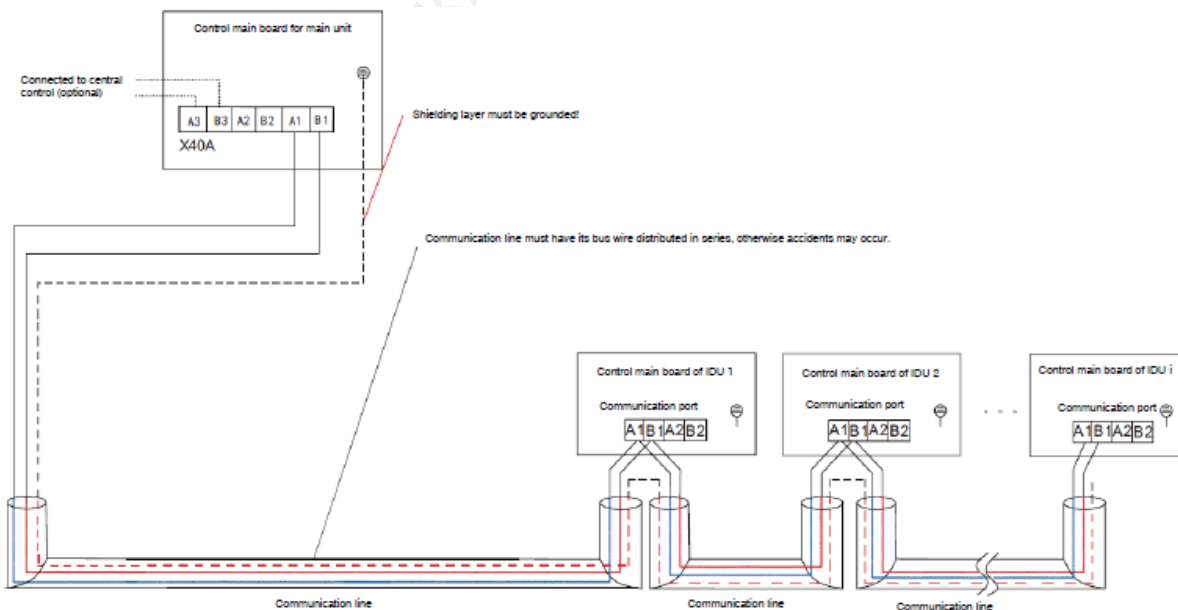

ODU Control Panel

Mechatronic control panel (8.0 kW and 10.0 kW)

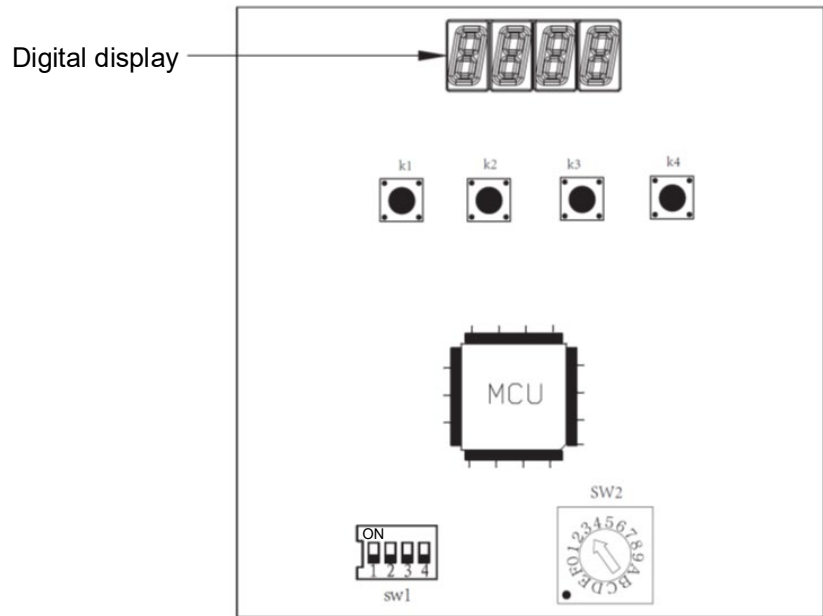

Code settings

Notes:



- '0' for the status above, and '1' when dialed to the "ON" position.
- Description on ODU address setting: based on the specific situation after installation is completed.
- The unit must be powered on again after the DIP switch is reset.
- 0 indicates normal, while 1 indicates silent mode for No. 4 switch.**

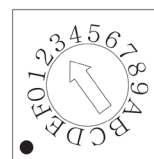

SW2

- SW2: DIP switch of ODU capacity

Cooling Capacity (kW)	SW2
8.0	2
10.0	3
11.2	4
12.5	5
14.0	6
16.0	7

ODU capacity code has been set properly before delivery. Please check whether the setting is right.

ODU Control Panel

11.2 kW – 33.5 kW

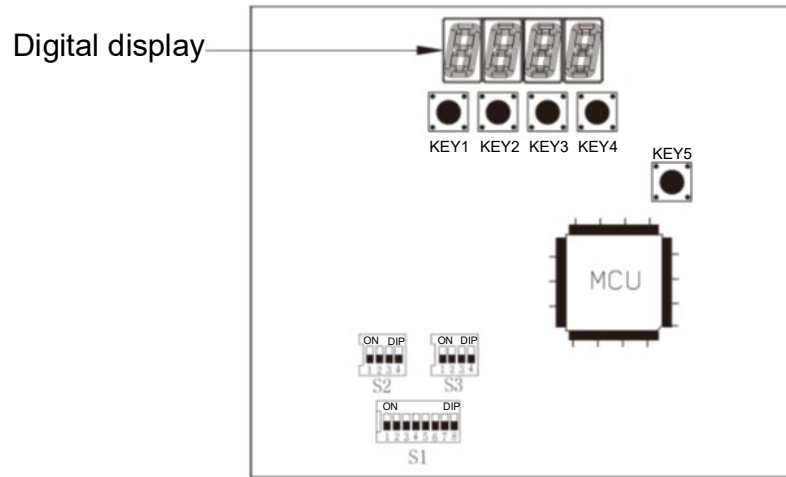

Code settings

S1: model setting

BIT5	BIT6	BIT7	BIT8		
Single phase: 0	0	0	0	CHT	BEDC
	0	0	1	CHR	Reserved
	0	1	0	CHTF	Reserved
	0	1	1	CHRF	Reserved
	1	0	0	DHTF	BEDC
	1	0	1	DHRF	Reserved
	1	1	0	Reserved	Reserved
	1	1	1	Reserved	Reserved
Three phase: 1	0	0	0	CHTA	Reserved
	0	0	1	CHRA	BERA
	0	1	0	CHTAF	Reserved
	0	1	1	CHRAF	BERA
	1	0	0	DHTAF	Reserved
	1	0	1	DHRAF	Reserved
	1	1	0	Reserved	Reserved
	1	1	1	Reserved	Reserved

ODU Control Panel

S2 reserved:

BIT1	BIT2	BIT3	BIT4	Remarks	Value
Reserved	Reserved	Reserved	Reserved	/	/

S3: DIP switch of ODU capacity

BIT1	BIT2	BIT3	BIT4	Capacity
0	0	0	0	0
0	0	0	1	8 kW
0	0	1	0	10 kW
0	0	1	1	11.2 kW
0	1	0	0	12.5 kW
0	1	0	1	14 kW
0	1	1	0	16 kW
0	1	1	1	18 kW
1	0	0	0	20 kW
1	0	0	1	22.4 kW
1	0	1	0	25.2 kW
1	0	1	1	28.5 kW
1	1	0	0	33.5 kW
1	1	0	1	/
1	1	1	0	/
1	1	1	1	/

ODU Control Panel

Parameter setting:

MEU1	Set parameters		
	SP01	Set centralized control address	AR01, AR02.....AR99
	SP02	Set baud rate for centralized monitoring	1920Q 9600
	SP03	Silent mode	0: non-silent mode
			1: temperature trend control
			2: smart silent mode
			3: forced silent mode
	SP09	Manual power on/off	0003: cooling fully on, 0004: cooling fully off
			0009: heating fully on, 0010: heating fully off
	SP10	Manual address clearing	Choose 0033 and then K4
	SP11	Manual oil return	Choose 0015 and then K4
	SP12	Reserved	
MEU2	Display parameters		
	Choose KEY2/KEY3 to scroll up/down	System parameters	00-38
		Current fault code	E*** EC**
MEU3	Set features		
		Forced defrosting	Press and hold K1 for 5s and then release the button
		Open valve	Press and hold K4 for 5s and then release the button

KEY1: Click KEY1 menu key to cyclically display MEU1/MEU2/MEU3. Then click KEY4 to confirm your choice and enter the next level of menu.

KEY2/KEY3: After entering the second-level menu, click KEY2/KEY3 to scroll up and down, and click KEY4 to confirm to enter the next level of menu.

KEY4: confirm key

ODU Control Panel

Table of fault codes of digital tubes:

Fault Code	Content
E000	Disconnection of inverter high pressure switch
E001	Fan drive fault
E002	Inverter compressor overload
E003	Too high air discharge temperature
E004	Inverter drive communication fault
E005	Fan drive communication fault
E006	Inverter drive overheat fault
E007	Inverter drive fault
E008	THo1 sensor fault
E009	THo2 sensor fault
E010	THo3 sensor fault
E011	THo4 sensor fault
E012	THo5 sensor fault
E013	THo6 sensor fault
E014	THo7 sensor fault
E015	/
E016	/
E017	/
E018	/
E019	Fault 8032 (The unit generates an alarm without shutdown)
E020	IDU and ODU not matched
E021	Low pressure sensor fault
E022	High pressure sensor fault
E023	Phase sequence protection
E024	/
E025	/
E026	/
E027	/
E028	/
E029	/
E030	/
E031	/
E032	4-way valve fault (insufficient pressure difference)
E033	/
E034	Insufficient refrigerant
E035	/
E036	/

ODU Control Panel

E037	Protection enabled when ambient temperature too high/low
E038	No communication
E039	System failure
E040	Protection against high AC voltage
E041	Protection against low AC voltage
E042	Protection against high AC current
E043	Disconnection of low pressure switch
E044	Heat exchanger high temperature protection
E045	Compressor reverse rotation fault
ECXX	IDU communication fault

ECXX indicates communication failure between IDU and ODU, and EC00 indicates IDU 0#, and EC01 indicates IDU 1#, and so on.



Follow the Official Site
of TICA PRO LLC
www.tica.ru

«TICA PRO» LLC

Tel.: +7 495 127 79 00, +7 969 190 85 85

E-mail: info@tica.pro

www.tica.ru
