

PRO
TICA



Commercial Air Conditioners 2023



Fan Coil Unit

Established in 1991

TICA is a professional enterprise specialized in R&D, manufacturing, sales and services of environment cleaning and thermal energy utilization.

Vision

Strive to be the international leading integrated system and service provider in clean environment and utilization of thermal energy

Mission

Persist to maximize the value for customers through innovative technology and provide clean environment in order to improve the quality of life

TICA is a national high-tech enterprise, a single leading enterprise cultivated by the Ministry of Industry and Information Technology, a national brand cultivation enterprise of the Ministry of Industry and Information Technology, and a vice chairman member of China Refrigeration and Air-conditioning Industry Association. It has a national-recognized enterprise technology center, an enterprise academician workstation, and a post-doctoral research workstation. Its projects cover Beijing Bird's Nest Stadium, Water Cube, Wukesong Indoor Stadium, PetroChina, Sinopec, State Grid, Nanjing Panda, Hangzhou Xiaoshan International Airport, Hainan Airlines Group, Shangri-La Hotel, Manila Ocean Park, Abu Dhabi Al Muneera, SM City in Philippines and Unilever, etc.

TICA is also the outstanding provider of central air conditioners for China's subway networks and has successfully served nearly 70 key subway lines in major cities such as Beijing, Shanghai, Guangzhou, Shenzhen, Chengdu, Suzhou, Hangzhou and Tianjin. TICA is a professional supplier and service provider in China that specializes in system integration of clean environment. While for microelectronics, hospital operating rooms, biopharmaceutical industry and other professional purification areas, each achieving a market share of over 40%.

TICA, Visible Cleanness
TICA, Visible Energy-Saving

Standard Duct -TCR

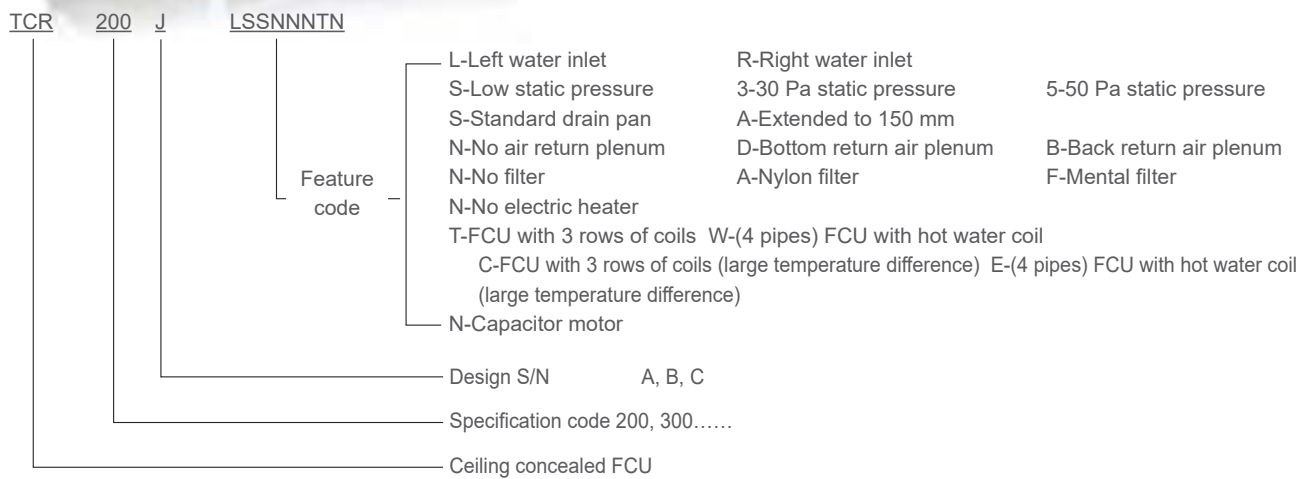

1. Different ESP for option

12Pa,30Pa,50Pa is standard,and 80Pa can be customized.

2. Multiple coils design

Two-pipe system (3 rows) and four-pipe system (3+1) are available.

3. Return air purifiers as optional to make environment clean

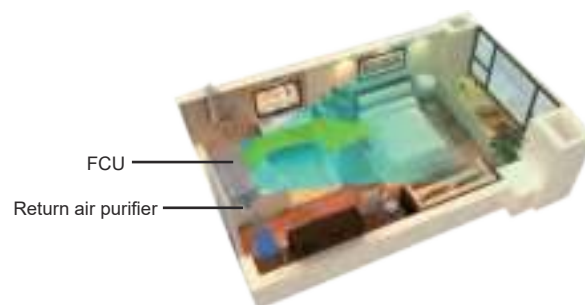
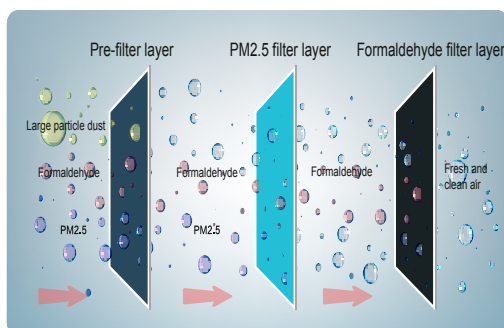

Operating principles:

The pre-filter layer removes hair, dust, and large particles from the air; the professional PM2.5 filter layer adopts the unique electrostatic technology to remove PM2.5 from the air through physical adsorption measures, without causing ozone hazard; the capture agent on the formaldehyde filter surface shows a formaldehyde removal capacity more powerful than that of the traditional activated carbon net, and converts the formaldehyde in air into a kind of safe and harmless substance through chemical reaction, instead of releasing it into the room with air and without leading to secondary pollution because of filtration adsorption and heating.

Standard Duct (3 Rows)

Model: TCR		200J	300J	400J	500J	600J	700J	800J	1000J	1200J	1400J	
Rated Air Flow (m ³ /h)	High	340	510	680	850	1020	1190	1360	1700	2040	2380	
	Medium	270	380	510	640	780	880	1030	1290	1540	1850	
	Low	190	280	340	450	560	610	740	890	1040	1255	
Cooling Capacity (W)	High	2210	3200	4150	5000	5950	6600	8100	9100	11250	13000	
	Medium	1990	2782	3570	4197	5200	5600	6882	8200	9613	11700	
	Low	1635	2304	2950	3298	4200	4600	5749	6700	7403	7560	
Sensible Cooling Capacity (W)	High	1590	2285	2880	3570	4200	4700	5880	6700	8260	9750	
	Medium	1400	1920	2420	2930	3570	3900	4880	5700	6935	8280	
	Low	1050	1555	1930	2210	2900	3200	3935	4500	5120	5945	
Heating Capacity (Water Inlet: 60°C) (W)		High	3500	5200	6500	7870	9800	10900	13570	14900	22100	
Heating Capacity (Water Inlet: 45°C) (W)		High	2210	3200	4150	5000	5950	6600	8100	9100	11250	
Power Input (W)	12Pa	High	30	45	55	72	93	100	128	147	183	221
		Medium	27	36	43	58	80	97	112	130	165	198
		Low	23	30	35	48	68	78	95	110	136	165
	30 Pa	High	38	55	65	82	100	120	148	169	206	245
		Medium	32	45	50	64	80	105	133	160	195	230
		Low	27	33	37	53	70	90	128	140	170	195
	50 Pa	High	45	64	75	91	114	130	165	200	243	290
		Medium	36	50	65	86	105	110	150	190	230	270
		Low	30	42	55	73	90	96	122	170	200	250
Sound Level (dB(A))	Low Static Pressure (12Pa)	High	35	38	39	41	45	46	46	47	49	51
		Medium	28.5	30	31	32	37	40	40	41	44	47
		Low	20.5	21	22	24	28	31	31	32	34	35
	30 Pa	High	38	41	42.5	45	46.5	48	47	49	51	52
		Medium	30.5	32	34	36.5	38.5	41	41	43	46	48
		Low	23	22	22	27.5	30	32	32	34	35	36
	50 Pa	High	42	43	45	47	49	50	50	52	53	53
		Medium	35.5	36	38	38.5	40	44	44	46	47.5	49
		Low	29	28	28	29	31	36	36	38	40	42
Fan	Type	Forward-curved multi-blade double inlet centrifugal fan										
Motor	Type	Single-phase capacitor motor										
Heat Exchanger	Structure Type	Efficient double-flanged aluminum fins and copper tubes, expanded into one										
	Maximum Operating Pressure (MPa)	1.6										
	Water Inlet/Outlet Pipe Diameter (inch)	Rc3/4 (Taper Pipe Female Threaded)										
	Water Flow (m ³ /h)	0.42	0.55	0.72	0.87	1.05	1.12	1.39	1.67	1.9	2.23	
Water Resistance	kPa	25	25	30	30	40	40	40	40	40	50	
Drain Pan	Condensate Water Pipe Diameter (inch)	Rc3/4 (Taper Pipe Male Threaded)										
Dimensions (Without Return Air Plenum)	Length (mm)	695	845	930	995	1085	1235	1530	1530	1795	1795	
	Width (mm)	470	470	470	470	470	470	470	470	490	490	
	Height (mm)	230	230	230	230	230	230	230	230	250	250	
Net Weight	Air Return Plenum (Excluded) (kg)	10.5	12.5	14.5	16	17	18.5	22	25	30	31.5	
	Air Return Plenum (Included) (kg)	12.5	15.5	17.5	19	20	22.5	26	29	36	37.5	

★ Note:

- Cooling: supply water and return water temperatures 7/12°C; the dry/wet bulb temperature of air inlet is 27/19.5°C;
- Heating: supply water is 60°C or 45°C, water quantity being the same as during cooling; air return conditions: the dry bulb temperature of air inlet is 21°C;
- In the table, low static pressure indicates the air outlet static pressure at 0Pa (with air outlet and filter) and at 12Pa (without air outlet and filter);
- The air flow in the table is obtained when the unit is running in dry state and the dry bulb temperature of air inlet is 20°C;
- Left & right swing manner can be adjusted on site. After adjustment, the cooling capacity and heating capacity should be multiplied by the correction factor 0.9;

Standard Duct (3+1 Rows)

Model: TCR		200J	300J	400J	500J	600J	700J	800J	1000J	1200J	1400J	
Rated Air Flow (m ³ /h)	High	340	500	680	830	1000	1140	1340	1700	2040	2380	
	Medium	270	380	510	620	750	880	1030	1290	1540	1975	
	Low	190	240	340	420	560	610	720	890	1040	1255	
Cooling Capacity (W)	High	2210	3200	4150	4800	5950	6800	7900	9200	10275	12600	
	Medium	1890	2782	3570	4150	5200	5900	6900	8000	8500	11000	
	Low	1500	2304	2950	3400	4200	5000	5800	6700	7450	9500	
Sensible Cooling Capacity (W)	High	1590	2285	2880	3400	4200	4700	5750	6600	7400	9400	
	Medium	1350	1920	2420	2880	3570	3900	4800	5500	6200	7900	
	Low	1050	1555	1930	2210	2900	3200	3700	4200	4930	6200	
Heating Capacity (60/50°C) (W)	High	2050	3000	3850	4500	5200	6300	7550	8400	9800	10800	
Heating Capacity (45/40°C) (W)	High	1300	1800	2300	2700	3200	3700	4500	5100	6100	6600	
Power Input (W)	12Pa	High	30	45	55	72	93	100	128	147	183	221
		Medium	27	36	43	58	80	97	112	130	165	198
		Low	23	30	35	48	68	78	95	110	136	165
	30 Pa	High	38	55	65	82	100	120	148	169	206	245
		Medium	32	45	50	64	80	105	133	160	195	230
		Low	27	33	37	53	70	90	128	140	170	195
	50 Pa	High	45	64	75	91	114	130	165	200	243	290
		Medium	36	50	65	86	105	110	150	190	230	270
		Low	30	42	55	73	90	96	122	170	200	250
Sound Level (dB(A))	12Pa	High	36.5	38	39	42	45	46	46	47	49	51
		Medium	30	30	31	33	38	41	41	41	44	47
		Low	21	21	22	25	29	32	32	33	34	36
	30 Pa	High	38.5	41	42.5	45	46.5	48	47	49	51	52.5
		Medium	32	32.5	34	37.5	39	42	41	43	46	48
		Low	23	23	24	28.5	30	33	32	34	35.5	37
	50 Pa	High	42	43.5	45	47	49	50	50	52	53	53.5
		Medium	36	37	38	39.5	41	45	45	46.5	47.5	50
		Low	29	29	30	30	32	36	36	38	41	43
Fan	Type	Forward-curved multi-blade double inlet centrifugal fan										
Motor	Type	Single-phase capacitor motor										
Heat Exchanger	Structure Type	Efficient double-flanged aluminum fins and copper tubes, expanded into one										
	Maximum Operating Pressure (MPa)	1.6										
	Water Inlet/Outlet Pipe Diameter (inch)	Rc3/4 (Taper Pipe Female Threaded)										
Water Flow	Cooling Mode (m ³ /h)	0.39	0.63	0.73	0.86	1.04	1.17	1.39	1.65	1.9	2.04	
	Heating Mode (60/50°C) (m ³ /h)	0.21	0.29	0.33	0.42	0.47	0.55	0.66	0.72	0.88	0.95	
	Heating Mode (45/40°C) (m ³ /h)	0.22	0.31	0.41	0.47	0.53	0.63	0.76	0.86	1.04	1.13	
Water Resistance	Cooling Mode (kPa)	25	25	30	30	40	40	40	40	40	50	
	Heating Mode (60/50°C) (kPa)	10	10	20	25	15	20	30	20	30	35	
	Heating Mode (45/40°C) (kPa)	10	15	25	30	20	25	40	25	40	50	
Drain Pan	Condensate Water Pipe Diameter (inch)	Rc3/4 (Taper Pipe Male Threaded)										
Dimensions (Without Return Air Plenum)	Length (mm)	695	845	930	995	1085	1235	1530	1530	1795	1795	
	Width (mm)	470	470	470	470	470	470	470	470	490	490	
	Height (mm)	230	230	230	230	230	230	230	230	250	250	
Net weight	Air Return Plenum (Excluded) (kg)	11.5	13.5	15.5	17	19	20	24	27	33	35	
	Air Return Plenum (Included) (kg)	13.5	16.5	18.5	20	22	24	28	31	39	41	

★ Note:

1. Cooling: supply water and return water temperatures 7/12°C; the dry/wet bulb temperature of air inlet is 27/19.5°C;
2. Heating: supply water is 60°C or 45°C, water quantity being the same as during cooling; air return conditions: the dry bulb temperature of air inlet is 21°C;
3. In the table, low static pressure indicates the air outlet static pressure at 0Pa (with air outlet and filter) and at 12Pa (without air outlet and filter);
4. The air flow in the table is obtained when the unit is running in dry state and the dry bulb temperature of air inlet is 20°C;
5. Left & right swing manner can be adjusted on site. After adjustment, the cooling capacity and heating capacity should be multiplied by the correction factor 0.9;

Standard Duct (Large Temperature Difference, 3 Rows)

Model: TCR		200J	300J	400J	500J	600J	700J	800J	1000J	1200J	1400J	
Rated Air Flow (m³/h)	High	340	510	680	850	1020	1190	1360	1700	2040	2380	
	Medium	270	380	510	640	780	880	1030	1290	1540	1850	
	Low	190	280	340	450	560	610	740	890	1040	1255	
Cooling Capacity (W)	High	2200	3100	4000	4800	5750	6500	8000	9100	11250	12800	
	Medium	1900	2700	3500	4100	5000	5500	6800	8200	9600	11000	
	Low	1600	2250	2900	3200	4000	4500	5700	6700	7400	7500	
Sensible Cooling Capacity (W)	High	1500	2200	2800	3500	4100	4700	5800	6700	8200	9700	
	Medium	1400	1900	2400	2900	3500	3900	4800	5700	6900	8200	
	Low	1050	1500	1900	2200	2800	3200	3900	4500	5100	5900	
Heating Capacity (60/50°C) (W)	High	3400	4850	6100	7500	9000	10200	12300	14500	17500	19900	
Heating Capacity (45/40°C) (W)	High	2100	3000	3850	4600	5500	6300	7700	8800	10800	12300	
Power Input (W)	12Pa	High	30	45	55	72	93	100	128	147	183	221
		Medium	27	36	43	58	80	97	112	130	165	198
		Low	23	30	35	48	68	78	95	110	136	165
	30 Pa	High	38	55	65	82	100	120	148	169	206	245
		Medium	32	45	50	64	80	105	133	160	195	230
		Low	27	33	37	53	70	90	128	140	170	195
	50 Pa	High	45	64	75	91	114	130	165	200	243	290
		Medium	36	50	65	86	105	110	150	190	230	270
		Low	30	42	55	73	90	96	122	170	200	250
Sound Level (dB(A))	12Pa	High	35	38	39	41	45	46	46	47	49	51
		Medium	28.5	30	31	32	37	40	40	41	44	47
		Low	20.5	21	22	24	28	31	31	32	34	35
	30 Pa	High	38	41	42.5	45	46.5	48	47	49	51	52
		Medium	30.5	32	34	36.5	38.5	41	41	43	46	48
		Low	23	22	22	27.5	30	32	32	34	35	36
	50 Pa	High	42	43	45	47	49	50	50	52	53	53
		Medium	35.5	36	38	38.5	40	44	44	46	47.5	49
		Low	29	28	28	29	31	36	36	38	40	42
Fan	Type	Forward-curved multi-blade double inlet centrifugal fan										
Motor	Type	Single-phase capacitor motor										
Heat Exchanger	Maximum Operating Pressure (MPa)	Efficient double-flanged aluminum fins and copper tubes, expanded into one										
	Water Inlet/Outlet Pipe Diameter	1.6										
	Water Inlet/Outlet Pipe Diameter (inch)	Rc3/4 (Taper Pipe Female Threaded)										
	Water Flow m³/h	0.24	0.33	0.45	0.5	0.61	0.7	0.83	0.99	1.2	1.42	
Water Resistance	kPa	25	25	30	25	40	30	30	40	40	40	
Drain Pan	Condensate Water Pipe Diameter (inch)	Rc3/4 (Taper Pipe Male Threaded)										
Dimensions (Without Return Air Plenum)	Length (mm)	695	845	930	995	1085	1235	1530	1530	1795	1795	
	Width (mm)	470	470	470	470	470	470	470	470	490	490	
	Height (mm)	230	230	230	230	230	230	230	230	250	250	
Net weight	Air Return Plenum (Excluded) (kg)	10.5	12.5	14.5	16	17	18.5	22	25	30	31.5	
	Air Return Plenum (Included) (kg)	12.5	15.5	17.5	19	20	22.5	26	29	36	37.5	

★ Note:

- Cooling: supply water and return water temperatures 5/13°C; the dry/wet bulb temperature of air inlet is 27/19.5°C;
- Heating: supply water is 60°C or 45°C, water quantity being the same as during cooling; air return conditions: the dry bulb temperature of air inlet is 21°C;
- In the table, low static pressure indicates the air outlet static pressure at 0Pa (with air outlet and filter) and at 12Pa (without air outlet and filter);
- The air flow in the table is obtained when the unit is running in dry state and the dry bulb temperature of air inlet is 20°C;
- Left & right swing manner can be adjusted on site. After adjustment, the cooling capacity and heating capacity should be multiplied by the correction factor 0.9;

Standard Duct (Large Temperature Difference, 3+1 Rows)

Model: TCR		200J	300J	400J	500J	600J	700J	800J	1000J	1200J	1400J	
Rated Air Flow (m ³ /h)	High	340	500	680	830	1000	1140	1340	1700	2040	2380	
	Medium	270	380	510	620	750	880	1030	1290	1540	1975	
	Low	190	240	340	420	560	610	720	890	1040	1255	
Cooling Capacity (W)	High	2200	3100	4000	4800	5750	6500	8000	9100	11250	12800	
	Medium	1900	2700	3500	4100	5000	5500	6800	8200	9600	11000	
	Low	1600	2250	2900	3200	4000	4500	5700	6700	7400	7500	
Sensible Cooling Capacity (W)	High	1500	2200	2800	3500	4100	4700	5800	6700	8200	9700	
	Medium	1400	1900	2400	2900	3500	3900	4800	5700	6900	8200	
	Low	1050	1500	1900	2200	2800	3200	3900	4500	5100	5900	
Heating Capacity (60/50°C) (W)		High	2050	3000	3850	4500	5200	6300	7550	8400	10800	
Heating Capacity (45/40°C) (W)		High	1300	1800	2300	2700	3200	3700	4500	5100	6600	
Power Input (W)	12Pa	High	30	45	55	72	93	100	128	147	183	221
		Medium	27	36	43	58	80	97	112	130	165	198
		Low	23	30	35	48	68	78	95	110	136	165
	30 Pa	High	38	55	65	82	100	120	148	169	206	245
		Medium	32	45	50	64	80	105	133	160	195	230
		Low	27	33	37	53	70	90	128	140	170	195
	50 Pa	High	45	64	75	91	114	130	165	200	243	290
		Medium	36	50	65	86	105	110	150	190	230	270
		Low	30	42	55	73	90	96	122	170	200	250
Sound Level (dB(A))	12Pa	High	36.5	38	39	42	45	46	46	47	49	51
		Medium	30	30	31	33	38	41	41	41	44	47
		Low	21	21	22	25	29	32	32	33	34	36
	30 Pa	High	38.5	41	42.5	45	46.5	48	47	49	51	52.5
		Medium	32	32.5	34	37.5	39	42	41	43	46	48
		Low	23	23	24	28.5	30	33	32	34	35.5	37
	50 Pa	High	42	43.5	45	47	49	50	50	52	53	53.5
		Medium	36	37	38	39.5	41	45	45	46.5	47.5	50
		Low	29	29	30	30	32	36	36	38	41	43
Fan	Type	Forward-curved multi-blade double inlet centrifugal fan										
Motor	Type	Single-phase capacitor motor										
Heat Exchanger	Structure Type	Efficient double-flanged aluminum fins and copper tubes, expanded into one										
	Maximum Operating Pressure (MPa)	1.6										
	Water Inlet/Outlet Pipe Diameter (inch)	Rc3/4 (Taper Pipe Female Threaded)										
Water Flow	Cooling Mode (m ³ /h)	0.24	0.33	0.45	0.5	0.61	0.7	0.83	0.99	1.2	1.42	
	Heating Mode (60/50°C) (m ³ /h)	0.21	0.29	0.33	0.42	0.47	0.55	0.66	0.72	0.88	0.95	
	Heating Mode (45/40°C) (m ³ /h)	0.22	0.31	0.41	0.47	0.53	0.63	0.76	0.86	1.04	1.13	
Water Resistance	Cooling Mode (kPa)	25	25	30	25	40	30	30	40	40	40	
	Heating Mode (60/50°C) (kPa)	10	10	20	25	15	20	30	20	30	35	
	Heating Mode (45/40°C) (kPa)	10	15	25	30	20	25	40	25	40	50	
Drain Pan	Condensate Water Pipe Diameter (inch)	Rc3/4 (Taper Pipe Male Threaded)										
Dimensions (Without Return Air Plenum)	Length (mm)	695	845	930	995	1085	1235	1530	1530	1795	1795	
	Width (mm)	470	470	470	470	470	470	470	470	490	490	
	Height (mm)	230	230	230	230	230	230	230	230	250	250	
Net Weight	Air Return Plenum (Excluded) (kg)	11.5	13.5	15.5	17	19	20	24	27	33	35	
	Air Return Plenum (Included) (kg)	13.5	16.5	18.5	20	22	24	28	31	39	41	

★ Note:

1. Cooling: supply water and return water temperatures 5/13°C; the dry/wet bulb temperature of air inlet is 27/19.5°C;
2. Heating: supply water and return water temperatures 60/50°C or 45/40°C; air return conditions: the dry bulb temperature of air inlet is 21°C;
3. In the table, low static pressure indicates the air outlet static pressure at 0Pa (with air outlet and filter) and at 12Pa (without air outlet and filter);
4. The air flow in the table is obtained when the unit is running in dry state and the dry bulb temperature of air inlet is 20°C;
5. For a 4-pipe unit, there are 3 rows of cooling coils and 1 row of heating coil;

Dimension

Standard Duct (3 Rows/Large Temperature Difference, 3 Rows)

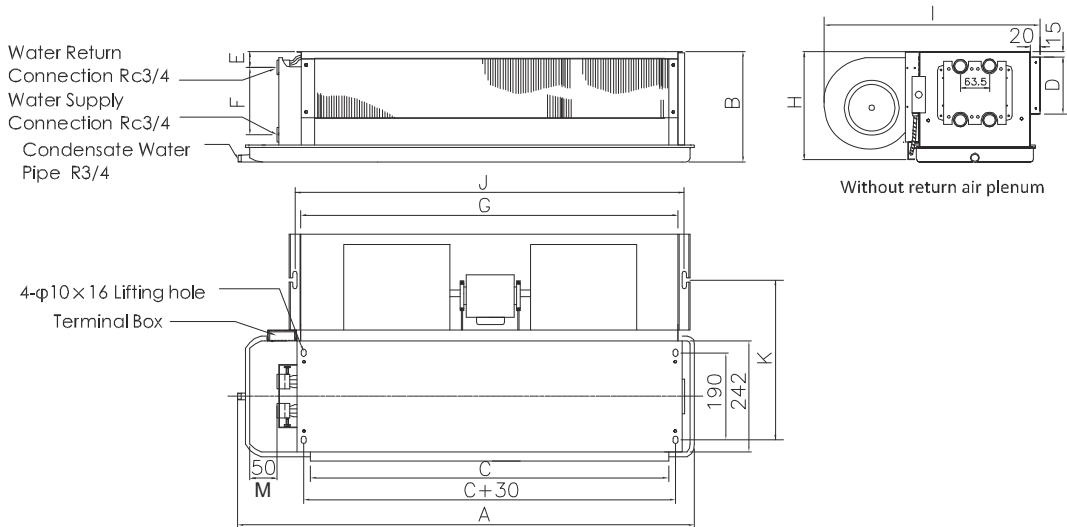

TCR	A	B	C	D	E	F	G	H	I	J	K	M	Motor Quantity	Fan Quantity
200	695	230	435	135	54	118	477	225	470	504	346	50	1	1
300	845	230	570	135	54	118	610	225	470	637	346	65	1	2
400	930	230	670	135	54	118	712	225	470	739	346	50	1	2
500	995	230	730	135	54	118	772	225	470	799	346	55	1	2
600	1085	230	825	135	54	118	867	225	470	894	346	50	1	2
700	1235	230	970	135	54	118	1012	225	470	1039	346	55	1	2
800	1530	230	1215	135	54	118	1257	225	470	1284	346	105	1	3
1000	1530	230	1255	135	54	118	1297	225	470	1324	346	65	2	3
1200	1795	250	1510	135	54	118	1552	240	490	1579	357	45	2	4
1400	1795	250	1510	135	54	118	1552	240	490	1579	357	45	2	4

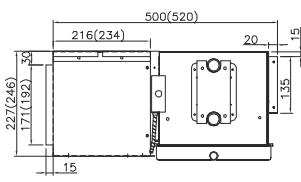

With back return air plenum (TCR200-1200)
 Dimensions in brackets for TCR1200

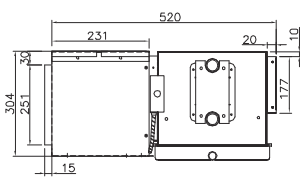

With back return air plenum (TCR1400)

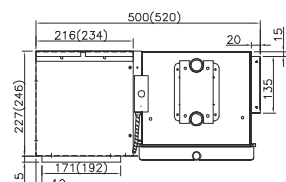

With bottom return air plenum (TCR200-1200)
 Dimensions in brackets for TCR1200

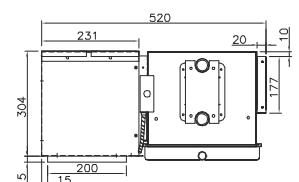

With bottom return air plenum (TCR1400)

TCR	Length of return air plenum	Length of plenum wind-gap
200	483.6	422
300	615.6	557
400	725.6	657
500	775.6	717
600	870.6	812
700	1015.6	957
800	1260.6	1202
1000	1300.6	1242
1200	1555.6	1497
1400	1634	1596

Standard Duct (3+1 Rows//Large Temperature Difference, 3+1 Rows)

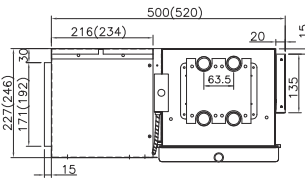
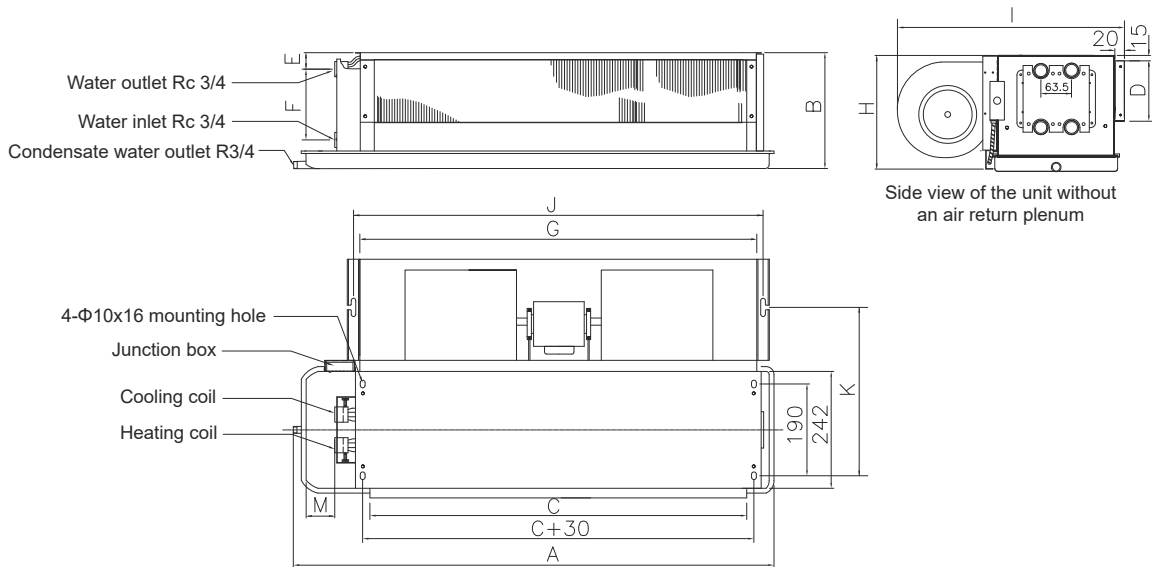

Side view of the unit with a rear air return plenum (models 200-1200)
Side view of the unit with a rear air return plenum (model 1400)

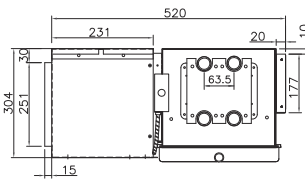

Side view of the unit with a rear air return plenum (models 1400)

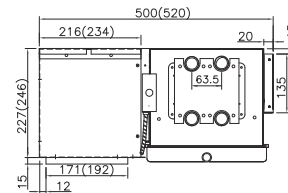

Side view of the unit with a bottom air return plenum (models 200-1200) (Dimensions in brackets are dimensions of model 1200)

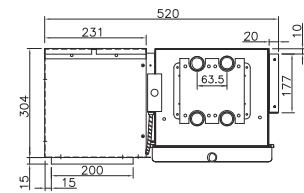

Side view of the unit with a bottom air return plenum (model 1400)

Model: TCR	A	B	C	D	E	F	G	H	I	J	K	M
200	695	230	435	135	54	118	477	225	470	504	346	50
300	845	230	570	135	54	118	610	225	470	637	346	65
400	930	230	670	135	54	118	712	225	470	739	346	50
500	995	230	730	135	54	118	772	225	470	799	346	55
600	1085	230	825	135	54	118	867	225	470	894	346	50
700	1235	230	970	135	54	118	1012	225	470	1039	346	55
800	1530	230	1215	135	54	118	1257	225	470	1284	346	105
1000	1530	230	1255	135	54	118	1297	225	470	1324	346	65
1200	1795	250	1510	135	54	118	1552	240	490	1579	357	45
1400	1795	250	1510	135	54	118	1552	240	490	1579	357	45

★ Note:

1. The air return plenum unit with a filter screen does not have an air return flange only, with other dimensions remaining the same.
2. When vibration-absorbing lifting hooks are used for lifting the unit, tell the factory about it.

DC Brushless FCU-TCR-R

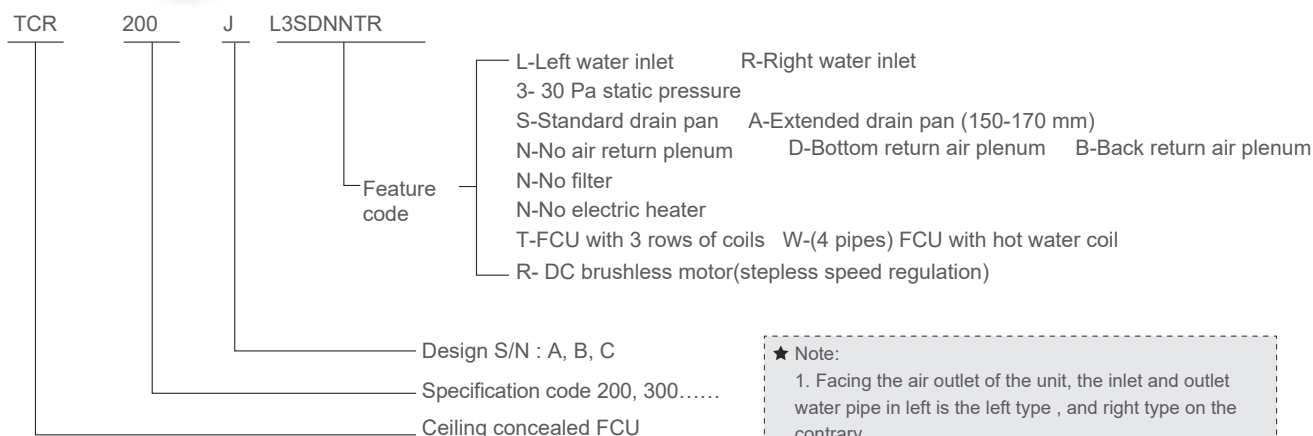

★ Note:

1. Facing the air outlet of the unit, the inlet and outlet water pipe in left is the left type , and right type on the contrary
2. 30Pa is standard,and 12Pa、 50Pa can be adjusted on site.

1. Compact, Light, Flexible and Elegant

The product is compact in structure, with depth as low as 470 mm and thickness as low as 230 mm. It is especially suitable for restricted ceiling space and can save building floor height.

2. Highly Efficient and Eco-Friendly

Highly efficient brushless DC motor is used with low wind resistance energy-saving heat exchanger to achieve higher efficiency. During operation, the energy consumption can be greatly saved during low load period through stepless regulation of speed.

3. Low Noise, Exceptional Comfort

The motor features UHF drive emitting only very low noise, and the fan adopts large impeller achieving low speed. Selected noise insulation materials are used with unique intelligent mute control logic, so that the operating noise can be as low as 20 dB (A).

4. Safe and Reliable Drainage Pan

The pan is formed using one-off processing technology without any welds and processed with anti-corrosion treatment; The thermal insulation material at the bottom has no joint and no condensation problem. The fire protection rating is non-flammable, so it is safe to use.

5. Simple Electronic Control Configuration

Easy to operate, four-speed flexible wind control (high, medium, low, mute), and intelligent stepless regulation in auto-speed mode.

6. Convenient Installation

The product can be selected as left type or right type, and the type can be adjusted at the installation site; The air return type can be selected as back return or bottom return, and the air return direction can be switched at the installation site.

7. Various External Static Pressures

The user can quickly convert among external static pressures 12Pa, 30Pa and 50Pa through a DIP switch at the installation site to meet different applications.

8. Network Intelligent Temperature Control

Equipped with RS485 interface, and supporting Modbus communication protocol, this air conditioner can be connected to automatic control system of the building for centralized management to realize functions such as remote power on/off, mode setting, and operation monitoring for convenient operation management and energy saving.

- Black or white optional
- Electric valve and fan controllable
- Temperature sensor built-in to display the indoor temperature
- Both 2-pipe and 4-pipe models applicable
- Embedded functions such as child lock, power-off memory, anti-freeze protection, and sleep mode.



2-pipes (3 Rows)

Model: TCR			200J	300J	400J	500J	600J	800J	1000J	1200J	1400J
Rated Air Flow (m ³ /h)	High		340	510	680	850	1020	1360	1700	2040	2380
	Medium		270	380	510	640	780	1030	1290	1540	1850
	Low		190	280	340	450	560	740	890	1040	1255
	Silence		135	205	270	340	410	545	680	815	950
Cooling Capacity (W)	High		2210	3200	4150	5000	5950	8100	9100	11250	13000
	Medium		1990	2782	3570	4197	5200	6882	8200	9613	11700
	Low		1635	2304	2950	3298	4200	5749	6700	7403	7560
	Silence		1005	1460	2000	2340	2900	3940	4600	5630	6785
Sensible Cooling Capacity (W)	High		1590	2285	2880	3570	4200	5880	6700	8260	9750
	Medium		1400	1920	2420	2930	3570	4880	5700	6935	8280
	Low		1050	1555	1930	2210	2900	3935	4500	5120	5945
	Silence		680	1005	1350	1620	1980	2680	3200	3875	4615
Heating Capacity (Water Inlet: 60°C) (W)		High	3500	5200	6500	7870	9800	13000	14900	18800	22100
Heating Capacity (Water Inlet: 45°C) (W)		High	2210	3200	4150	5000	5950	8100	9100	11250	13000
Power Input (W)	Low static pressure 12 Pa	High/Medium/Low/Silence	14/9/7/6	18/11/7/6	24/14/9/7	36/21/12/7	52/31/17/8	61/35/19/10	82/41/29/15	102/48/34/16	120/75/34/17
	static pressure 30 Pa	High/Medium/Low/Silence	20/13/8/6	25/15/9/7	33/17/11/7	48/28/15/8	65/38/19/9	80/45/22/11	99/49/33/16	124/56/38/17	146/90/39/19
	static pressure 50 Pa	High/Medium/Low/Silence	26/16/10/7	33/19/10/8	45/22/14/8	61/36/18/9	80/46/22/10	99/46/26/13	118/59/37/18	152/69/45/19	175/106/45/21
FCEER	Low static pressure 12 Pa	High	123	135	120	109	88	99	85	86	80
	static pressure 30 Pa	High	92	104	95	86	73	80	73	73	69
	static pressure 50 Pa	High	74	82	73	70	62	64	63	62	60
FCCOP(Water Inlet: 60°C)	Low static pressure 12 Pa	High	195	225	203	172	145	159	140	144	137
	static pressure 30 Pa	High	146	173	158	136	122	129	120	124	118
	static pressure 50 Pa	High	117	137	122	111	103	108	104	104	102
FCCOP(Water Inlet: 45°C)	Low static pressure 12 Pa	High	123	135	120	109	88	99	85	86	80
	static pressure 30 Pa	High	92	104	95	86	73	80	73	73	69
	static pressure 50 Pa	High	74	82	73	70	62	64	63	62	60
Sound Level (dB(A))	Low Static Pressure (12 Pa)	High/Medium/Low/Silence	33/26/23/19	35/28/25/20	39/29/25/20	40.5/34/29/21	43/35/31/21	44/39/31/27	46/41/34/23	47/41/33.5/24	48/43/37/26
	static pressure 30 Pa	High/Medium/Low/Silence	34/30/24/20	37/31/27/20	39/32/27/20	40.5/37/30/21	42/37/32/22	44/38/33/25	46/42.5/36/28	47/41/35/28	48/43/36/25
	static pressure 50 Pa	High/Medium/Low/Silence	38/33/27/22	40/35/30/23	42/35/32/23	43.5/37/33/23	44.5/37/33/23	46/40/35/25	48/44/37/28	49/44/37/28	49/44/37/26
Fan	Type	Forward-curved multi-blade double inlet centrifugal fan									
Motor	Type	DC brushless motor(built in conversion)									
Heat Exchanger	Structure Type	Efficient double-flanged aluminum fins and copper tubes, expanded into one									
	Maximum Operating Pressure (MPa)	1.6									
	Water Inlet/Outlet Pipe Diameter (inch)	Rc3/4 (Taper Pipe Female Threaded)									
	Water Flow (m ³ /h)	0.42	0.55	0.72	0.87	1.05	1.39	1.67	1.9	2.23	
Water Resistance	kPa	25	25	30	30	40	40	40	40	50	
Drain Pan	Condensate Water Pipe Diameter (inch)	R3/4 (Taper Pipe Male Threaded)									
Dimensions (Without Return Air Plenum)	Length (mm)	695	845	930	995	1085	1490	1530	1795	1795	
	Width (mm)	470	470	470	470	470	470	470	490	490	
	Height (mm)	230	230	230	230	230	230	230	250	292	

★ Note:

1. Cooling: supply water and return water temperatures 7/12°C; the dry/wet bulb temperature of air inlet is 27/19.5°C;
2. Heating: supply water is 60°C or 45°C, water quantity being the same as during cooling; air return conditions: the dry bulb temperature of air inlet is 21°C;
3. In the table, low static pressure indicates the air outlet static pressure at 0Pa (with air outlet and filter) and at 12Pa (without air outlet and filter);
4. The air flow in the table is obtained when the unit is running in dry state and the dry bulb temperature of air inlet is 20°C;
5. The noise in the table is measured in a semi-anechoic chamber with background noise of 11.5dB(A).
6. Left & right swing manner can be adjusted on site. After adjustment, the cooling capacity and heating capacity should be multiplied by the correction factor 0.9;
7. Specifications are subject to change without notice due to product improvement, please refer to the nameplate of the unit.

4-pipes (3 +1Rows)

Model: TCR			200J	300J	400J	500J	600J	800J	1000J	1200J	1400J
Rated Air Flow (m ³ /h)	High		340	510	640	830	1000	1340	1650	2040	2350
	Medium		270	380	510	620	750	1030	1290	1540	1850
	Low		190	280	410	450	560	720	890	1040	1255
	Silence		135	205	280	340	410	545	680	815	950
Cooling Capacity (W)	High		2210	3200	4150	4800	5950	7900	9200	10275	12600
	Medium		1890	2782	3570	4150	5200	6900	8000	8500	11000
	Low		1500	2304	2950	3400	4200	5800	6700	7450	9500
	Silence		1005	1460	2000	2340	2900	3940	4600	5630	6785
Sensible Cooling Capacity (W)	High		1590	2285	2880	3400	4200	5750	6600	7400	9400
	Medium		1350	1920	2420	2880	3570	4800	5500	6200	7900
	Low		1050	1555	1930	2210	2900	3700	4200	4930	6200
	Silence		680	1005	1350	1620	1980	2680	3200	3875	4615
Heating Capacity (W)		High	2050	3000	3850	4500	5200	7550	8400	9800	10800
Power Input (W)	Low static pressure 12 Pa	High/Medium/Low/ Silence	14/10/8/6	18/12/8/6	24/14/9/7	36/22/12/7	54/31/17/8	63/39/21/10	84/41/29/15	104/48/34/16	125/75/35/17
	static pressure 30 Pa	High/Medium/Low/ Silence	20/13/9/6	25/15/9/7	34/18/11/7	48/28/15/8	65/40/20/9	83/45/25/12	101/49/33/16	127/56/38/17	151/90/39/19
	static pressure 50 Pa	High/Medium/Low/ Silence	27/16/10/7	34/19/10/8	46/22/14/8	62/36/18/9	80/48/23/10	101/47/28/13	123/59/38/18	155/69/45/19	178/106/45/21
FCEER	Low static pressure 12 Pa	High	125	134	121	105	85	94	84	77	75
	static pressure 30 Pa	High	93	103	92	83	73	76	73	66	65
	static pressure 50 Pa	High	72	80	72	67	62	64	62	56	57
FCCOP	Low static pressure 12 Pa	High	132	149	136	107	87	102	85	86	74
	static pressure 30 Pa	High	93	109	99	82	73	79	72	7,	62
	static pressure 50 Pa	High	70	81	73	65	59	66	60	58	54
Sound Level (dB(A))	Low static pressure 12 Pa	High/Medium/Low/ Silence	33/28/24/21	36/31/26/23	39/31/26/23	40.5/34/29/24	43/35/31/25	44/39/32/27	46/41/34/25	47/41/35/25	49/44/38/26
	static pressure 30 Pa	High/Medium/Low/ Silence	35/30/25/20	38/34/27/23	39/33/28/23	40.5/37/30/24	42/38/32/25	45/38/34/26	46/43/36/28	47/42/36/28	48/43/36/26
	static pressure 50 Pa	High/Medium/Low/ Silence	39/33/28/23	41/36/30/24	43/36/32/24	43.5/37/33/25	44.5/40/34/25	46/40/35/27	48/44/37/28	49/44/37/28	49/44/38/27
Fan	Type	Forward-curved multi-blade double inlet centrifugal fan									
Motor	Type	DC brushless motor(built in conversion)									
Heat Exchanger	Structure Type	Efficient double-flanged aluminum fins and copper tubes, expanded into one									
	Maximum Operating Pressure (MPa)	1.6									
	Water Inlet/Outlet Pipe Diameter (inch)	Rc3/4 (Taper Pipe Female Threaded)									
Water Flow	Cooling Mode (m ³ /h)	0.39	0.63	0.73	0.86	1.04	1.39	1.65	1.9	2.23	
	Heating Mode (m ³ /h)	0.21	0.29	0.33	0.42	0.47	0.66	0.72	0.88	0.95	
Water Resistance	Cooling Mode (kPa)	25	25	30	30	40	40	40	40	50	
	Heating Mode (kPa)	10	10	20	25	15	30	20	30	35	
Drain Pan	Condensate Water Pipe Diameter (inch)	R3/4 (Taper Pipe Male Threaded)									
Dimensions (Without Return Air Plenum)	Length (mm)	695	845	930	995	1085	1490	1530	1795	1795	
	Width (mm)	470	470	470	470	470	470	470	490	490	
	Height (mm)	230	230	230	230	230	230	230	250	292	

★ Note:

- Cooling: supply water and return water temperatures 7/12°C; the dry/wet bulb temperature of air inlet is 27/19.5°C;
- Heating: supply water is 60°C or 50°C; air return conditions: the dry bulb temperature of air inlet is 21°C;
- In the table, low static pressure indicates the air outlet static pressure at 0Pa (with air outlet and filter) and at 12Pa (without air outlet and filter);
- The air flow in the table is obtained when the unit is running in dry state and the dry bulb temperature of air inlet is 20°C;
- The noise in the table is measured in a semi-anechoic chamber with background noise of 11.5dB(A).
- 4-pipes units, 3 rows are cooling coil, and 1 row is heating coil.
- Specifications are subject to change without notice due to product improvement, please refer to the nameplate of the unit.

Dimension

Dimensions- 2-pipes(3 rows)

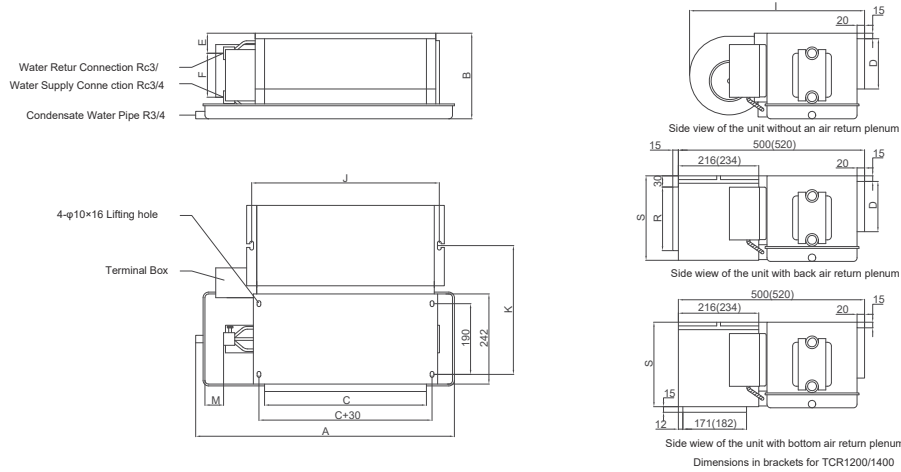

TCR	A	B	C	D	E	F	I	J	K	M	R	S	Length of air return plenum	Length of air return inlet
200	695	230	435	135	54	118	470	504	346	50	171	227	483.6	422
300	845	230	570	135	54	118	470	637	346	65	171	227	615.6	557
400	930	230	670	135	54	118	470	739	346	50	171	227	725.6	657
500	995	230	730	135	54	118	470	799	346	55	171	227	775.6	717
600	1085	230	825	135	54	118	470	894	346	50	171	227	870.6	812
800	1490	230	1215	135	54	118	470	1284	346	65	171	227	1260.6	1202
1000	1530	230	1255	135	54	118	470	1324	346	65	171	227	1300.6	1242
1200	1795	250	1510	135	54	118	490	1579	357	45	192	246	1555.6	1497
1400	1795	292	1510	177	41	171	490	1579	357	45	234	288	1555.6	1497

★ Note:

1. Diagram of unit with air return plenum, and the air return plenum has no filter
2. The air return plenum with filter has no air return flange
3. If shock absorption hook is used, special instructions should be given to the factory

Dimensions- 4-pipes(3+1 rows)

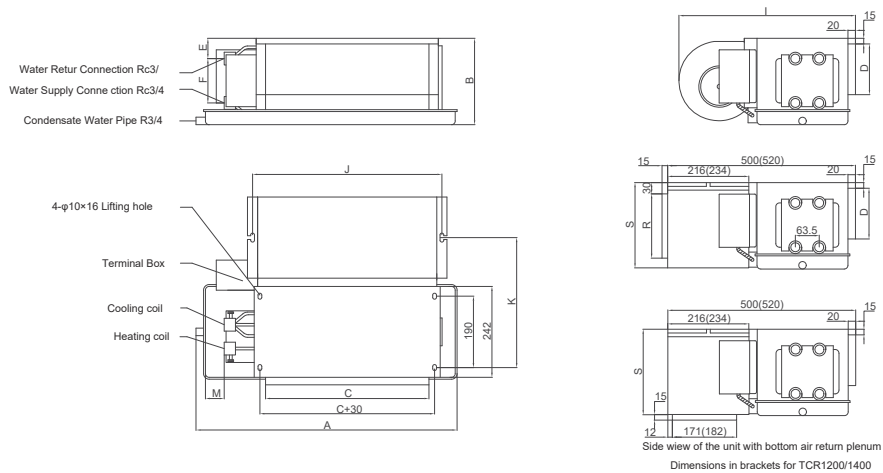

TCR	A	B	C	D	E	F	I	J	K	M	R	S	Length of air return plenum	Length of air return inlet
200	695	230	435	135	54	118	470	504	346	50	171	227	483.6	422
300	845	230	570	135	54	118	470	637	346	65	171	227	615.6	557
400	930	230	670	135	54	118	470	739	346	50	171	227	725.6	657
500	995	230	730	135	54	118	470	799	346	55	171	227	775.6	717
600	1085	230	825	135	54	118	470	894	346	50	171	227	870.6	812
800	1490	230	1215	135	54	118	470	1284	346	65	171	227	1260.6	1202
1000	1530	230	1255	135	54	118	470	1324	346	65	171	227	1300.6	1242
1200	1795	250	1510	135	54	118	490	1579	357	45	192	246	1555.6	1497
1400	1795	292	1510	177	41	171	490	1579	357	45	234	288	1555.6	1497

★ Note:

1. Diagram of unit with air return plenum, and the air return plenum has no filter
2. The air return plenum with filter has no air return flange
3. If shock absorption hook is used, special instructions should be given to the factory

High Static Pressure Duct - TFM

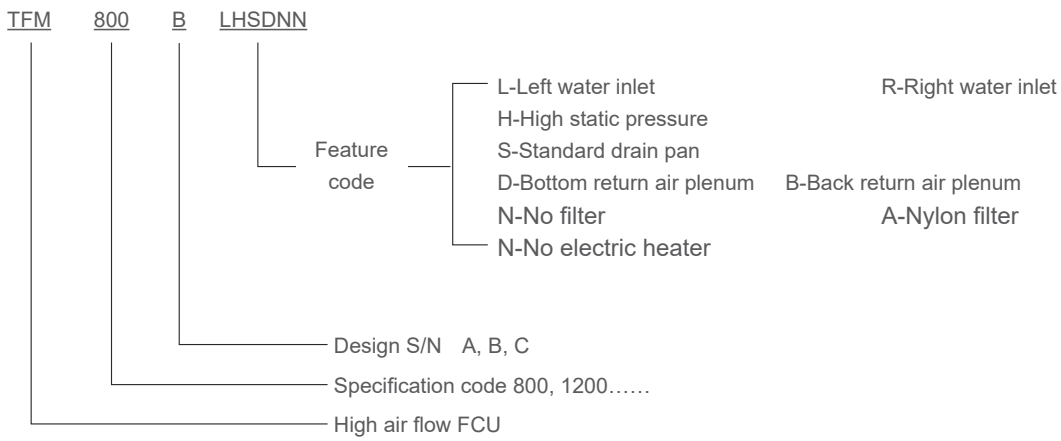

High Static Pressure Duct

Model TFM		800B	1000B	1200B	1600B	1800B	2000B	3000B
Rated Air Flow (m ³ /h)	High	1265	1510	1925	2490	2945	3880	5500
	Medium	1015	1215	1540	1990	2360	3100	4395
	Low	815	970	1230	1595	1890	2485	3520
Air Outlet Static Pressure (Pa)	High	130	130	130	130	130	130	130
Cooling Capacity (kW)	High	8.29	9.87	12.04	15.93	19.11	24.26	34.41
	Medium	6.64	7.90	9.63	12.75	15.29	19.39	27.51
	Low	5.30	6.31	7.70	10.20	12.22	15.53	22.01
Sensible Cooling Capacity (kW)	High	6.11	7.39	8.75	11.87	14.28	17.62	25.00
	Medium	4.89	5.91	6.99	9.51	11.42	14.09	19.98
	Low	3.92	4.73	5.60	7.61	9.14	11.29	15.99
Heating Capacity (kW)	High	12.37	15.19	19.60	24.56	28.66	39.47	55.99
	Medium	9.89	12.51	15.68	19.65	22.93	31.58	44.79
	Low	7.91	9.72	12.54	15.73	18.34	25.29	35.84
Power Input (W)	High	280	370	600	700	750	1200	1800
Sound Pressure Level (dB(A))	High	62	63	64	63	64.5	65	66
Fan	Type	Forward-curved multi-blade centrifugal fan (galvanized steel sheet)						
	Qty	1	1	1	2	2	2	3
Motor	Type	Single-phase capacitor motor						
	Insulation Class	B						
	Power Supply	220V~50Hz						
	Qty	1	1	1	1	2	2	3
Heat Exchanger	Structure Type	Aluminum-finned and copper-tube, mechanical expanding						
	Maximum Operating Pressure (MPa)	1.6MPa						
	Water Inlet/Outlet Pipe Diameter (inch)	R1 (taper pipe male threaded)					R1 ^{1/2} (taper pipe male threaded)	
	Water Flow (m ³ /h)	1.60	1.88	2.39	3.08	3.65	4.50	6.16
Water Pressure Drop (kPa)		6	14	25	20	25	35	45
Drain pan	Condensate Water Pipe Diameter	R1 (taper pipe male threaded)						
Dimensions	Length (mm)	860	860	960	1110	1260	1560	2010
	Width (mm)	820	820	820	820	820	820	820
	Height (mm)	430	430	430	430	430	430	430
Net Weight (kg)		50	50	56	65	76	94	126

Note:

1. Cooling capacity test conditions: supply water and return water temperatures 7/12°C; air return conditions: the dry/wet bulb temperature of air inlet is 27°C;
2. Heating capacity test conditions: supply water is 60°C, water quantity being the same as during cooling capacity test; air return conditions: the dry bulb temperature of air inlet is 21°C;
3. The air flow in the table is obtained when the unit is running in dry state and the dry bulb temperature is 20°C;
4. When FCU residual pressure consumption is 80Pa, moisture might occur;
5. Unless specified otherwise, the unit comes with the following return air plenum;
6. The sound pressure level in the table is obtained in a semi-anechoic chamber with noise at 11.5dB(A);

Dimension

High Pressure Duct FCU

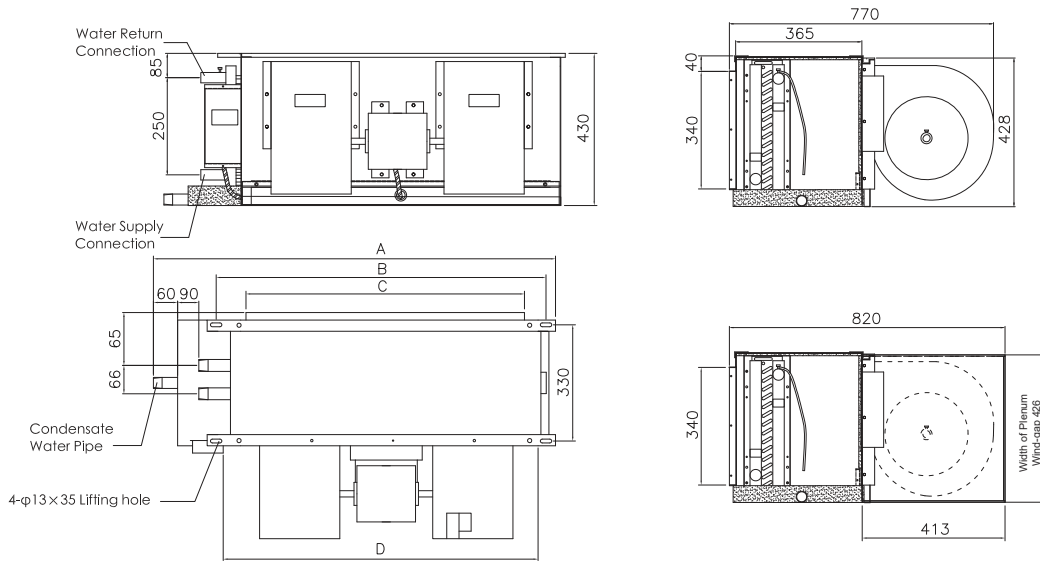

Model TFM	A	B	C	D	Inlet/outlet Pipe	Condensate Water Pipe	Motor Quantity (S/H)	Fan Quantity
800B	860	683	530	653	R1	R1	1/1	1
1000B	860	683	530	653	R1	R1	1/1	1
1200B	960	783	630	653	R1	R1	1/1	1
1600B	1110	953	800	753	R1	R1	1/1	2
1800B	1260	1083	930	923	R1	R1	1/2	2
2000B	1560	1403	1250	1373	R1 ^{1/2}	R1	2/2	2
3000B	2010	1853	1700	1823	R1 ^{1/2}	R1	3/3	3

Round Flow Cassette - TKM



Characteristics:

- 360° air outlet, no blind spot.
- Low noise
The quality heat insulating and anechoic material is used to minimize the unit vibration and noise. The 3D aerofoil-type blade fan with a large diameter is used to ensure low speed and low noise.
- Compact design, built-in drain pump

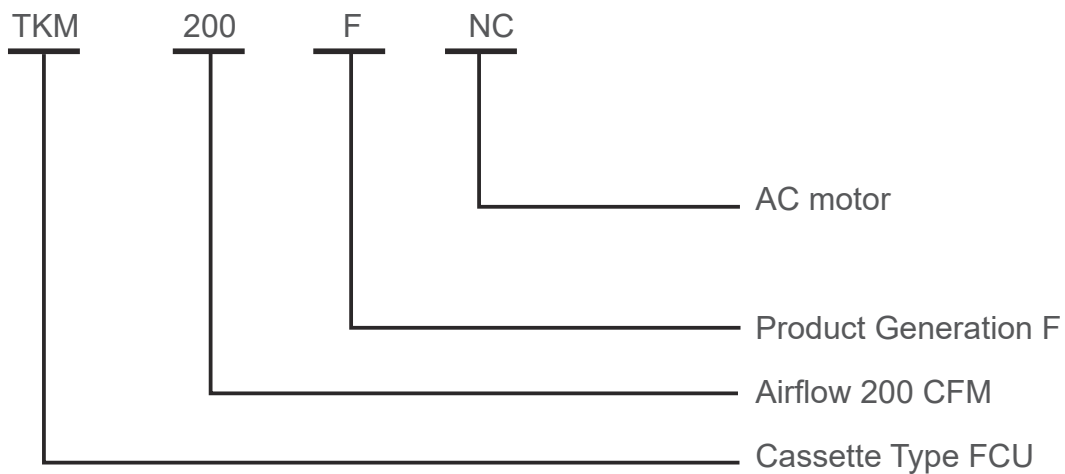
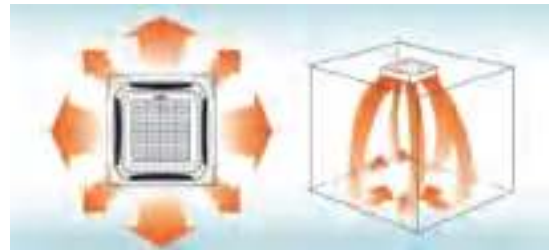

Round Flow Cassette

Model TKM		200FNC	300FNC	400FNC	500FNC	600FNC	800FNC	1000FNC	1200FNC	1400FNC
Rated Air Flow (m³/h)	High	340	510	680	850	1020	1360	1700	2040	2380
	Medium	290	420	560	650	870	1150	1450	1530	1780
	Low	210	350	460	520	715	950	1130	1250	1420
Cooling Capacity (W)	High	2300	3000	3700	4700	5600	7500	9000	11000	12600
	Medium	1800	2300	2700	3500	4200	5600	6700	8100	9300
	Low	1400	1800	2100	2900	3400	4500	5200	6300	7200
Heating Capacity (W)	High	3600	5000	6400	7400	9300	12500	15000	17600	18900
Power Input (W)	High	30	34	40	62	88	110	135	170	221
	Medium	26	28	30	46	73	85	105	136	180
	Low	24	26	28	37	60	67	82	105	130
FCEER	High	65	74	73	65	57	61	58	56	48
FCCOP	High	107	144	153	118	102	107	105	91	72
Sound Level (dB(A))	High	32	36	39	40	44	45	48	50	52
	Medium	29	33	35	35	36	38	43	45	48
	Low	26	28	32	32	32	34	38	41	43
Fan	Type	Centrifugal fan								
Motor	Type	Single-phase capacitor motor								
Heat exchanger	Structure Type	Efficient double-flanged aluminum fins and copper tubes, expanded into one								
	Maximum Operating Pressure (Mpa)	1.6								
	Water Inlet/Outlet Pipe Diameter (Inch)	Rc 3/4(Taper Pipe Female Threaded)								
	Water Flow (m³/h)	0.4	0.54	0.63	0.8	1.0	1.3	1.55	1.87	2.24
Water Resistance	kPa	20	20	25	30	30	40	40	40	50
Drain Pan	Condensate Water Pipe Diameter	Φ26								
Dimensions (Excluding Decorative Panel)	Length (mm)	660			660		760	836	860	
	Width (mm)	660			660		760	836	860	
	Height (mm)	200			290		290	290	290	
Decorative Panel Dimensions	Length (mm)	750					850		950	
	Width (mm)	750					850		950	
Net Weight	kg	16			20		24	27.5	28.5	

★ Note:

1. Cooling: supply water and return water temperatures 7/12°C; the dry/wet bulb temperature of air inlet is 27/19.5°C;
2. Heating: supply water is 60°C, water quantity being the same as during cooling; air return conditions: the dry bulb temperature of air inlet is 21°C;
3. The air flow in the table is obtained when the unit is running in dry state and the dry bulb temperature of air inlet is 20°C;
4. The sound pressure level in the table is obtained in a semi-anechoic chamber with noise at 11.5dB(A);
5. TKM***F series come with automatic guide plate drive mechanism and pump;

Dimension

Cassette Type FCU

TKM200-1400FNC

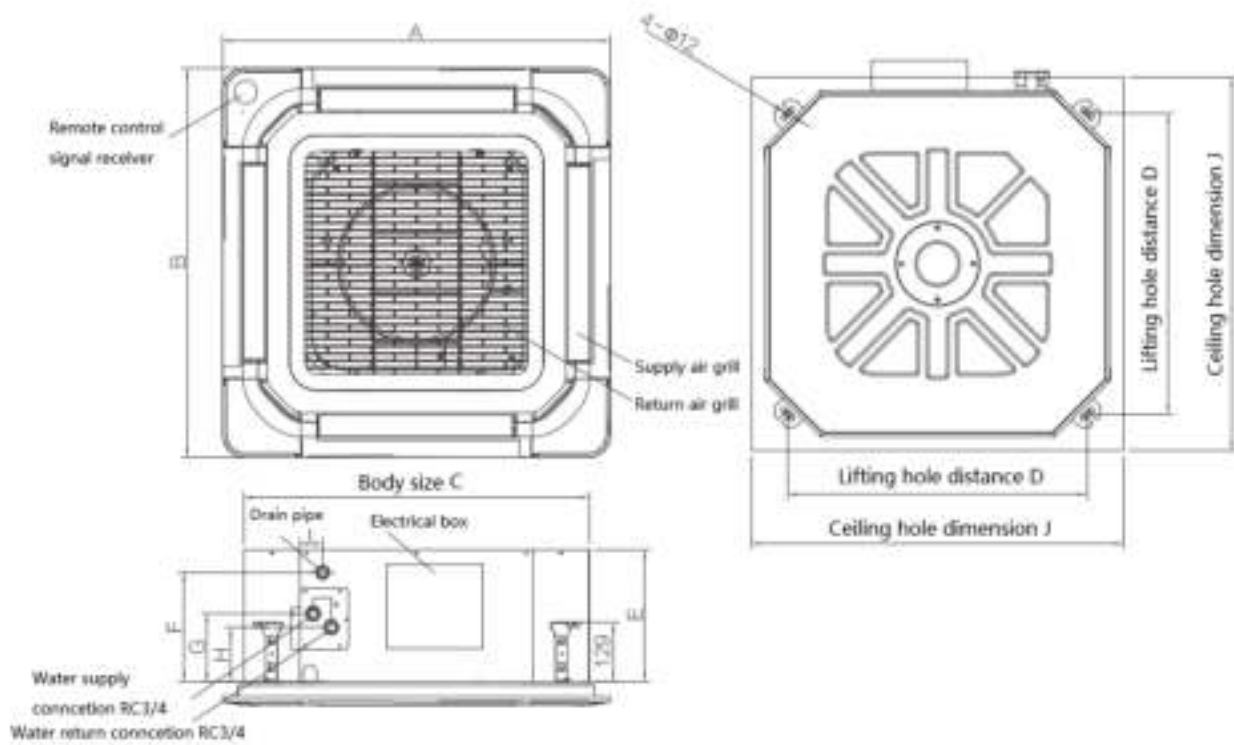

Model TKM	A	B	C	D	E	F	G	H	I	J
200/300/400	750	750	660	560	200	165	115	85	63	700
500/600	750	750	660	560	290	240	150	120	50	700
800/1000	850	850	760	660	290	240	150	120	50	800
1200	950	950	836	745	290	240	150	120	54	900
1400	950	950	860	745	290	240	150	120	54	900

Ceiling & Floor - TC



Characteristics:

- Flexible installation, ceiling or floor mounted
- Automatic horizontal and vertical air flow
- One side access hole ,easy for maintenance

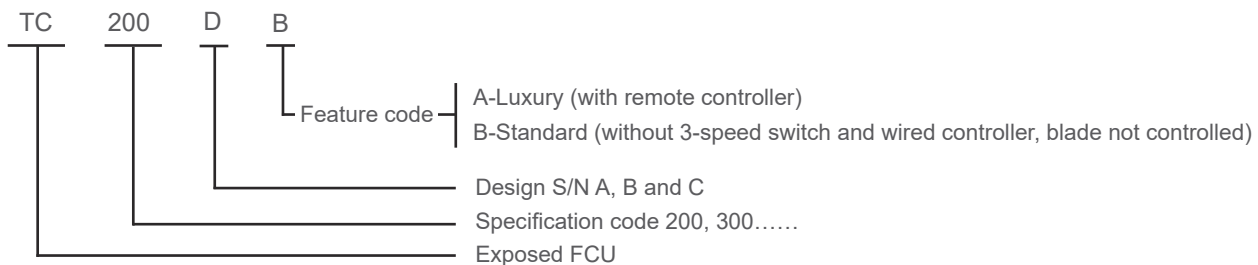

(Note: The pipes are connected on the right facing the unit. The unit is either floor mounted or ceiling mounted in a concealed manner)

Model TC		200D	300D	400D	500D	600D	800D	1000D	1200D	1400D
Rated Air Flow (m3/h)	High	350	520	680	850	1030	1360	1700	2040	2380
	Medium	280	440	560	700	870	1255	1450	1830	2100
	Low	230	350	410	570	740	1080	1160	1500	1650
Cooling Capacity (W)	High	1970	2850	3600	4300	5400	6600	8400	9600	10500
	Medium	1675	2400	3060	3655	4590	5610	7140	8160	8900
	Low	1380	1995	2520	3010	3780	4620	5880	6720	7350
Heating Capacity (W)	High	3200	4500	5600	6800	8600	10500	13500	15000	16800
	Medium	2680	3825	4760	5780	7310	8900	11500	12750	14280
	Low	2200	3150	3920	4760	6020	7350	9450	10500	11760
Power Input (W)	High	37	52	62	76	106	134	165	189	228
FCEER	High	51	52	54	52	49	46	48	47	42
FCCOP (Water Inlet: 60°C)	High	83	83	84	82	78	74	77	74	68
Sound Level (dB(A))	High	37	39	41	43	45	46	48	50	52
Fan	Type	Forward-curved multi-blade double inlet centrifugal fan								
Motor	Type	Single-phase capacitor motor								
Heat Exchanger	Structure Type	Efficient double-flanged aluminum fins and copper tubes, expanded into one								
	Maximum Operating Pressure (MPa)	1.6								
	Water Inlet/Outlet Pipe Diameter (inch)	Rc3/4 (Taper Pipe Female Threaded)								
	Water Flow (m3/h)	0.34	0.49	0.62	0.74	0.89	1.12	1.44	1.65	1.81
Water Resistance	kPa	12	14	22	26	15	20	20	24	29
Drain Pan	Condensate Water Pipe Diameter	Φ25								
Dimensions	Length (mm)	905			1288			1672		
	Width (mm)	243			243			243		
	Height (mm)	673			673			673		
Net Weight	kg	25			40			45		

★ Note:

1. Cooling: supply water and return water temperatures 7/12°C; the dry/wet bulb temperature of air inlet is 27/19.5°C;
2. Heating: supply water is 60°C, water quantity being the same as during cooling; air return conditions: the dry bulb temperature of air inlet is 21°C;
3. The air flow in the table is obtained when the unit is running in dry state and the dry bulb temperature of air inlet is 20°C;
4. The sound pressure level in the table is obtained in a semi-anechoic chamber with noise at 11.5dB(A);
5. TC***DB series do not contain a wired controller; TC***DA series contain a remote controller;
6. Thermostat is optional with three speed levels and can be connected to electric valve to realize temperature regulation;
7. The pipes are connected on the right facing the unit;
8. The unit can be in vertical or ceiling installation;

Dimension

Floor Ceiling Type FCU

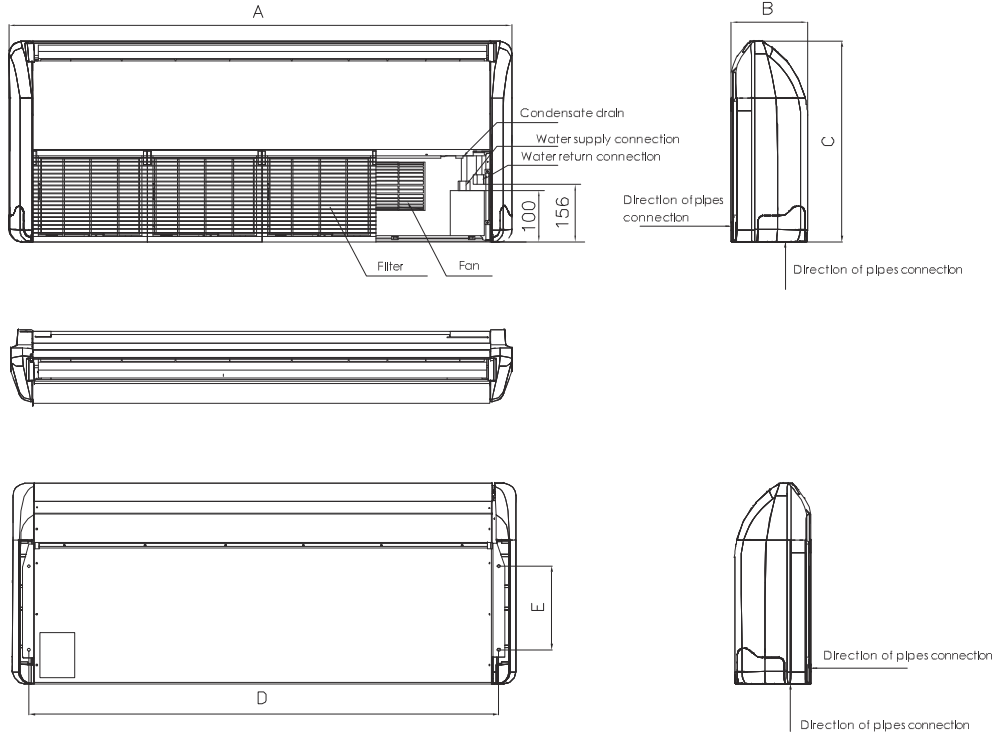

TC	200	300	400	500	600	800	1000	1200	1400
Dimension	905x243x673				1288x243x673		1672x243x673		
Steeve Pitch	801x280				1184x280		1569x280		
Fan Quantity	2	2	2	2	3	3	4	4	4

Note

15 horizontal grey bars for note-taking.

Note

12 horizontal bars for taking notes.



«TICA PRO» LLC

Tel: +7 (495) 127-79-00

E-mail: info@tica.pro

Website: <https://en.tica.pro/>



Note: Due to constant improvement and innovation of TICA's products, the product models, specifications and parameters contained in this document are subject to change without prior notice.