

**FORM NO.B4420G01**

**Industrial factory buildings**

**Hypermarkets**

**Dining halls**

**Stadiums and gymnasiums**

**Convention and exhibition centers**



**TICA PRO LLC**

**[www.tica.pro](http://www.tica.pro)**



# **DX MODULAR AIR HANDLING UNIT**

**TICA CENTRAL AIR-CONDITIONING**

# Established in 1991

TICA is a professional enterprise specialized in R&D, manufacturing, sales and services of environment cleaning and thermal energy utilization.

TICA is a national high-tech enterprise, a single leading enterprise cultivated by the Ministry of Industry and Information Technology, a national brand cultivation enterprise of the Ministry of Industry and Information Technology, and a vice chairman member of China Refrigeration and Air-conditioning Industry Association. It has a national-recognized enterprise technology center, an enterprise academician workstation, and a post-doctoral research workstation. Its projects cover Beijing Bird's Nest Stadium, Water Cube, Wukesong Indoor Stadium, PetroChina, Sinopec, State Grid, Nanjing Panda, Hangzhou Xiaoshan International Airport, Hainan Airlines Group, Shangri-La Hotel, Manila Ocean Park, Abu Dhabi Al Muneera, SM City in Philippines and Unilever, etc.

TICA is also the outstanding provider of central air conditioners for China's subway networks and has successfully served nearly 60 key subway lines in major cities such as Beijing, Shanghai, Guangzhou, Shenzhen, Chengdu, Suzhou, Hangzhou and Tianjin. TICA is a professional supplier and service provider in China that specializes in system integration of clean environment. While for microelectronics, hospital operating rooms, biopharmaceutical industry and other professional purification areas, our market share has achieved over 40% in each.

## TICA Quality For IAQ

TICA focuses on indoor air quality (IAQ) in clean environments. Product lines include return air purifiers, heat recovery ventilators, fresh air purifiers, air purifiers, as well as the clean air handling units and digital variable-capacity air handling units used in the professional purification field. Regarding core technology, TICA established an ISO class 1 super-clean environment integration system and won the first prize of CMIST.

In the field of thermal energy utilization, TICA's product lines include modular chillers, VRF units, screw chillers, centrifugal chillers, and ORC low-temperature waste heat power generation systems. In 2015, TICA and United Technologies Corporation (UTC) established a global strategic joint venture cooperation relationship and acquired PureCycle, an ORC low-temperature power generation company owned by Pratt & Whitney under UTC. TICA obtained PureCycle trademarks and more than 100 patents and national copyrights. TICA's efficient centrifugal chillers, water-cooled screw chillers, and air-cooled screw chillers are manufactured with the technical license of Carrier under UTC.

TICA is characterized by excellent system integration capability. In the application of "Efficient Refrigeration System of Underground Railway Station", the integrated COP of the refrigeration room amounts to 6.0, and the research achievement reaches the international advanced level. In 2018, TICA merged and acquired an OFC central air conditioning enterprise **SMARDT**. TICA's excellent system integration capability and the **SMARDT** world-class OFC water chillers help increase the integrated COP of the efficient equipment room to 6.7 to 7.0.

TICA---We're striving.

TICA aims to build itself into a world-leading system integration supplier and service provider that specializes in clean environment and thermal energy utilization.



# DIRECTORY

Product Overview	1
Nomenclature	2
Product Application Fields	3
Application System Solution of TICA's DX Products	4
Specifications	6
Dimensions	13
Precautions for Unit Installation and Use	15
Maintenance	19

TICA owns five production sites in Nanjing, Tianjin, Guangzhou, Chengdu and Kuala Lumpur, and a network of over 70 sales and service filiales around the world.

Its Nanjing HQ base received 3-star certification for national No. 001 green industrial construction.



Malaysia Base



Nanjing Headquarter



Tianjin Base



Guangzhou Base



Chengdu Base



## Product Overview



### TSAX008

Suitable for installation in small spaces



### TSAX012~062

Suitable for general clean rooms



### TSAX290~330

Suitable for general clean rooms

TICA's DX modular air handling units are classified into air-cooled cabinet type thermostatic and humidistatic AHUs, air-cooled purifying type air conditioning units, and deep dehumidification fresh air handling units.

TICA's air-cooled cabinet type thermostatic and humidistatic AHUs are tailored for places which raise strict requirements for temperature and humidity as well as cleanliness, such as pharmaceutical plants, medical treatment and public health, bioengineering, precision machinery, optical instruments, and electronic industry. The unit is equipped with a direct expansion and evaporation coil, and comes with multiple models and cooling capacities. It is flexibly designed, easy to install and supports expandable control.

TICA's air-cooled purifying type air conditioning unit applies to places which raise requirements for air cleanliness and temperature & humidity control, such as pharmaceutical plants, medical treatment and public health, bioengineering, food and beverage, and electronic industry, with the air-conditioning and purifying areas ranging from dozens to thousands of square meters. Compared to the water system design, the purifying type air conditioning unit is built upon TICA's patented labyrinth structure air handling unit and equipped with a direct expansion and evaporation coil, contributing to the simple system, easy installation and low cost of the unit.

TICA's deep dehumidification fresh air unit is intended for the air conditioning system solution with separate control of temperature and humidity. After being processed by the unit, the fresh air can independently bear indoor humidity load. The circulating air unit can operate in the dry conditions of high-temperature chilled water, without generation of condensate water and bacteria breeding. Therefore, the unit is clean and hygienic. The system boasts energy efficiency without the need of re-heating.

## Features



Compressors of famous brands undergo long-term running test under various harsh operating conditions exceeding national standards to ensure unit stability and reliability

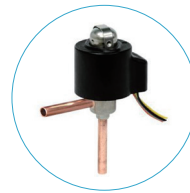

Electronic expansion valve implements throttling to ensure optimal operation of the unit under various harsh operating conditions



The newly optimized control logic ensures stable and reliable operation and excellent performance of the unit

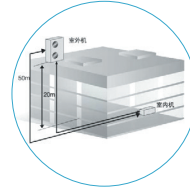

Long piping design adopted to meet the air conditioning design requirements of buildings with a longer distance between the IDU and ODU



Implementing the heat pump function, economic and energy saving



The newly designed electric control cabinet layout and interactive interface of touch screen simplify operations

## Nomenclature

### IDU model

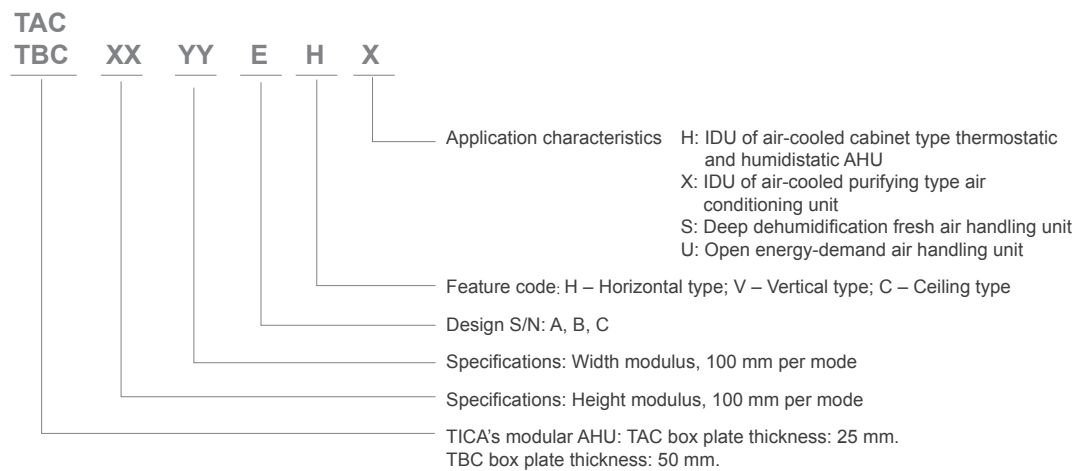

### ODU model

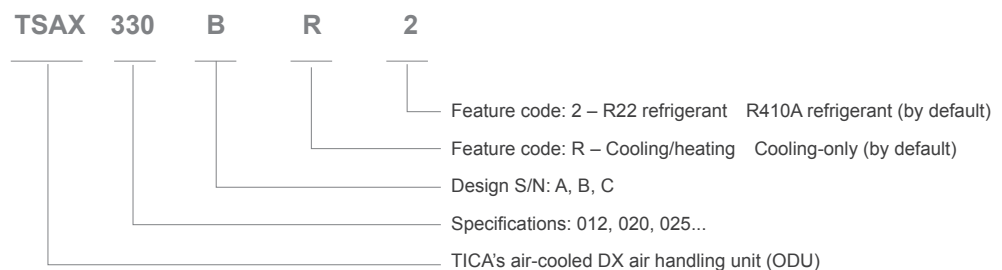

## Product Application Fields



Clean operating room



Inspection and quarantine



Medical laboratory

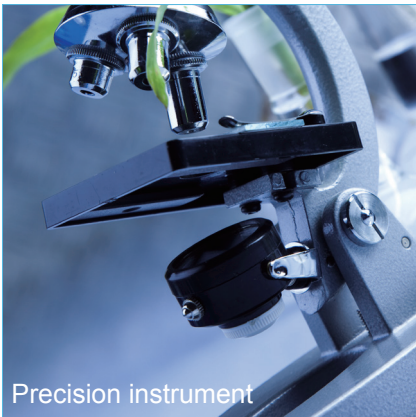

Precision instrument

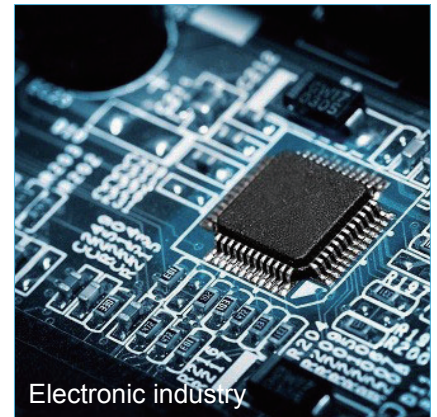

Electronic industry



Pharmaceuticals



Food processing



Cosmetic industry



# Application System Solution of TICA's DX Products

## I. Full air return form

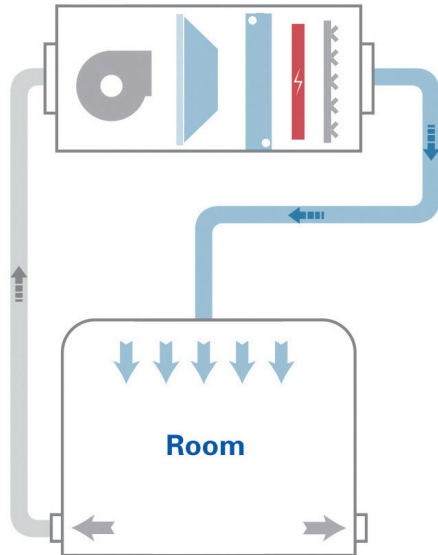

Model: Air-cooled purifying type air conditioning unit  
Applicable to: Application sites without fresh air

## II. Primary return air with fresh air DX solution/Secondary return air with fresh air DX solution

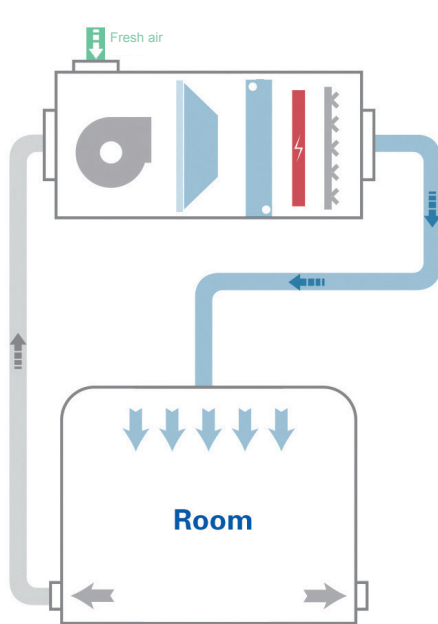

Primary air return

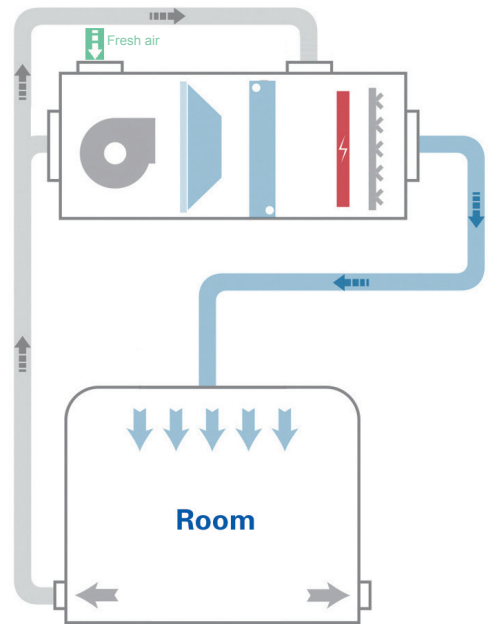

Secondary air return

Model: Air-cooled purifying type air conditioning unit  
Applicable to: Application sites with partial fresh air. The primary air return solution applies to the site with a low ventilation frequency; the secondary air return solution applies to the site with a high ventilation frequency or the air flow of selected model far surpassing the nominal air flow.

### III. Primary air return + fresh air pre-handling

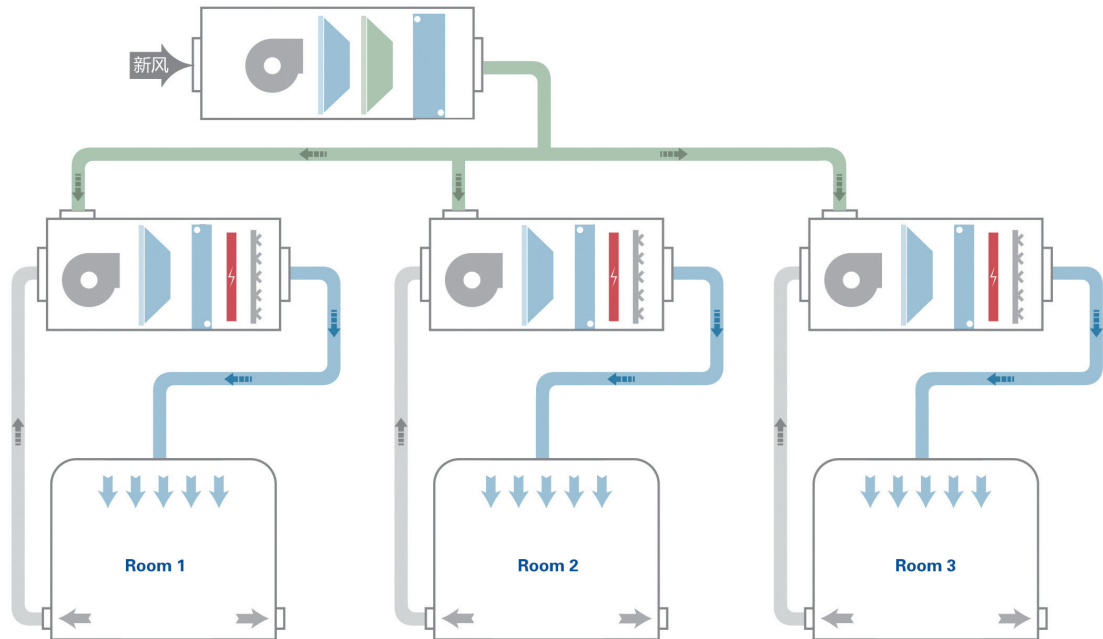

Fresh air unit: Air-cooled DX all fresh air unit

Circulating air unit: Air-cooled purifying type air conditioning unit

Applicable to: Application sites with a greater fresh air ratio



## Specifications

### Specifications of Air-Cooled Cabinet Type Thermostatic and Humidistatic AHU & Air-Cooled Purifying Type Air Conditioning Unit (R410A)

Model		IDU	TAC	0607	0608	0810	0813	1013	1115	1117	
		IDU fluorine coil	TSD	008BM	016BM	025CM	030CM	041CM	052CM	062CM	
			ODU	TSAX	008BR	008BR*2	025C(R)	030C(R)	041C(R)	052C(R)	062C(R)
System parameters	Rated cooling capacity 1 (cooling-only type/heat pump type)	kW	7.5	15	25.5	30	41	52	62		
	Rated cooling capacity 2 (cooling-only type/heat pump type)	kW	8.0	16.1	27.3	32.1	43.9	55.6	66.3		
	Heating capacity (heat pump type)	kW	8	16	28.5	34.1	44	55	68		
IDU	Air flow	m <sup>3</sup> /h	1400	2400	5000	6000	7500	10000	12000		
	Cooling coil section length for reference	mm	500	500	500	500	500	600	600		
	Temperature setting range and precision	-	20°C~26°C (Cooling only constant temperature and humidity type: ±1°C; heat pump/other type: ±2°C)								
	Humidity setting range and precision	-	45%~65% (Constant temperature and humidity, cooling only: ±5%; heat pump: ±10%; other types: no precision)								
	Power supply	-	380V 3N ~ 50Hz								
	Electric heater	Power	kW	8	12	16	20	24	32	38	
	Humidifier	Type	-	Electrode humidifier (Electric heating humidifier is optional)							
		Power	kW	3.8	3.8	6.0	11.3	11.3	11.3	18.8	
Humidifying capacity		kg/h	5	5	8	15	15	15	25		
ODU	Compressor type		Rotary compressor			Hermetic scroll compressor					
	Outer dimensions (single set)	Length	mm	865	865	1403	1403	1403	1808	1808	
		Width	mm	350	350	821	821	821	1090	1090	
		Height	mm	700	700	1200	1200	1200	1214	1214	
	Weight (single set)	kg	56	56	245	270	280	415	455		
	Power supply		220V 1N ~ 50Hz			380V 3N ~ 50Hz					
	Power input	kW	2.4	4.8	8.71	10.04	13.85	16.98	19.65		
Rated current	A	11.1	22.2	19.03	22.01	25.45	31.93	36.80			
Refrigerant	Charge amount	kg	2.1	2.1*2	3.4*2	3.6*2	4.35*2	6.7*2	7.2*2		
Connection pipe	ODU connection mode		Pipe socket				Welding				
	Dimensions	Liquid pipe	φmm	6.35	6.35*2	9.52*2	9.52*2	12.7*2	12.7*2	12.7*2	
		Gas pipe	φmm	15.88	15.88*2	15.88*2	15.88*2	19.05*2	22.23*2	25.4*2	

★ **Remarks:**

- The rated cooling capacity 1 is tested under the nominal air flow, when the indoor dry/wet bulb temperature is 24/17°C and the outdoor dry/wet bulb temperature is 35/24°C. The rated cooling capacity 2 is tested under the nominal air flow, when the indoor dry/wet bulb temperature is 27/19°C and the outdoor dry/wet bulb temperature is 35/24°C.
- The rated heating capacity is tested under the nominal air flow, when the indoor dry/wet bulb temperature is 20/15°C and the outdoor dry/wet bulb temperature is 7/6°C.
- The rated cooling capacity does not take into account the heating loss of fan motor. The nominal air flow refers to the operating air flow under the standard condition.
- The standard configuration of the unit includes an electric heater, and hot water or steam heating can be adopted according to the customer's requirements.
- The ODU dimensions provided in the parameter table are the external dimensions of single unit.
- The standard electric heater in the sample is an auxiliary electric heater, and the secondary heating quantity in winter should be accounted for separately.
- Piping condition of unit performance test: Equivalent refrigerant length 7.5 m (horizontal).
- R22 has been charged in the ODU. For the charge quantity, refer to the nameplate.
- Ambient temperature range for operation of the ODU: TSAX008BR cooling: 0°C≤T≤46°C; heating: -10°C≤T≤25°C.  
TSAX025~062C(R) cooling: 0°C≤T≤46°C; heating: -15°C≤T≤25°C.  
TSAX290~330B(R) cooling: -10°C≤T≤46°C; heating: -10°C≤T≤30°C.

★ **Note: ODUs include:**

one set of TSD008BM, TSD025CM, TSD030CM, TSD041CM, TSD052CM, TSD062CM, TSD290BM, or TSD330BM ODU;  
 The TSD016BM ODU consists of two TSAX008BR ODUs;  
 The TSD082CM ODU consists of two TSAX041C(R) ODUs;  
 The TSD104CM ODU consists of two TSAX052C(R) ODUs;  
 The TSD124CM ODU consists of two TSAX062C(R) ODUs;  
 The TSD156CM ODU consists of three TSAX052C(R) ODUs;  
 The TSD186CM ODU consists of three TSAX062C(R) ODUs.

## Specifications of Air-cooled Cabinet Type Thermostatic and Humidistatic AHU & Air-Cooled Purifying Type Air Conditioning Unit (R410A)

Model		IDU	TAC	1218	1521	1622	1923	2026	2528	2528
			TBC							
		IDU fluorine coil	TSD	082CM	104CM	124CM	156CM	186CM	290BM	330BM
		ODU	TSAX	041C(R)*2	052C(R)*2	062C(R)*2	052C(R)*3	062C(R)*3	290BR	330BR
System parameters	Rated cooling capacity 1 (cooling-only type/heat pump type)		kW	79	104	124	156	186	250	286
	Rated cooling capacity 2 (cooling-only type/heat pump type)		kW	84.5	111.3	132.7	166.9	199.0	270	310
	Heating capacity (heat pump type)		kW	83	110	136	165	204	270	310
IDU	Air flow		m <sup>3</sup> /h	15000	18500	23500	28000	34500	47000	52000
	Cooling coil section length for reference		mm	600	600	600	800	800	900	900
	Temperature setting range and precision		-	20°C~26°C (Cooling only constant temperature and humidity type: ±1°C; heat pump/other type: ±2°C)						
	Humidity setting range and precision		-	45%~65% (Constant temperature and humidity, cooling only: ±5%; heat pump: ±10%; other types: no precision)						
	Power supply		-	380V 3N ~ 50Hz						
	Electric heater	Power	kW	48	60	80	90	120	120	120
		Type	-	Electrode humidifier (Electric heating humidifier is optional)						
	Humidifier	Power	kW	18.8	26.3	33.8	49	49	49	49
		Humidifying capacity	kg/h	25	35	45	65	65	65	65
ODU	Compressor type			Hermetic scroll compressor						
	Outer dimensions (single set)	Length	mm	1403	1808	1808	1808	1808	2200	2200
		Width	mm	821	1090	1090	1090	1090	2400	2400
		Height	mm	1200	1214	1214	1214	1214	2235	2235
	Weight (single set)		kg	280	415	455	415	455	1570	1570
	Power supply			380V 3N ~ 50Hz						
	Power input		kW	25.89	33.96	39.30	51.78	58.95	84	92.4
Rated current		A	49.10	63.86	73.60	98.20	110.40	150.6	165.9	
Refrigerant	Charge amount		kg	4.35*4	6.7*4	7.2*4	6.7*6	7.2*6	13.5*4	13.5*4
Connection pipe	ODU connection mode			Pipe socket			Welding			
	Dimensions	Liquid pipe	φmm	12.7*4	12.7*4	12.7*4	12.7*6	12.7*6	19.05*4	19.05*4
		Gas pipe	φmm	19.05*4	22.23*4	25.4*4	22.23*6	25.4*6	34.92*4	34.92*4

★ Remarks:

- The rated cooling capacity 1 is tested under the nominal air flow, when the indoor dry/wet bulb temperature is 24/17°C and the outdoor dry/wet bulb temperature is 35/24°C. The rated cooling capacity 2 is tested under the nominal air flow, when the indoor dry/wet bulb temperature is 27/19°C and the outdoor dry/wet bulb temperature is 35/24°C.
- The rated heating capacity is tested under the nominal air flow, when the indoor dry/wet bulb temperature is 20/15°C and the outdoor dry/wet bulb temperature is 7/6°C.
- The rated cooling capacity does not take into account the heating loss of fan motor. The nominal air flow refers to the operating air flow under the standard condition.
- The standard configuration of the unit includes an electric heater, and hot water or steam heating can be adopted according to the customer's requirements.
- The ODU dimensions provided in the parameter table are the external dimensions of single unit.
- The standard electric heater in the sample is an auxiliary electric heater, and the secondary heating quantity in winter should be accounted for separately.
- Piping condition of unit performance test: Equivalent refrigerant length 7.5 m (horizontal).
- R22 has been charged in the ODU. For the charge quantity, refer to the nameplate.
- Ambient temperature range for operation of the ODU: TSAX008BR cooling: 0°C≤T≤46°C; heating: -10°C≤T≤25°C.  
TSAX025~062C(R) cooling: 0°C≤T≤46°C; heating: -15°C≤T≤25°C.  
TSAX290~330B(R) cooling: -10°C≤T≤46°C; heating: -10°C≤T≤30°C.

★ Note: ODUs include:

one set of TSD008BM, TSD025CM, TSD030CM, TSD041CM, TSD052CM, TSD062CM, TSD290BM, or TSD330BM ODU;  
 The TSD016BM ODU consists of two TSAX008BR ODUs;  
 The TSD082CM ODU consists of two TSAX041C(R) ODUs;  
 The TSD104CM ODU consists of two TSAX052C(R) ODUs;  
 The TSD124CM ODU consists of two TSAX062C(R) ODUs;  
 The TSD156CM ODU consists of three TSAX052C(R) ODUs;  
 The TSD186CM ODU consists of three TSAX062C(R) ODUs.





## Specifications of Air-cooled DX All Fresh Air Unit (R410A)

Model	IDU		0610	0711	0813	0814	1015	1017	1119	1319	1924	1924	
	ODU	TAC TBC	025C(R)	030C(R)	041C(R)	052C(R)	062C(R)	041C(R)*2	052C(R)*2	062C(R)*2	290BR	330BR	
System parameters	Air flow	m <sup>3</sup> /h	2450	3000	4000	5000	7000	8000	10000	14000	24000	26000	
	Air flow range	m <sup>3</sup> /h	Standard air flow ±5%										
	Cooling capacity	kW	25.5	30.0	41.0	51.0	61.0	82.0	105.0	121.0	290.0	332.0	
	Heating capacity	kW	28.5	34.1	41.5	55.0	68.0	83.0	110.0	135.0	280.0	320.0	
IDU	Cooling coil section length for reference	mm	600	700	700	800	800	800	800	800	800	800	
	IDU coil	TSD	025CFM	030CFM	041CFM	052CFM	062CFM	082CFM	104CFM	124CFM	290BFM	330BFM	
	Fan form	-	Belt-driven low noise centrifugal type										
ODU	Power supply	-	380V 3N~50Hz										
	Compressor type	-	Hermetic scroll compressor										
	Outer dimensions (single set)	Length	mm	1403	1403	1403	1808	1808	1403	1808	1808	2200	2200
		Width	mm	821	821	821	1090	1090	821	1090	1090	2400	2400
		Height	mm	1200	1200	1200	1214	1214	1200	1214	1214	2235	2235
	Weight (single set)	kg	245	270	280	415	455	280	415	455	1570	1570	
	Power supply	-	380V 3N ~ 50Hz										
	Power input	Cooling	kW	8.71	10.04	13.85	16.98	19.65	25.89	33.96	39.30	89.30	98.30
		Heating	kW	8.25	9.96	13.00	16.13	19.00	23.60	32.26	38.00	80.30	88.30
	Rated current	Cooling	A	19.03	22.01	25.45	31.93	36.80	49.10	63.86	73.60	156.50	172.40
Heating		A	18.03	21.81	23.95	29.63	34.90	43.40	59.26	69.80	144.20	158.80	
Refrigerant	Model	-	R410A										
	Charge quantity (cooling-only type/heat pump type)	kg	3.4*2	3.6*2	4.35*2	6.7*2	7.2*2	4.35*4	6.7*4	7.2*4	13.5*4	13.5*4	
Connection pipe	Connection mode	-	Pipe socket				Welding						
	Dimensions	Liquid pipe	φmm	9.52*2	9.52*2	12.7*2	12.7*2	12.7*2	12.7*4	12.7*4	12.7*4	19.05*4	19.05*4
		Gas pipe	φmm	15.88*2	15.88*2	19.05*2	22.23*2	25.4*2	19.05*4	22.23*4	25.4*4	34.92*4	34.92*4

### ★ Remarks:

- The rated cooling capacity is tested under the nominal air flow, when the outdoor dry/wet bulb temperature is 34/28°C.
- The rated heating capacity is tested under the nominal air flow, when the outdoor dry/wet bulb temperature is 7/6°C.
- Piping condition of unit performance test: Equivalent refrigerant length 7.5 m (horizontal).
- When the electric heater is used to pre-heat fresh air, the IDU length should be added by 300 mm.
- R410A refrigerant has been charged into the ODU. For the charge quantity, refer to the nameplate.
- The fresh air unit is used for handling fresh air only.
- The specification parameters may be changed due to product improvement without a prior notice. The parameters indicated on the unit nameplate should prevail.
- When the heat pump type is used for heating at a temperature below 0°C, a preheating section needs to be configured to implement preheating to a temperature above 0°C.
- Ambient temperature range for operation of the ODU: TSAX025C(R)~TSAX062C(R) cooling: 20°C≤T≤43°C; heating: -15°C≤T≤15°C; TSAX290B(R)~TSAX330B(R) cooling: 17°C≤T≤46°C; heating: -10°C≤T≤21°C.

## Control System Specification (Parameters and Configuration)

Model		EHH/EVH/ECH	EHX/EVX/ECX	EHU/EVU/ECU	CHX/CVX/CCX	BHS	
Product features		Standard constant temperature and humidity	Purification type	Open energy-demand control	Fresh air pre-handling	Deep dehumidification fresh air handling unit	
Cooling/heating type		Cooling-only/heat pump	Cooling-only/heat pump	Cooling-only/heat pump	Cooling-only/heat pump	Cooling only	
Control object		Air return	Air return	Air return	Fresh air	Fresh air	
Control precision	Temperature	Scope	20°C~26°C	20°C~26°C	/	/	
		Precision	Cooling-only: ±1°C; heat pump: ±2°C	±2°C	/	/	/
	Humidity	Scope	45%~65%	45% ~ 65%	/	/	/
		Precision	Cooling-only: ±5%; heat pump: ±10%	±10%	/	/	/
Control cabinet	Main controller type		Single-chip microcomputer	Single-chip microcomputer	Single-chip microcomputer	Single-chip microcomputer	Single-chip microcomputer (section)
	Operating mode		Auto/Cooling/Heating/Ventilation	Auto/Cooling/Heating/Ventilation	/	Cooling/Heating/Ventilation	/
	Timed on/off		Yes	Yes	No	Yes	Yes
	RS485 monitoring interface		Yes	Yes	Yes	Yes	Yes
	ODU power air switch		Yes	Yes	No	No	No
	Sterilizing device		Optional	No	No	No	No
	Man-machine interface	Type	Capacitive touch screen 	LCD wired controller 	No	LCD wired controller with mechanical buttons 	LCD wired controller with mechanical buttons 
		Local touch screen	7 inches (default)	No	No	No	No
		External touch screen	Optional	No	No	No	No
	Monitoring dry contact	Remote start/stop	Yes	Yes	No	Yes (7.5 HP and above)	No
		Operating status indicator	Yes	Yes	No	No	Available in split-type units
		Fault status indicator	Yes	Yes	No	No	Available in split-type units
	Interlocking passive dry contact	Fire valve interlock	Yes	Yes	No	Yes	Yes
		Firefighting monitoring interlocking	Yes	Yes	No	Yes	No
		Discharge fan	Yes	Yes	No	No	No
		Rotary heat recovery interlocking	No	No	No	No	No
		Rotary dehumidifier interlocking	No	No	No	No	No
		Ozone sterilization	Optional	No	No	No	No
		Ultraviolet disinfection	Optional	No	No	No	No
	Electrostatic precipitator	No	No	No	No	No	
	Protection functions	Air loss protection(Including differential pressure switch)	Yes	Yes	Yes	Yes	Yes
		Over-temperature power-off protection of electric heater	Yes	Yes	No	Yes (Configured when an electric heater is available)	No
		Primary/medium/high efficiency filter alarm (excluding the differential pressure switch)	Yes	Yes	No	No	No
Antifreeze switch of the hot water coil		No	No	No	No	No	
Overheat protection of steam heating		No	No	No	No	No	
Emergency stop button		Cabinet door + IDU cabinet	Cabinet door + IDU cabinet	No	No	No	

★ Remarks:

The above configuration is the standard configuration for product control. For other requirements of non-standard control items, the customer can consult TICA.



## Specifications of Deep Dehumidification Fresh Air Handling Unit (Integral)

Model	TAC	1013	1015	1116	1317	
	TBC					
Air flow	m <sup>3</sup> /h	6500	8000	10000	12500	
Air flow range	m <sup>3</sup> /h	Standard air flow * 60% ≤ Air flow ≤ Standard air flow * 110%				
Number of optional rows of water coil		6 to 8 rows				
Deep dehumidification module	Compressor HP	-	4Hp	5Hp	6Hp	8Hp
	Cooling capacity of the evaporator	kW	12	14.5	18.5	23.2
	Heating capacity of the condenser	kW	15.2	18.2	22.7	28.7
	Dew-point temperature range of the air inlet machine of the evaporator	°C	12°C ~ 18°C			
	Compressor type	-	Hermetic scroll compressor			
	Rated power input of the compressor	kW	2.70	3.5	3.7	4.2
	Rated current of the compressor	A	4.9	6.6	7.1	8.1
	Refrigerant	Model	R410A			
		Charge amount	2.6	2.8	3.2	3.8
	Module section length	mm	1200			
Fan form	-	Belt-driven low noise centrifugal type				
Power supply of the unit	-	380V 3N~50Hz				
Connected water diameter of condensed water tray	-	DN32				

## Specifications of Deep Dehumidification Fresh Air Handling Unit (Split-type)

Model	IDU	TAC	0813	1013	1015	1116	1317	1420	
		TBC							
	ODU	TSA(X)	075N	025C	030C	041C	052C	062C	
Air flow range		m <sup>3</sup> /h	4950~6120	6120~7920	7650~9700	9700~12100	12100~15300	15300~18700	
Number of optional rows of water coil			6 to 8 rows						
Deep dehumidification module IDU	Cooling capacity of the evaporator	Kw	19.5	25.5	30	41	52	62	
	Dew-point temperature range of the air inlet machine of the evaporator	°C	12~18°C						
	Module section length	mm	800						
ODU	Power supply	-	380V 3N~50HZ						
	Outer dimensions (single set)	Length	mm	1403	1403	1403	1403	1808	1808
		Width	mm	821	821	821	821	1090	1090
		Height	mm	1200	1200	1200	1200	1214	1214
	Weight (single set)	kg	220	245	270	280	415	455	
	Compressor form	-	Hermetic scroll compressor						
	Rated power input of the compressor	kW	8	10	11.9	15	20.8	24.5	
	Rated current of the compressor	A	17.2	18.87	22.45	28.3	39.25	46.23	
Refrigerant	Model	-	R410A						
	Charge amount	kg	3.0*2	3.4*2	3.6*2	4.35*2	6.7*2	7.2*2	
Connection pipe	Connection mode		Pipe socket				Welding		
	Dimensions	Liquid pipe	φmm	9.52*2	9.52*2	9.52*2	12.7*2	12.7*2	12.7*2
		Gas pipe	φmm	15.88*2	15.88*2	15.88*2	19.05*2	22.23*2	25.4*2

### ★ Remarks:

- The cooling capacity of the integral deep dehumidification module is measured when air inlet dry/wet bulb temperature of the evaporator is 14/13.5°C under nominal air flow. The cooling capacity of the split-type deep dehumidification module is measured when air inlet dry/wet bulb temperature of the evaporator is 16/15.5°C under nominal air flow.
- Before delivery, the integral deep dehumidification module has been charged with refrigerant, while the ODU of the split-type deep dehumidification module has been charged with refrigerant and uses nitrogen to hold pressure.
- The compressor of the integral deep dehumidification module is located inside the cabinet, without an ODU.
- The specification parameters may be changed due to product improvement without a prior notice. The parameters indicated on the unit nameplate should prevail.

## Performance Change Table

### 1. Impact on cooling operation by indoor and outdoor conditions Air-cooled cabinet type thermostatic and humidistatic AHUs/Air-cooled purifying type air conditioning unit

Correction coefficient	Indoor wet bulb temperature (°C)								
		15	16	17	18	19	20	21	22
	Outdoor dry bulb temperature (°C)								
	25	1.041	1.095	1.121	1.137	1.153	1.165	1.179	1.181
	30	1.000	1.039	1.071	1.095	1.119	1.165	1.163	1.171
	35	0.925	0.961	1.000	1.039	1.076	1.086	1.092	1.102
	40	0.831	0.875	0.911	0.954	1.000	1.056	1.076	1.095
	43	0.782	0.823	0.887	0.916	0.971	0.988	1.028	1.034

★ Remarks:

1. During cooling operation, the main factors affecting the cooling capacity are the indoor wet bulb temperature and outdoor dry bulb temperature. The outdoor wet bulb temperature and indoor dry bulb temperature affect the cooling capacity slightly. Therefore, the indoor dry bulb temperature and outdoor wet bulb temperature are ignored in the above table.
2. The above table reflects the approximate change trend of air conditioning unit with the indoor and outdoor conditions. It can be used a reference only during model selection by the customer.

### 2. Impact on cooling operation by indoor and outdoor conditions Air-cooled cabinet type thermostatic and humidistatic AHUs/Air-cooled purifying type air conditioning unit

Correction coefficient	Indoor wet bulb temperature (°C)															
		14	12	10	8	6	4	2	0	-2	-4	-6	-8	-11	-13	-15
	Outdoor dry bulb temperature (°C)															
	10	1.241	1.192	1.157	1.119	1.081	1.052	0.984	0.921	0.862	0.807	0.757	0.712	0.671	0.634	0.602
	15	1.196	1.159	1.131	1.085	1.043	0.998	0.930	0.867	0.808	0.753	0.703	0.658	0.617	0.580	0.548
	20	1.172	1.136	1.095	1.053	1.000	0.964	0.897	0.834	0.775	0.720	0.669	0.622	0.579	0.540	0.505
	25	1.139	1.099	1.052	1.016	0.967	0.898	0.833	0.772	0.716	0.663	0.615	0.570	0.530	0.494	0.462

★ Remarks:

1. During cooling operation, the main factors affecting the cooling capacity are the indoor wet bulb temperature and outdoor dry bulb temperature. The outdoor wet bulb temperature and indoor dry bulb temperature affect the cooling capacity slightly. Therefore, the indoor dry bulb temperature and outdoor wet bulb temperature are ignored in the above table.
2. The above table reflects the approximate change trend of air conditioning unit with the indoor and outdoor conditions. It can be used a reference only during model selection by the customer.

### 3. Impact on the cooling capacity by IDU air flow changes

IDU rated air flow (%)	80	90	100	110	120
Cooling capacity correction coefficient	0.91	0.96	1	1.02	1.04

### 4. When the IDU and ODU connecting pipe is too long or the height difference of IDU and ODU is too large, the cooling capacity will be affected (for the maximum pipe length, refer to the attached table).

The cooling capacity correction coefficient is provided below:

Influence factor		Cooling capacity correction coefficient									
Equivalent total length of connecting pipe (m)		5	10	15	20	25	30	35	40	45	50
Height difference between the ODU and IDU	0m	1.00	0.99	0.97	0.95	0.93	0.91	0.89	0.87	0.85	0.83
	5m	1.00	0.98	0.96	0.94	0.92	0.90	0.88	0.86	0.84	0.82
	10m	-	0.97	0.95	0.93	0.91	0.89	0.87	0.85	0.83	0.81
	15m	-	-	0.94	0.92	0.90	0.88	0.86	0.84	0.82	0.80
	20m	-	-	-	0.91	0.89	0.87	0.85	0.83	0.81	0.79
	25m	-	-	-	-	0.88	0.86	0.84	0.82	0.80	0.78

★ Remarks:

1. The equivalent pipe length refers to the length of the straight pipe section of the pipeline plus the equivalent length of the elbow and the oil trap.

## 5. Equivalent lengths of elbow and oil trap

Outer diameter of gas connection pipe (mm)	Φ9.52 (3/8")	Φ12.7 (1/2")	Φ15.88 (5/8")	Φ19.05 (3/4")	Φ28.6 (1-1/8")	Φ34.9 (1-3/8")	Φ38.09 (1-1/2")
Elbow (m)	0.2	0.25	0.3	0.35	0.55	0.55	0.55
Oil trap (m)	1.4	1.8	2	2.4	3.7	4.1	4.1

## 6. Allowed maximum pipeline length and maximum number of elbows

ODU model	Refrigerant pipeline size		Limit length/height difference (m) of connecting pipe	Maximum number of elbows
	Gas pipe (mm)	Liquid pipe (mm)		
TSAX012(R22)	Φ19.05	Φ12.7	35/20	10
TASX020(R22)	Φ19.05*2	Φ12.7*2	35/20	10
TASX025(R22)	Φ19.05*2	Φ12.7*2	35/20	10
TSAX030(R22)	Φ19.05*2	Φ12.7*2	35/20	10
TSAX041(R22)	Φ25.4*2	Φ15.88*2	35/20	10
TSAX052(R22)	Φ28.6*2	Φ15.88*2	50/25	15
TSAX062(R22)	Φ28.6*2	Φ15.88*2	50/25	15
TSAX008(R410A)	Φ15.88	Φ6.35	15/10	6
TASX025(R410A)	Φ15.88*2	Φ9.52*2	25/15	6
TSAX030(R410A)	Φ15.88*2	Φ9.52*2	25/15	6
TSAX041(R410A)	Φ19.05*2	Φ12.7*2	35/20	10
TSAX052(R410A)	Φ19.05*2	Φ12.7*2	35/20	10
TSAX062(R410A)	Φ25.4*2	Φ12.7*2	35/20	10
TSAX290(R410A)	Φ34.9	Φ19.5	40/20	10
TSAX330(R410A)	Φ34.9	Φ19.5	40/20	10

## 7. Electrical Parameter Table of Air-cooled Air Conditioning Unit ODU — Heat Pump Type

Model	ODU TSAX	008BR	012*R	020*R	025*R	030*R	041*R	052*R	062*R
Power supply	220V~50Hz			380V 3N~50Hz					
Power cord	Type	ODU	ODU	ODU	ODU	ODU	ODU	ODU	ODU
	Sectional area mm <sup>2</sup>	2.5	4	6	6	6	10	10	10
	Pieces	3	5	5	5	5	5	5	5
Unit connecting wire	Sectional area mm <sup>2</sup>	2.5	2.5*2+1.5*5	1.5	1.5	1.5	1.5	1.5	1.5
	Pieces	6	7	2	2	2	2	2	2

Model	ODU TSAX	290BR			330BR		
Power supply	380V 3N~50Hz						
Power cord	Type	ODU			ODU		
		Live wire	Neutral line	GND	Live wire	Neutral line	GND
	Sectional area mm <sup>2</sup>	150	95	95	150	95	95
	Pieces	3	1	1	3	1	1
Unit connecting wire	Sectional area mm <sup>2</sup>	1.5 (shielded cable)			1.5 (shielded cable)		
	Pieces	2			2		

## 8. Electrical Parameter Table of Air-cooled Air Conditioning Unit ODU — Cooling-only Type

Model	ODU TSA	012*	020*	025*	030*	041*	052*	062*
Power supply	380V 3N~50Hz							
Power cord	Type	ODU	ODU	ODU	ODU	ODU	ODU	ODU
	Sectional area mm <sup>2</sup>	4	6	6	10	10	10	16
	Pieces	5	5	5	5	5	5	5
Unit connecting wire	Sectional area mm <sup>2</sup>	2.5*2+1.5*3	1.5	1.5	1.5	1.5	1.5	1.5
	Pieces	5	2	2	2	2	2	2

## ★ Remarks:

- The unit power cord must be a copper core cable, the operating temperature cannot exceed the defined value, and the recommended diameter is the specification selected when the ambient temperature of application is 40°C.
- If the power cord is longer than 15 m, increase the cross section of power cord properly to prevent accidents caused by overloading.
- The auxiliary electric heater is not considered for the recommended power cord diameter. If an auxiliary electric heater is selected for the unit, the copper core cable with the diameter meeting the national standard should be selected according to the power of auxiliary electric heater, lest an accident would take place. Meanwhile, when the actual installation conditions have been changed on the field, consider reducing the capacity according to the power cord and circuit breaker specifications provided by the manufacturer.

## Dimensions

TSAX008BR

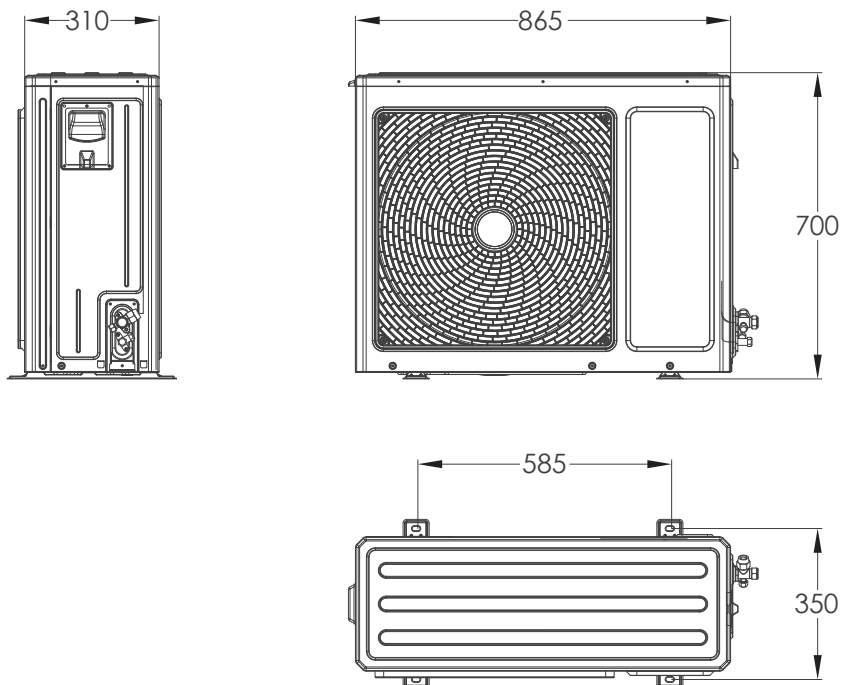

TSAX012B(R)2

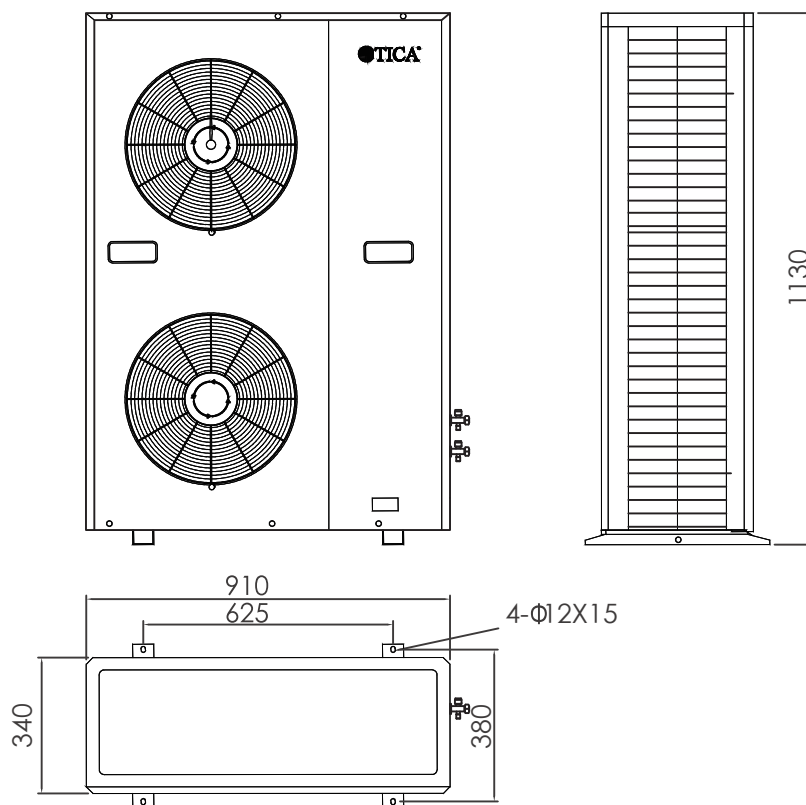





DX MODULAR AIR HANDLING UNIT

TSAX020、TSAX025、TSAX030、TSAX041、TSAX052、TSAX062

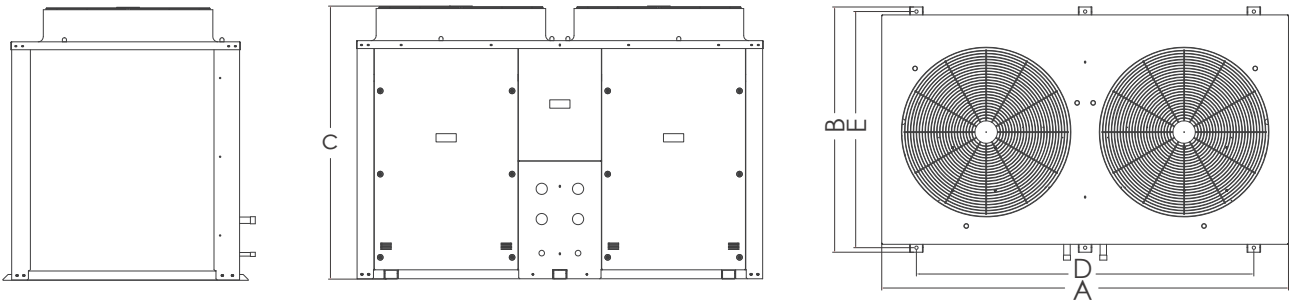

Model	A	B	C	D	E	Connection mode
TSAX020B(R)2	1403	821	966	763	790	Welding connection for IDU/pipe socket for ODU
TSAX025B(R)2			1200			
TSAX030B(R)2			1200			
TSAX041B(R)2	1403	821	1200	763	790	Welding
TSAX025C(R)	1403	821	1200	763	790	Pipe socket
TSAX030C(R)						
TSAX041C(R)						
TSAX052(R)2	1808	1090	1214	1500	1050	Welding
TSAX062(R)2						
TSAX052C(R)						
TSAX062C(R)						

TSAX290/330

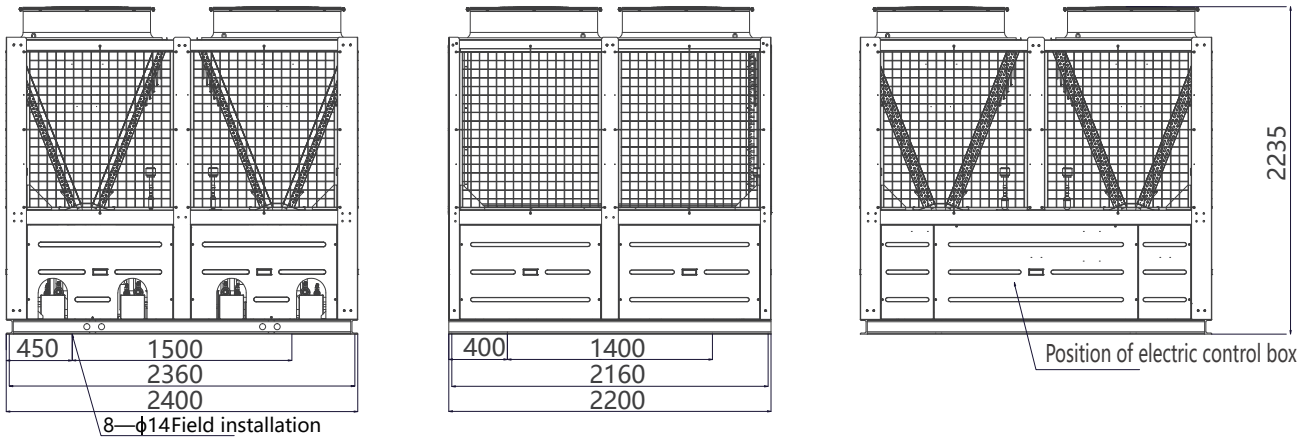

## Precautions for Unit Installation and Use

### Unit Installation

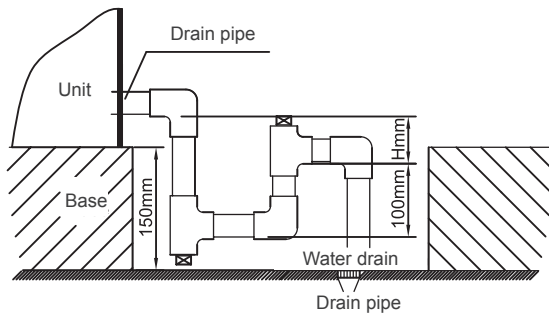

$H = \text{Unit inside static pressure (mmH}_2\text{O)} + 20$   
When the inside static pressure exceeds 750 Pa, increase the base height.

U-shaped water seal installation diagram

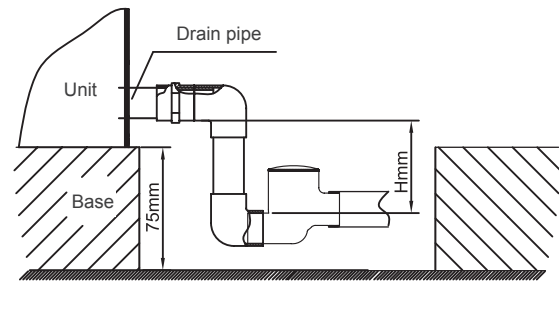

$H = \text{Unit inside static pressure (mmH}_2\text{O)} + 20$   
When the inside static pressure exceeds 750 Pa, increase the base height.

Floating ball-type water seal installation diagram

- The air conditioning units of all structure types should be installed on a horizontal base.
- A sufficient space should be reserved around the unit, especially at the access door side of unit pipes, fan and motor, so as to facilitate routine unit inspection and regular maintenance.
- A U-shaped drain pipe must be first connected at the condensate water outlet or a ball-type water seal must be installed before connecting to the external pipe.
- Exert balanced force when connecting the water inlet and outlet pipes of coil. Overexerting may damage the coil.
- The motor of air conditioning unit should be connected to a power supply with overload protection, and provide with grounding protection.
- Flexible connection should be adopted between the air conditioning unit and the external air duct to avoid vibration transmission;

### Precautions on IDU Use

- Before starting the unit each time, check all the valves of its water line and air duct, and make them in the normal operation state.
- Check connection, operating and transmission conditions of moving parts such as the fan and motor regularly, and adjust them in time.
- Clean the primary efficiency filter with clean water or cleaning agent according to the fouling degree. The cleaning frequency depends on the environment of application.
- Clean or replace the medium efficiency filter when its resistance rises to two times of the initial resistance.
- Make sure that the steam coil closes the steam valve before the fan stops.
- Make sure that the steam humidifier closes the steam valve before the fan stops.
- When the customer configures an electric control cabinet independently, the electric heater can be started only after the fan starts. It is advised to turn off the electric heater and close the steam valve 5 minutes before the fan stops. The overheat protection switch of electric heater needs to be connected to the electric heating control circuit.
- The three-phase five-wire system is adopted for the unit power cord. When the phase line diameter of electric heater is not greater than  $35 \text{ mm}^2$ , the null line diameter is the same as the phase line diameter; when the phase line diameter is greater than  $35 \text{ mm}^2$ , the null line diameter is 1/2 of the phase line diameter and cannot be smaller than  $35 \text{ mm}^2$ .



## Precautions for ODU Installation

- Make sure that the ODU installation location is far away from the site with flammable and explosive substances, heavy dust, concave, or high temperature.
- Make sure that there is a sufficient space around the unit to facilitate air inlet, air outlet and repair.
- Any obstacle will affect the cooling/heating capacity of the unit and will lead to inconvenience in the future repair and maintenance of the unit.
- For the maintenance space, refer to the figure below.

### Sufficient space for heat dissipation required for the ODU

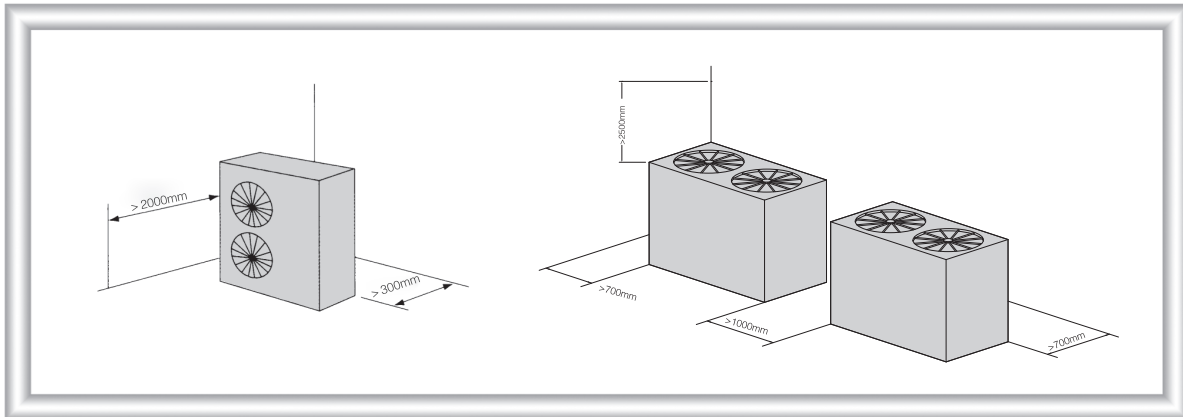

Oil return bends must be set on the gas pipe according to different IDU and ODU installation positions.

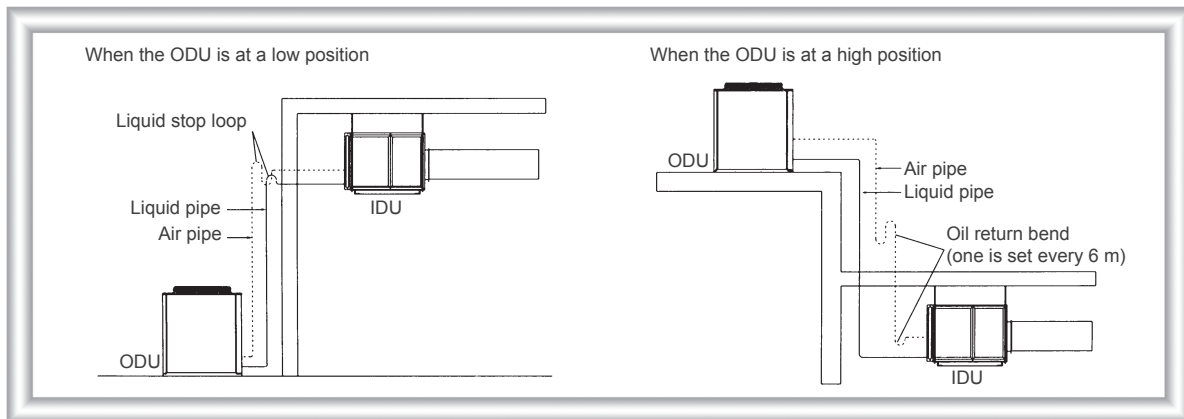

Short circuit should be avoided in IDU layout

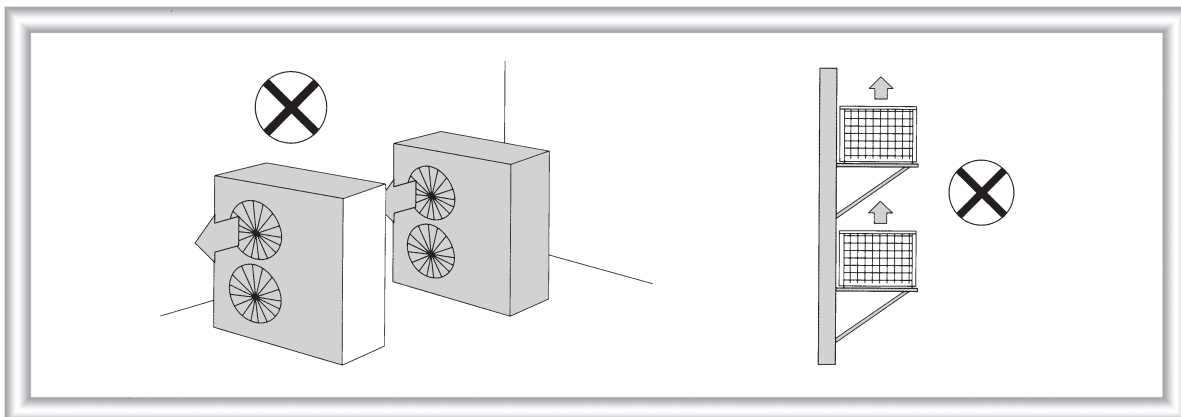

# Precautions for ODU Installation (TSAX290/330)

## 1. Installation Foundation Requirements

The unit can be directly placed on a base with drains reserved around. The base can be pre-casted using cement. The unit can be supported by a bracket made of angle steel, with shockproof rubber pads. It can be also placed on the ground or flat roof. The base surface must be flat and horizontal.

### Notes:

- The foundation is made of reinforced concrete or channel steel frame, and is capable of bearing the weight of no less than 500 kg/m<sup>2</sup>.
- Use rubber damping pads or shock absorbers with the thickness not smaller than 20 mm between the unit base and the foundation.
- Use M10 and M12 bolts to fasten the unit to the foundation.
- The foundation surface must be flat and horizontal and drains need to be reserved around the foundation.

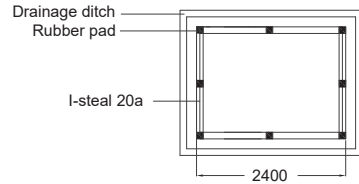
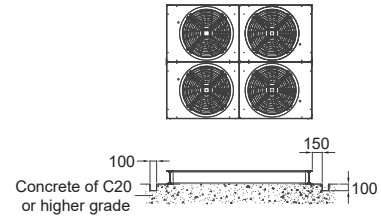

I. I-steel foundation diagram

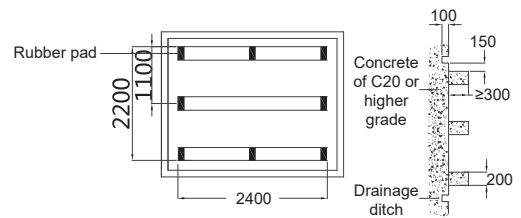

II. Concrete foundation diagram

## 2. Installation space requirements

The installation space of the unit must meet relevant dimension requirements for the ease of overhaul and maintenance.

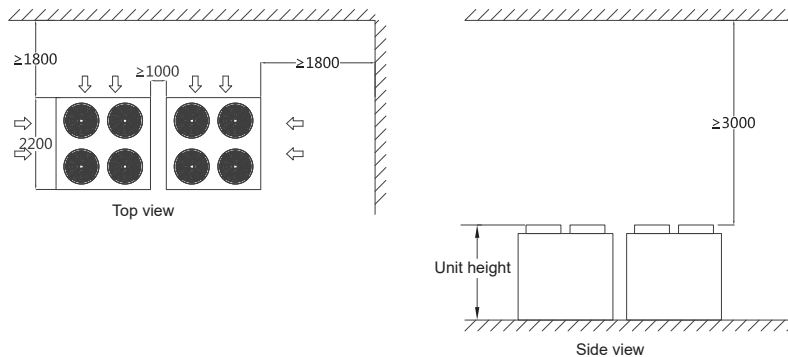

## 3. Monsoon protection requirements

For regions with strong monsoon, if the air-side heat exchanger is installed facing the direction of the monsoon, install the monsoon shield according to the following requirements to prevent the strong natural wind from affecting the air flow of the unit, and shield the heat exchanger from snow.

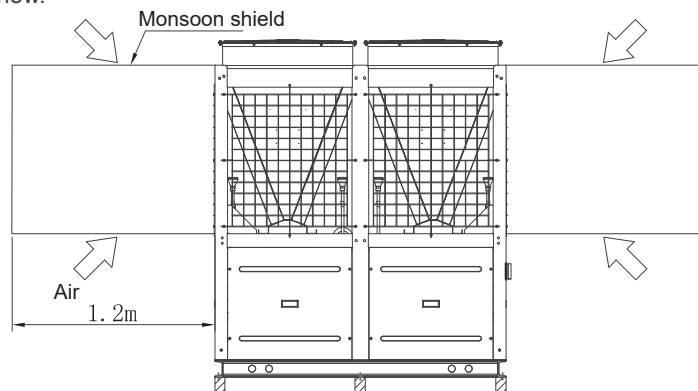





#### 4. Snow protection and anti-freezing measures in cold regions

It often snows in winter in some regions. Therefore, the air-side heat exchanger and air outlet of the unit should be protected against snow. At the same time, in the freezing and snowy regions, the installation height of the unit needs to be increased according to the snow amount or the thickness that makes it easy to freeze condensate.

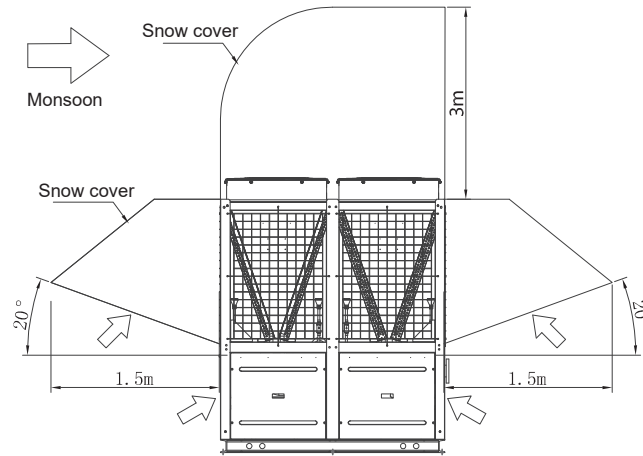

Snow cover installation diagram

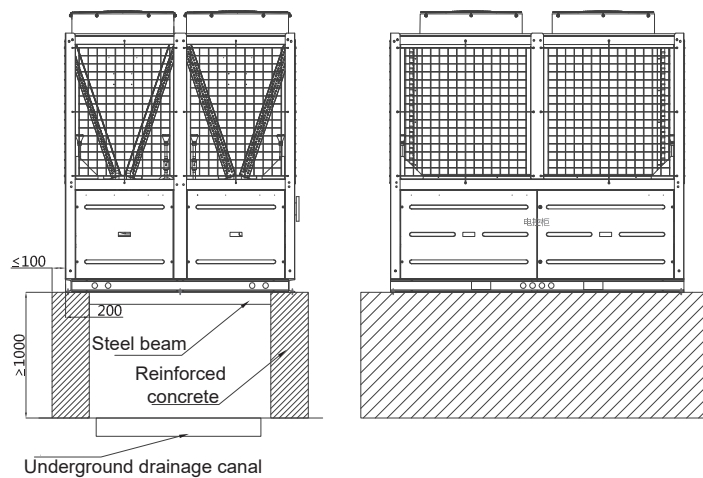

Installation diagram of accumulated snow-proof regions or cold regions which are prone to freeze

### IDU-ODU connecting requirements

Oil return bends must be set on the gas pipe or liquid stop loops must be set on the gas/liquid pipe according to different IDU and ODU installation positions

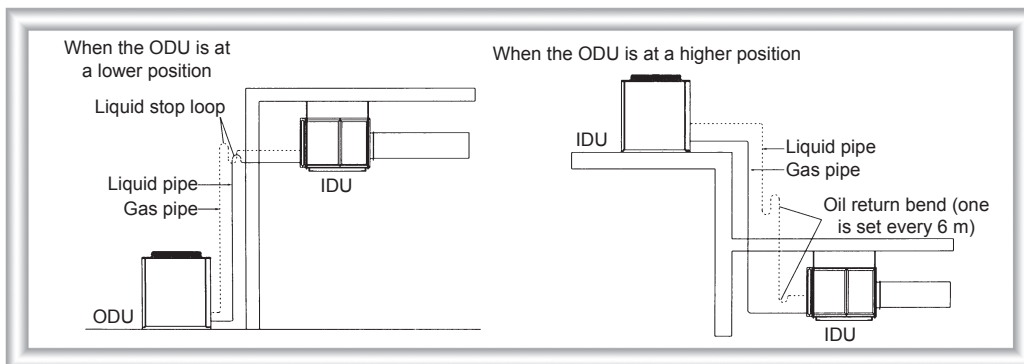

# Maintenance

## Routine Maintenance:

The air conditioning unit is a kind of equipment. The user is recommended to record the routine operating date of equipment and carryout regular maintenance.

### 1\Check the following items before putting the equipment into use:

- (1) Check whether all the power supply connections of indoor terminal equipment are correct and whether the fan operates normally.
- (2) Check whether all the air valves at the indoor terminal equipment inlets and outlets are opened.
- (3) Check whether the thermal insulation and condensate discharge measures of the pipeline system are proper.
- (4) Check whether all the power supply and control lines are connected in positions, whether the wires are connected correctly according to the wiring diagram, whether grounding is reliable, and whether all the connection terminals are fastened.
- (5) Check whether the ODU fan blades interfere with the fan guard net.
- (6) If the unit will be used again after stop for a long term, first connect the power supply for the unit for preheating for 12 h so that the outdoor compressor crankcase can be preheated.

### 2/ Routine maintenance during equipment use:

Unit maintenance items	Standard maintenance cycle			Remarks
	Monthly	Quarterly	Semiannually	
1. Check whether the power cord (from the power distribution cabinet to the unit entrance) is damaged or gets loose.			★	
2. Check whether the condensate drainage is normal.		★	●	Whether the pipes are installed according to the pipe connection diagram, whether they are blocked by dirt, whether drainage is smooth, whether overflow is caused, etc.
3. Check whether abnormal noises are sent out during operation of the unit.	★		●	Abnormal noises such as sharp metal friction sound, howling, significant thumping sound or resonance, significant electromagnetic noise and low-frequency edged sound (which may make people feel uncomfortable)
4. Check whether the air side of heat exchanger needs to be cleaned (surface dust, sundries, etc.).		★	●	Whether dust is accumulated between fins, whether sundries adhere to the air inlet side of coil, etc.
5. Check whether the air filter is blocked by dirt and whether it needs to be cleaned or replaced.	★	●		Whether the differential pressure alarm and differential pressure meter scale value reach the limit resistance value, etc.
6. Check whether the humidifying barrel of humidifier operates normally. Replace it in time in case of serious fouling.	★	●		

Special reminder: Routine maintenance cannot replace the specific requirements in the installation and use precautions in this repair and maintenance manual. In addition to routine maintenance, the installation and use precautions must be followed strictly to ensure normal operation and use of the product.

### 3\ The following maintenance methods are recommended when the equipment will not be used for a long term

- 1) When the unit will not be used for a long term or will stop in winter, turn off the power supply, and drain water from the water system and steam coil of the unit.
- 2) When the unit needs to be used again after shutdown for a long term, carry out comprehensive inspection to make sure that the unit is normal, connect the power supply to preheat the unit for more than 12 hours, and confirm that all aspects are normal before starting the unit.
- 3) If necessary, the maintenance methods before the equipment is put into use can be carried out.

Notes:

- (1) Maintenance by the user: Mandatory inspection item --- ●; Recommended inspection item --- ★
- (2) The user needs to buy wearing parts required during maintenance from TICA.
- (3) The maintenance methods are prepared for the cycle of normal use. For use under a malicious situation, make reasonable arrangement according to actual conditions.



Follow the Official Site  
of «TICA PRO» LLC

---

## TICA PRO LLC

Tel.: +7 495 127 79 00,  
+7 915 650 85 85,  
+7 969 190 85 85

E-mail: [info@tica.pro](mailto:info@tica.pro)

[www.tica.pro](http://www.tica.pro)

---

Note: Due to constant improvement and innovation of TICA's products, the product models, specifications and parameters contained in this document are subject to change without prior notice.