

INSTALLATION & OPERATION MANUAL

Installation & Operation Manual

AIR SOURCE HEAT PUMP WATER HEATER
(CIRCULATING)

Installation & Operation Manual

Contents

I. Must-read for Users	3
II. Appearance	4
III. Specifications	5
IV. Functions	6
1. System operating principles	6
2. Heating mode	6
3. Heating capacity	6
4. Power failure memory function	6
5. Grade four anti-freezing protection function	6
6. Automatic defrosting function	6
7. Auxiliary heat source	6
8. Variable operating condition curve	7
V. Installation Instructions	9
1. Selection of unit installation site	9
2. Unit installation space	9
3. Unit handling	11
4. Unit fixation	11
5. Pipeline connection	12
6. Pipeline selection	13
7. Water line insulation requirement	14
8. Model selection of water pump	15
9. Requirements for water tank model selection	15
10. Installation of water tank	16
11. Installation of water level switch	17
12. Water quality requirements	18
13. Electrical connection	19
14. Sequence number setting of heat pump unit	20
15. Trial operation	22
VI. Operation and Application of Wired Controller	23
1. Overview	23
2. Overall outline drawing of wired controller	24
3. Pattern display description	24
4. Button operation instructions	26
5. Wired controller operating instructions	27
VII. Servicing and Maintenance	32
VIII. Handling of Common Faults	34
IX. Appendix	39
1. Unit circuit diagram	39
2. Wiring diagram of single unit	40
3. Wiring diagram of multiple parallel units	40

I. Must-read for Users

Read the Installation & Operation Manual thoroughly before installing and using the equipment and keep it for future reference.

- Only professionals can install TICA air source heat pump water heater. TICA assumes no liabilities for the adverse effects or damages on the equipment or losses arising from improper operations, including but not limited to pipe leakage, electric leakage and improper installation, which may influence the normal operation and usability of equipment.
- Only units of the same model can be connected in parallel.
- Reserve enough space for equipment installation strictly in accordance with the Manual. Otherwise, the heating effect may be compromised.
- Each heat pump unit is equipped with a circuit breaker, which is used to cut off the power supply during maintenance. Users need to install a residual current device between the power supply and the unit.
- Do not install the unit and the hot water tank in lightning-prone places. Be sure to take surge protection measures.
- When the equipment is available for commissioning upon installation, call TICA's hotline to request equipment commissioning service. The equipment is usable only after a commissioning test is done. TICA assumes no liabilities for any losses arising from unauthorized access to the equipment.
- Once the equipment has been installed and placed in operation, users shall regularly check and maintain the equipment based on usage. In case of an abnormality, stop using it immediately and call TICA's hotline to report such event.
- Do not put your fingers or other objects into a running unit as the fan operating at a high speed may cause injuries.
- The equipment may cause severe scalding injuries. Ensure proper mix of hot and cold water before use.
- Any part that is soaked in water can be used again only after it is inspected or repaired by a professional.
- The water discharged from the equipment (including the water heated at high temperature) is not drinkable.
- Use a dedicated branch circuit for circuit connection of the equipment. Contact a qualified electrician to check the electricity meter, circuit breaker and wire diameter to make sure that they meet the maximum operating current requirement.
- If the equipment is disused for a long period of time, cut off the power and empty the equipment and the pipeline to prevent freezing.
- TICA assumes no liabilities for any losses arising from commissioning, maintenance or servicing by unauthorized personnel or from using the equipment other than the purposes contained within this Manual.
- If the power cord is damaged, to avoid dangers, make sure to ask a professional from the manufacturer or its maintenance department or similar department to replace it.
- Nanjing TICA Climate Solutions Co., Ltd. reserves the right to interpret this Manual.

Caution: Failure to observe this Manual may cause fire, losses, personal injury or even be fatal.

Warning: The power supply of this equipment must be reliably grounded before use. Within close proximity of the air source heat pump water heater, there must be a well-functioning floor drain. In addition, water leakage of the unit or from the joints in the unit installation area shall not do any harm to adjacent items or the bottom floor of the building.

II. Appearance

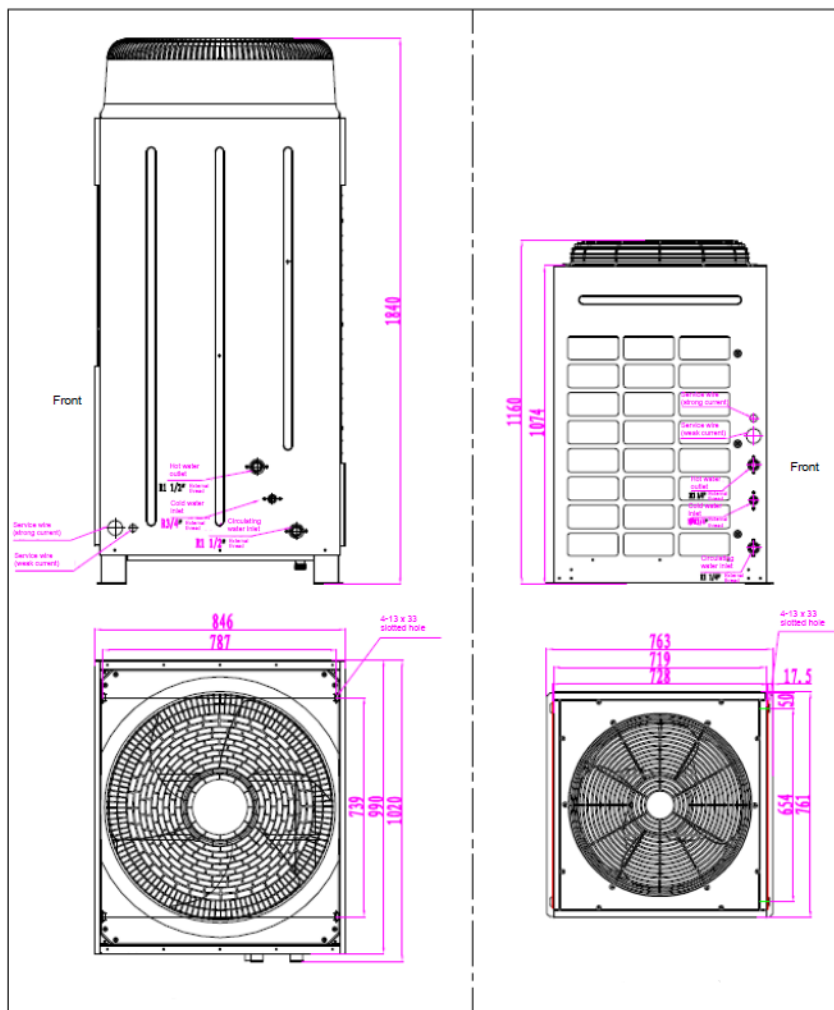

TCAH100FC

TCAH50FC

Figure 2.1 Dimensions

Dimensions

Model	TCAH100FC	TCAH50FC
Unit Dimensions	1020×846×1840mm	763×761×1160mm
Package Dimensions	1150×920×2045mm	926×869×1360mm

III. Specifications

Standards: **GB/T 21362, GB 29541**

Model	TCAH100FC	TCAH50FC
Nominal heating capacity (kW)	38.5	18.6
Rated power input (kW)	8.75	4.24
COP (W/W)	4.40	4.39
Nominal water output (L/h)	828	400
Rated water flow(m ³ /h)	6.6	3.2
Water resistance (kPa)	50	60
Power Supply	380V 3N~50Hz	380V 3N~50Hz
Maximum total power (kW)	13.2	6.8
Operating voltage range	380±10%	380±10%
Maximum total power (kW)	13.2	6.8
Maximum operating current (A)	23.3	11.7
Applicable ambient temperature (°C)	-10 - 48	-10 - 48
Sound level (dB(A))	65	60
Maximum permissible pressure on high pressure side (MPa)	4.4	4.4
Maximum permissible pressure on low pressure side (MPa)	3.1	3.1
Maximum bearing pressure in water system (MPa)	1.0	1.0
Refrigerant/Charge quantity	R410A/4.8 kg	R410A/2.4kg
Waterproof standard	IPX4, and applies to outdoor applications	IPX4, and applies to outdoor applications
Protection class	Class I	Class I
Climate type	Ordinary	Ordinary
Hot water outlet pipe diameter (External thread)	DN40 (R1 1/2")	DN32 (R1 1/4")
Circulating water inlet pipe diameter (External thread)	DN40 (R1 1/2")	DN32 (R1 1/4")
Net weight (kg)	287	170
Gross weight (kg)	310	195

Note:

1. The unit performance parameters are tested in the following conditions: ambient DB/WB temperature is 20°C/15°C, water inlet temperature is 15°C, and water outlet temperature is 55°C;
2. The unit circulating water side pressure is tested in the condition of rated circulating water side flow;
3. Due to product improvement, the product models, parameters and performance are subject to changes without prior notice. The parameters indicated on the nameplate should prevail.
4. Please refer to the maximum total power and maximum operating current during unit power distribution.

IV. Functions

1. System operating principles

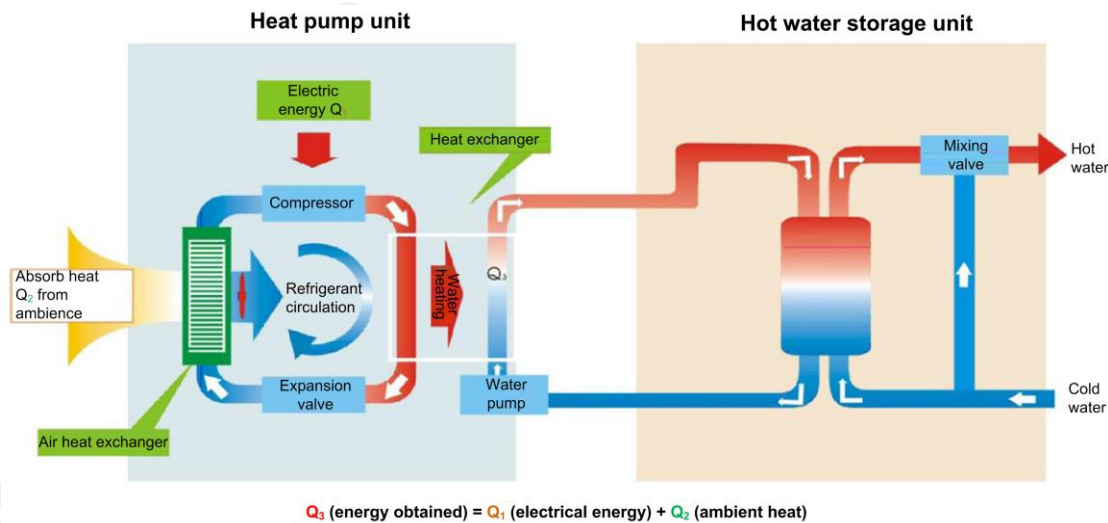

2. Heating mode

TICA circulating type air-source heat pump hot water unit can heat the circulating water in the tank to the user-defined water leaving temperature through the efficient double type heat exchanger.

3. Heating capacity

The air source heat pump water heater heats the circulating water in the water tank by absorbing the heat in the air, and giving out heat in the heat exchanger through compressor working. Therefore, the heating capacity is closely related to the ambient temperature and water temperature in the tank. When the ambient temperature decreases, the heating capacity of the unit will be attenuated. Similarly, the change of water temperature in the tank will also influence the heating capacity of the unit.

4. Power failure memory function

The wired controller can automatically store the unit status (ON/OFF) each time before the air source heat pump water heater is powered off. When the unit is powered on again, the wired controller sends power-on/off signal to the unit according to the stored status before power-off, to ensure that the unit could operate as previously set.

5. Grade four anti-freezing protection function

At low ambient temperatures, in particular, when the ambient temperature is below 0°C , the water system of the air source heat pump water heater will most likely fail to work properly due to frozen water pipes. By utilizing TICA's unique grade four anti-freezing technology, our air source heat pump water heater could determine when to enter or exit anti-freezing protection depending on the ambient conditions, and therefore guarantee steady operation of the unit to the greatest extent.

6. Automatic defrosting function

In conditions with low ambient temperature and high relative humidity, the heating capability and water production of air source heat pump water heater will decrease with the accumulation of frost on the surface of the fin. The TICA air source heat pump water heater can achieve fast automatic defrosting through the unit control system. And the unit operation rate can reach more than 90%.

7. Auxiliary heat source

The heating capacity of the air source heat pump water heater will be attenuated as the ambient

CIRCULATING AIR SOURCE HEAT PUMP

temperature decreases. In places where the ambient temperature in winter may be below 10°C, an auxiliary heat source that could provide certain heating capacity shall be equipped to improve the heating capacity of the system and ensure that the system can supply hot water properly and reliably.

Regardless of the auxiliary heat source used, the unit provides one control signal that tells the peripheral equipment to turn the auxiliary heat source on or off. The auxiliary heat source requires additional independent control and separate configuration of the corresponding safety protection functions.

8. Variable operating condition curve

8.1 TCAH50FC variable operating condition curve

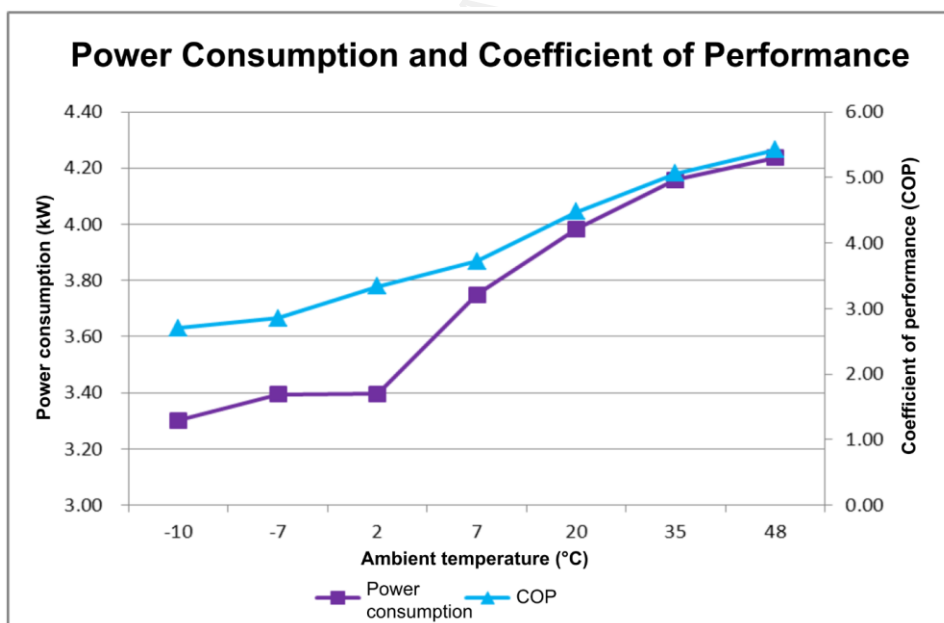
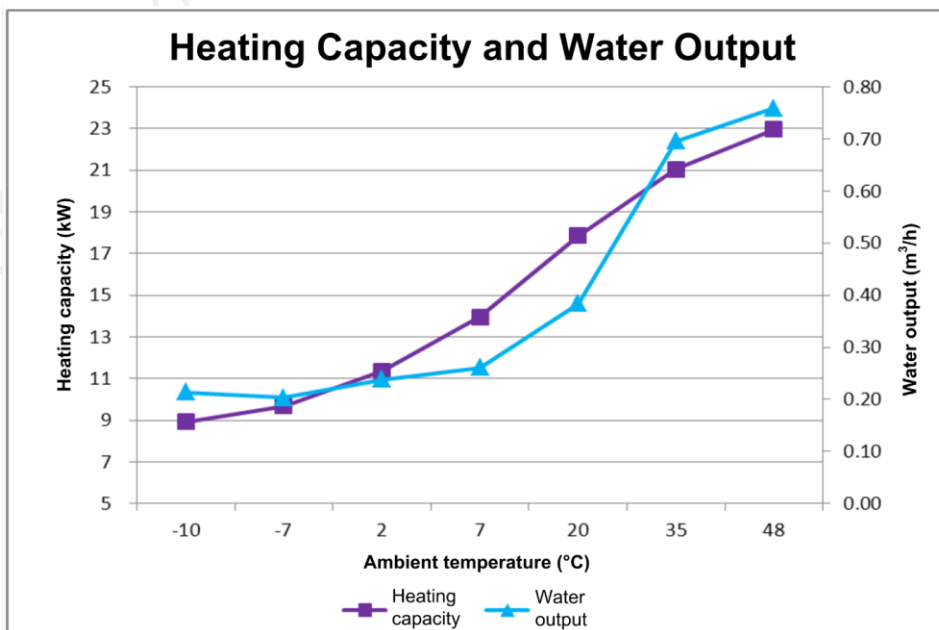

CIRCULATING AIR SOURCE HEAT PUMP

8.2 TCAH100FC variable operating condition curve

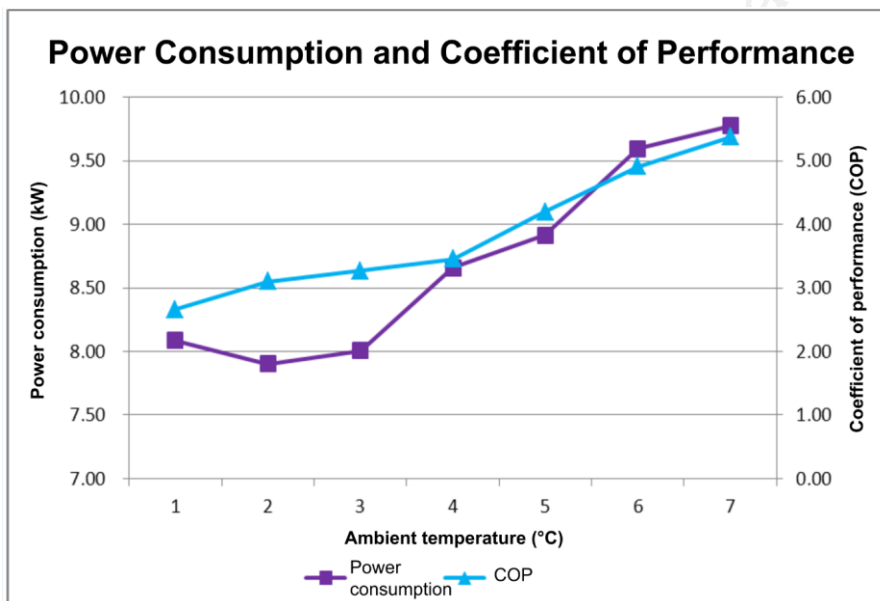
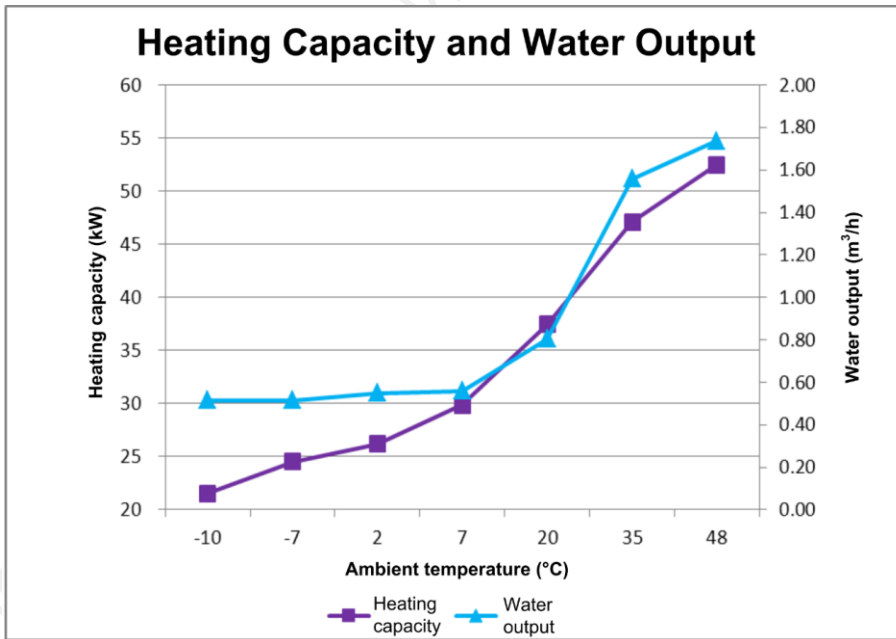

V. Installation Instructions

Notes:* Upon receiving the unit, check whether the unit model is correct, accessories complete and the appearances of the unit intact. If you find any damages or you have other problems, please immediately call your salesman.

* Before installation, make sure that the unit power is consistent with its electricity meter capacity and power cords.

* The unit must be reliably grounded. Never connect the earth line to the neutral line or to the water pipe.

1. Selection of unit installation site

When installing the unit, note that:

- The unit can be installed on the ground or on the strong enough roof with sufficient installation and maintenance spaces reserved.
- The air outlet and inlet of unit are unimpeded to ensure enough air flow for heat exchanging; in the meantime, prevent the cold air generated by the unit from affecting its surroundings.
- Avoid installation of unit on a noise- or vibration-sensitive place, lest it may disturb the residents within its proximity.
- The shock absorbing device must be equipped on the unit to prevent vibration from spreading over the building.
- The unit shall be installed far away from the place influenced directly by heavy current and high magnetic field.
- Choose a well drained place to install the unit, to make sure that no water accumulates.
- If installed in a place where people have easy access to the unit, adopt safety measures, such as fences, to avoid man-made or accidental damages.
- The unit cannot be installed in the atmospheric environment containing oil (including machine oil), salt (marine area), or sulfide gas (the neighborhood of hot spring or oil refinery), or other corrosive gases, because these substances may easily cause unit failures.

2. Unit installation space

- Install the unit after the servicing space shown in following figure is reserved.
- There are two installation methods when there are multiple units. Please select a suitable installation method according to the site conditions.

CIRCULATING AIR SOURCE HEAT PUMP

1) Arrange in a vertical and side-by-side manner, as shown in Figure 5.1.

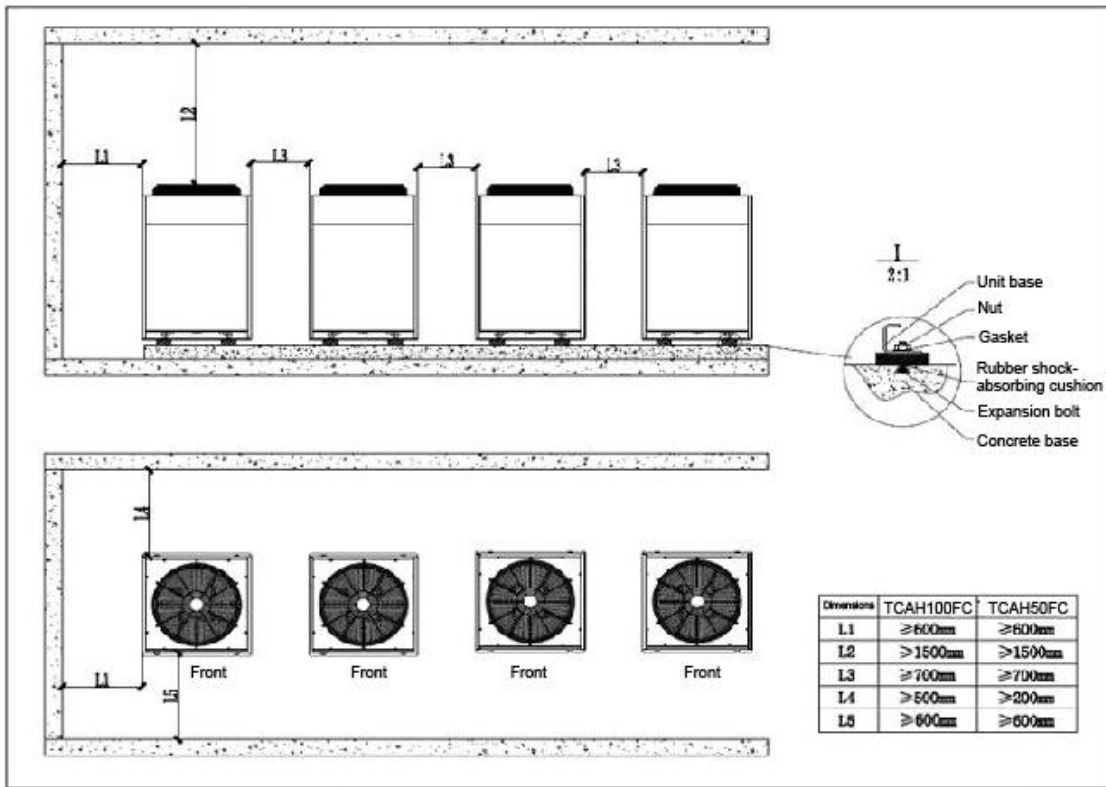

Figure 5.1 Vertical and side-by-side arrangement

2) Arrange in a horizontal and side-by-side manner, as shown in Figure 5.2.

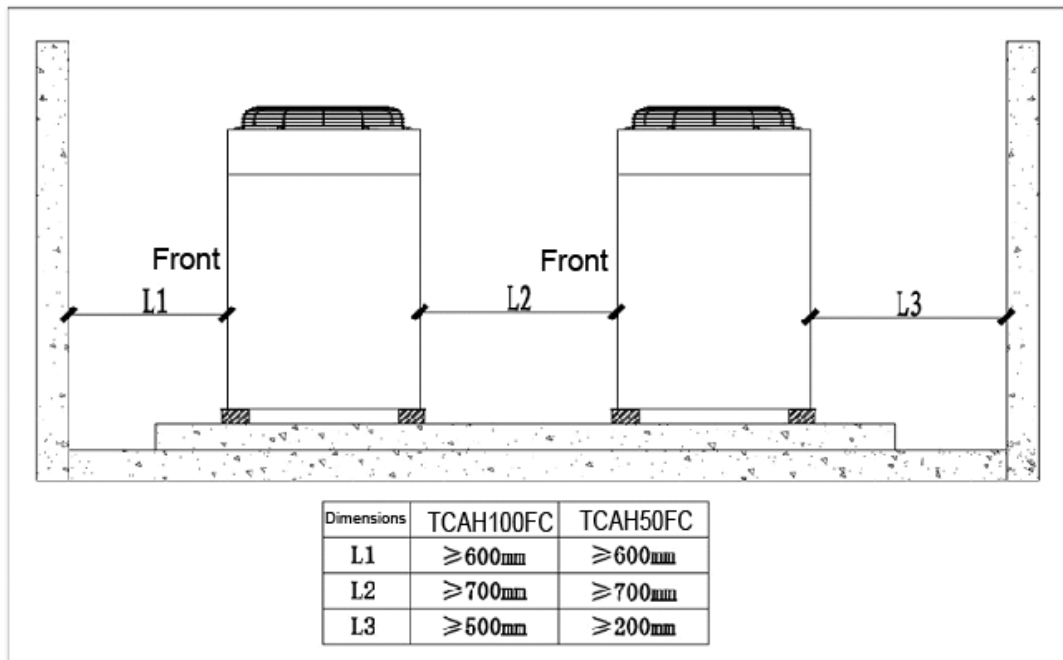

Figure 5.2 Horizontal and side-by-side arrangement

- If the unit is installed in the basement, room or other poor-ventilated areas, the required air circulation volume shall be satisfied: for TCAH100FC, the air circulation volume for each unit

CIRCULATING AIR SOURCE HEAT PUMP

shall not be less than 13,000 m³/h; for TCAH50FC, the air circulation volume shall not be less than 7000 m³/h.

- The height from the unit bottom to the ground or floor shall be greater than the local maximum snow depth and the possible water depth.

3. Unit handling

- Use forklift or crane or sling to handle units. Unless there is exceptional circumstance, unpack the unit only after it is in place.
- When you handle the unit, keep the unit balanced as much as possible. In any case, the maximum inclination of unit cannot exceed 30 degrees to protect the compressor against damage. If hoisting method is adopted, check the sling strength and balance before hoisting. The sling shall be able to bear six times the unit weight.
- During the handling, never allow the heat sink of unit to come in contact with any object.
- After handling, unpack the unit, including removing the wooden subplate.
- If the outer packaging has been removed before handling, in order to avoid surface scratch and deformation during handling, add a protective plate at the unit surface contacting with the steel wire.

4. Unit fixation

Before installing the unit, prepare the mounting base and keep it in a level condition. The base can be made of reinforced concrete or steel bracket. After the base is prepared, fix the bolts on the base. Be sure to install the rubber shock absorber on the bolts to mitigate vibration transmission and noise. Finally, put the unit in place and lock the unit, rubber shock absorber and base.

If the unit is installed at the roof and used in the place which poses a severe requirement on the vibration and noise, **double-layer shock absorber** is recommended. It can be achieved by adding one steel bracket on the original reinforced concrete foundation or steel bracket and then adding one layer of vibration-absorbing pad between the original foundation and added steel bracket.

5. Pipeline connection

Notes:

- To ensure water resistance balance, a direct return water system is required when multiple units are installed in parallel.
- A hot water unit can be connected to the water inlet and outlet pipes only after it is properly installed.
- Water filter must be configured at the water inlets of the circulating pump. The installation position should ensure convenient disassemble and cleaning.
- To ensure the effectiveness of the use of hot water and normal operation of the unit, the inlet and outlet pipes must be properly insulated.
- Keep pipes of the system clean and away from pollutants to prevent dusts or other sundries from entering the pipe system during installation.
- If the tap water pressure cannot meet the water pressure requirement of unit, a cold water storage tank should be provided to ensure constant-pressure water supply.
- The provided water filter can be directly installed at the male adaptor of the inlet. Pay attention to the installation direction and the facing direction of filter.
- Should install the automatic air discharge valve in the system, for air could affect the monitoring results of flow,

Each system of TICA air source heat pump water heater can connect up to 16 heat pump units in parallel. Fig. 5.3 is suitable for timing water use. Firstly, the water temperature is heated to a set temperature, and then the water is recharged after use. Fig. 5.4 is suitable for irregular water use. After heating the water in the heating water tank to a set temperature, it is injected into the water storage tank for reserve. Among them, water level switch is used for water replenishment of water tank in automatic control system. The unit is not standard when it leaves the factory. Customers can choose and match according to their needs. The unit provides the control signal of the auxiliary heat source to inform the peripheral equipment that the auxiliary heat source can be turned on and off. Auxiliary heat sources need to be controlled independently and equipped with corresponding safety protection functions separately.

CIRCULATING AIR SOURCE HEAT PUMP

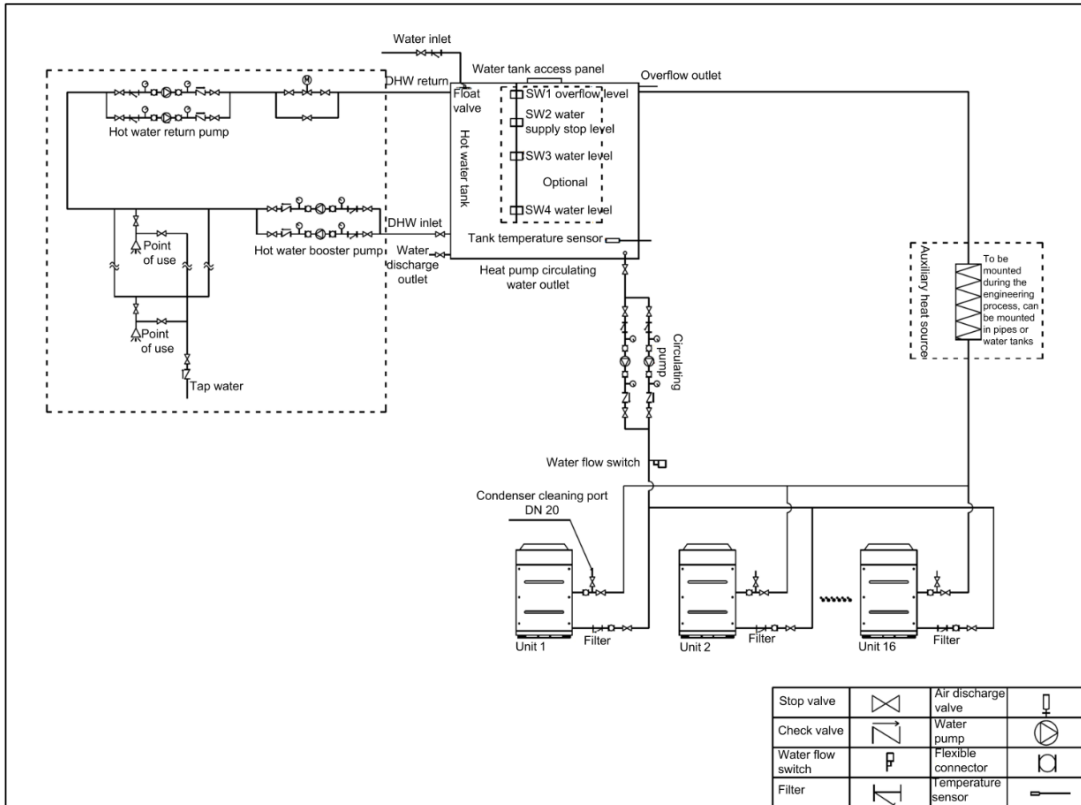

Figure 5.3 Air-source heat pump hot water system(for timing water use)

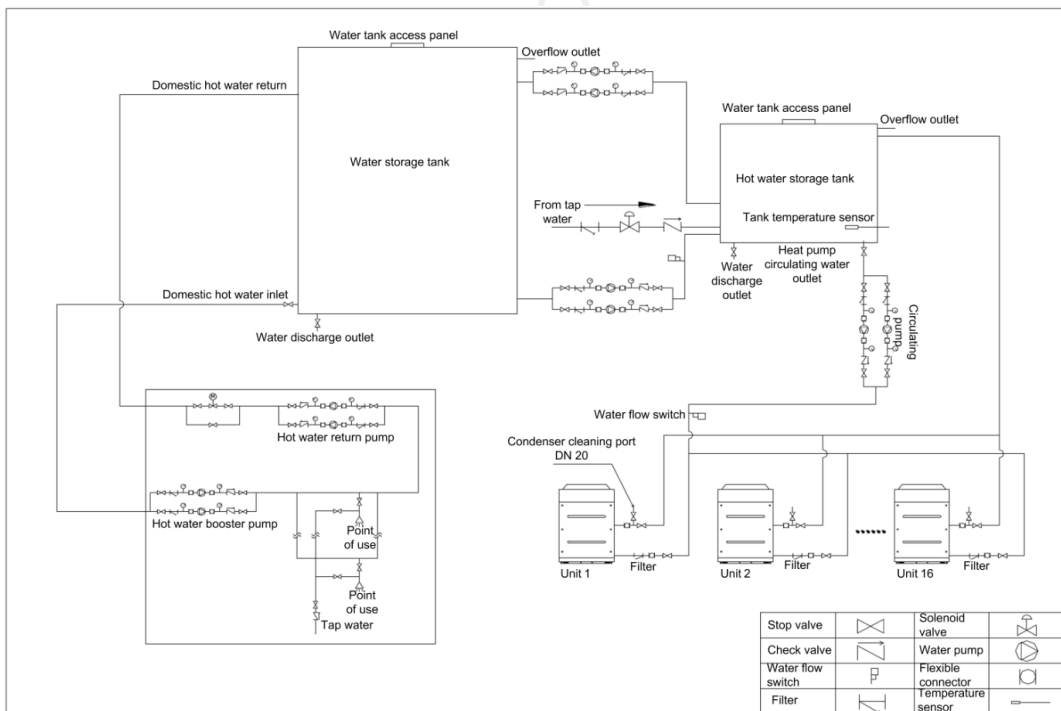

Figure 5.4 Air-source heat pump hot water system(for unscheduled water use)

6. Pipeline selection

When multiple units are connected in parallel, it is recommended to select the main water inlet pipe, main water outlet pipe diameters according to Table 5.1.

CIRCULATING AIR SOURCE HEAT PUMP

Table 5.1 Main water inlet & outlet pipe

Number of Units in Parallel	Main Water Inlet Pipe		Main Water Outlet Pipe	
	TCAH100FC	TCAH50FC	TCAH100FC	TCAH50FC
1	DN40	DN32	DN40	DN32
2	DN65	DN50	DN65	DN50
3	DN80	DN65	DN80	DN65
4~5	DN100	DN80	DN100	DN80
6~8	DN125	DN100	DN125	DN100
9~12	DN150	DN125	DN150	DN125
13~16	DN175	DN150	DN175	DN150

Notes: 1. A balanced water flow design needs to be adopted for the water inlet pipe and water outlet pipe.

2. If PP-R pipe is selected, the outer diameter of pipe shall be one size larger than values in the table.

3. Customers need to equip the circulating water inlet filters by themselves: for TCAH50/100FC, 16 to 20 meshes are recommended.

The auxiliary heater circulating pipe size is selected according to customers' demands for auxiliary heating; the domestic hot water supply pipeline is selected according to the actual water requirements on site. The flow rate of water in hot water pipe shall be selected according to Table 5.2.

Table 5.2 Flow rate of water in hot water pipe

Nominal Diameter (DN)	15-20	25-40	≥ 50
Flow Rate (m/s)	≤0.8	≤1.0	≤1.2

The water return pipe diameter of hot water supply system shall be determined through hydraulic computation according to the circulating flow of pipe, which can be determined according to Table 5.3 during preliminary design.

Table 5.3 Water return pipe diameter of hot water system

Hot water supply pipe diameter (mm)	20-25	32	40	50	65	80	100	125	150	200
Hot water return pipe diameter (mm)	20	20	25	32	40	40	50	65	80	100

7. Water line insulation requirement

It is advised to insulate all the hot water pipes with rubber and plastic material. The insulating layer shall have a thickness no less than 20mm (if other materials are applied, make sure that they are not inferior to the recommended material). In addition, for the hot water pipes outdoors, note to wrap their insulating layer with a protective layer which is galvanic sheet or aluminum sheet. When the ambient temperature is below 0°C, take corresponding insulation measures to prevent the cold water pipe rupture due to freezing. See Table 5.4 for the recommended thickness of rubber and plastic insulating layer for hot water pipe.

Table 5.4 Thickness of rubber and plastic insulating layer for hot water pipe

Diameter of hot water supply and return pipes (mm)	15~20	25~50	65~100	> 100
--	-------	-------	--------	-------

CIRCULATING AIR SOURCE HEAT PUMP

Insulating layer thickness (mm)	20	30	40	50
---------------------------------	----	----	----	----

8. Model selection of water pump

There is the circulating pump for the unit, and the water pump model selection shall satisfy requirements in the following table.

Table 5.5 Water pump model selection requirements for hot water system

Types of Water Pump	Water Flow		Pressure Drop at Water Side of Unit (kPa)		Remarks
	TCAH100FC	TCAH50FC	TCAH100FC	TCAH50FC	
Circulating pump	6.6m ³ /h× Quantity of heat pumps	3.2m ³ /h× Quantity of heat pumps	60	50	Hot water pump

- Notes: 1. The pressure drop at the unit water side in the table refers to the unit pressure drop and the press loss outside the unit shall be determined according to the actual situations.
 2. The actual water flow of unit shall not be less than 95% of the calculated value in the table.
 3. The water pump must be started and stopped by the unit. The unit only provides the control signal of the pump, and the power supply of the pump can not be directly connected to the control box of the unit.

9. Requirements for water tank model selection

- The water tank shall be insulated. See connector requirements in Figure 5.8. The diameter of the opening for installing the water level switch ϕ must be larger than 45 mm and smaller than 55 mm. If the opening is too large, the switch cannot be fixed; if the opening is too small, the switch cannot be laid in the water tank.

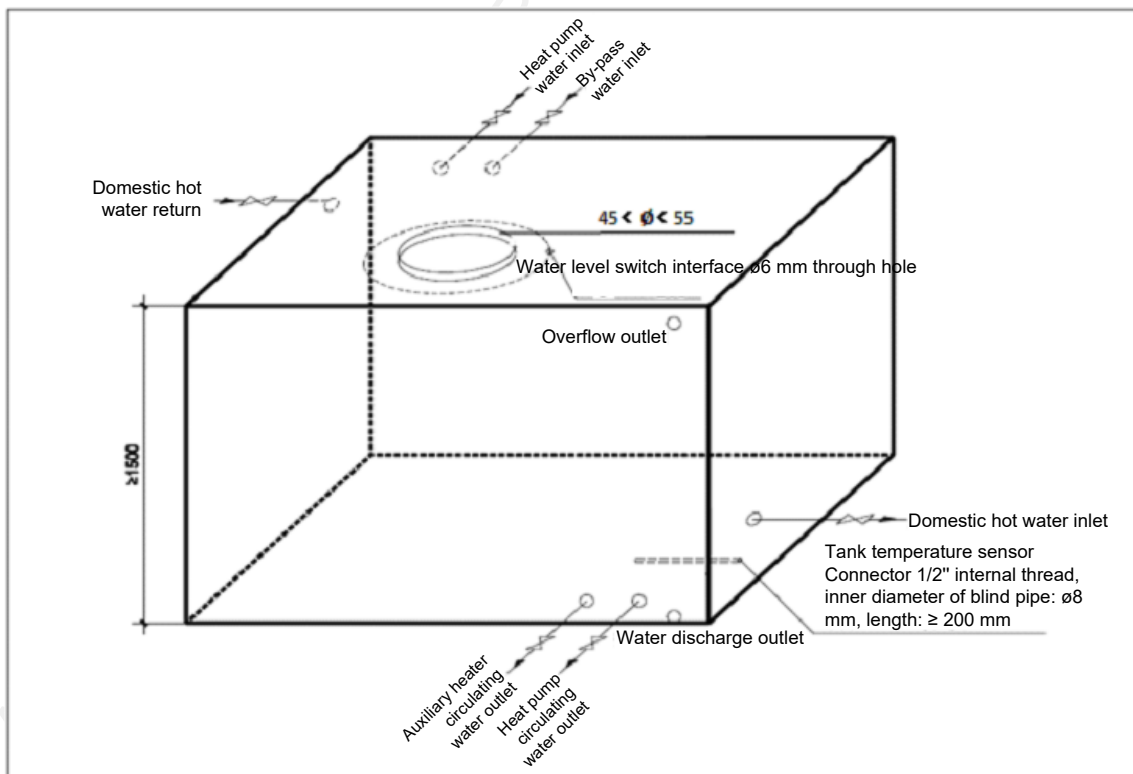

Figure 5.8 Schematic diagram of water tank connector

See Figure 5.9 for the local view of water inlet, tank temperature sensor connector, and blind pipe

CIRCULATING AIR SOURCE HEAT PUMP

size of tank temperature sensor.

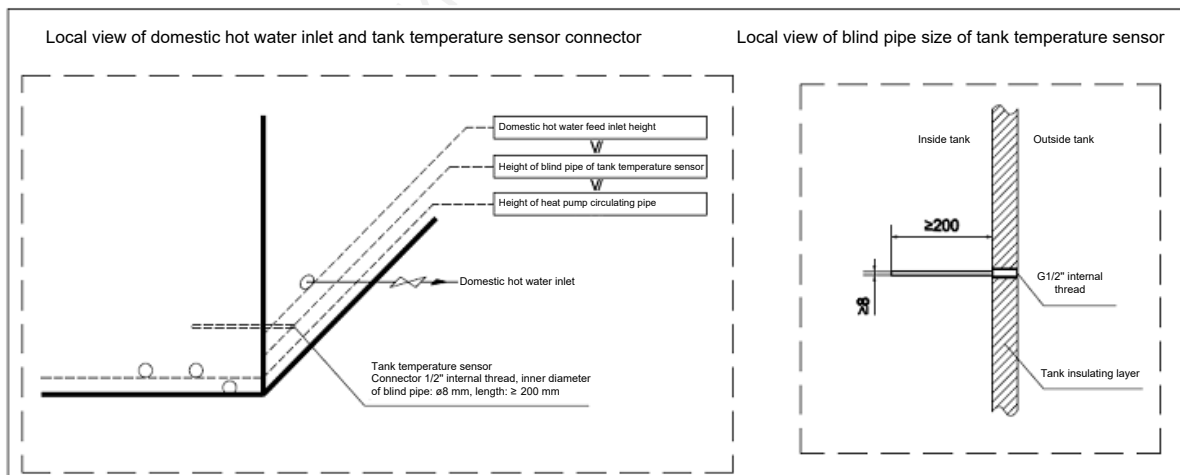

Figure 5.9 Local view of tank connector sizes

Notes:

- The size indicated in the diagrams is the net size from pipe to the inside tank, with the thickness of tank insulating layer excluded.
- The height of water tank needs to be ≥ 1.5 m, for the convenience to install the matched water level switch.
- The positions of the heat pump circulating water outlet and auxiliary heater circulating water outlet should be above the water discharge outlet but below the domestic hot water inlet. The height of the tank temperature sensor connector should be between the domestic hot water inlet and the heat pump circulating water outlet.
- The hot water inlet, domestic hot water return and by-pass water inlet should be arranged diagonally towards the domestic hot water inlet, heat pump circulating water outlet and auxiliary heater circulating water outlet. Positions of all the water pipes are determined according to the site conditions.
- The installation position of water level switch shall be close to the tank access port for the convenience of overhaul, and shall be away from the water inlet of water tank to avoid shock from water entrance. Ensure that the tank access port is covered lest foreign matters or rain enter.
- The water height controlled by the float valve connected to by-pass water inlet should be lower than the overflow outlet.
- Leakage detection should be carried out after completing the tank.
- The installation of water tank temperature sensor must ensure that it can accurately detect the tank temperature. And for a good contact between water temperature sensor and blind pipe, it is recommended to add the thermal conductive silicone.

10. Installation of water tank

Notes: ● It is recommended to install the tank as close as possible to the heat pump unit as long as the air circulation around the heat pump unit is ensured, which can reduce heat losses of pipelines.

- The open water storage tank installed cannot block the vent hole of the water tank.
- Recommend to install the auxiliary heater (if any) below the tank. If the e-heater is installed in the tank, it is recommended to keep the installation height of the e-heater lower than the domestic hot water inlet, so as to prevent the heating of e-heater without water.

The installation positions of water tank and unit are recommended as follows:

Install as shown in Figure 5.10 (the hot water storage tank is installed at the same height as the heat pump unit).

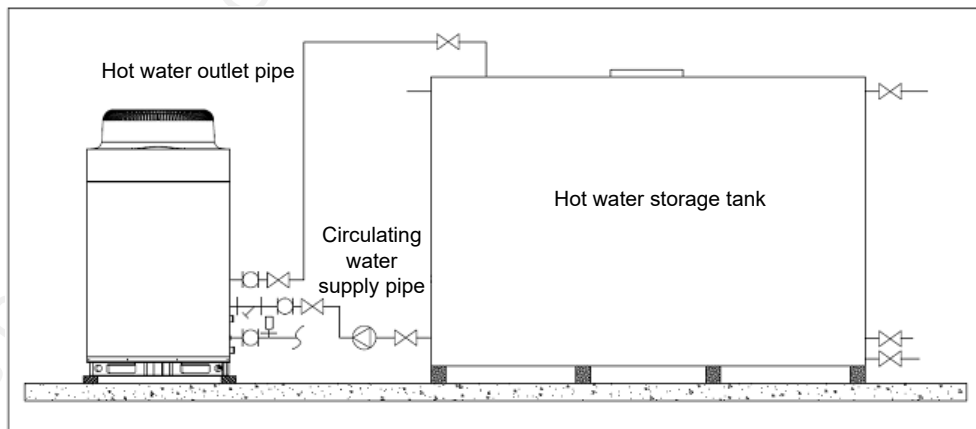

Figure 5.10 Hot water storage tank installed at the same height as heat pump unit

11. Installation of water level switch

The heat pump unit is equipped with standard water level switch before delivery:

During the installation of water level switch, thread its connecting wire and bolts at the fixed parts through the water tank and then tap the stainless steel self-tapping screws into the water tank body via the flange hole of water level switch (three $\phi 6\text{mm}$ holes) and fix the switch onto the outer wall of water tank. The built-in silicon flat pad at the flange bottom is water-proof and shock-proof, as shown in Figure 5.11.

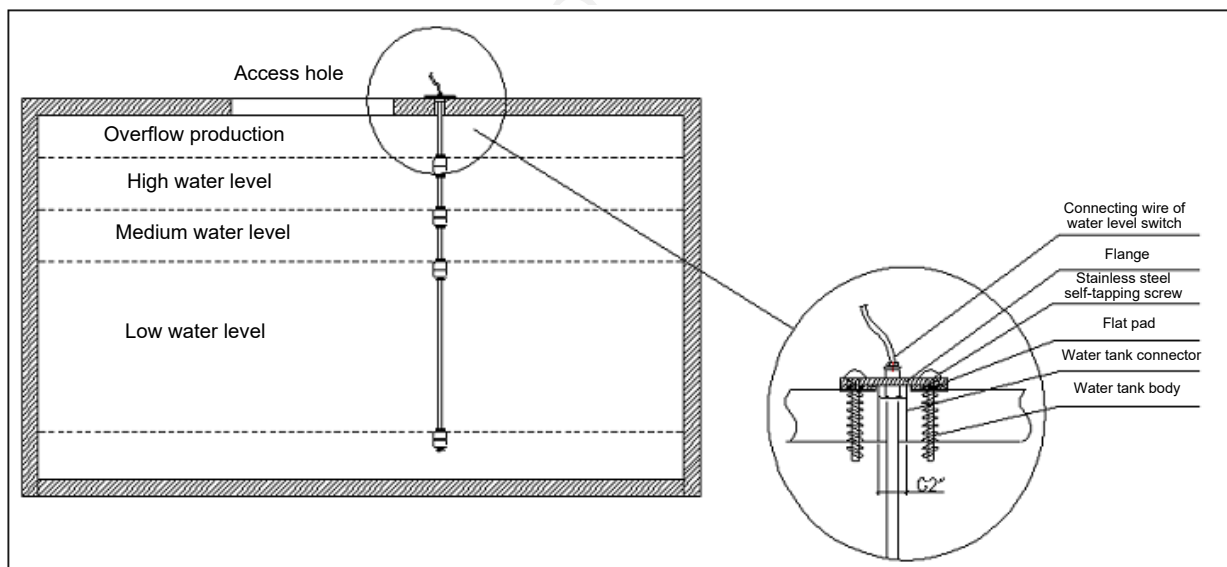

Figure 5.11 Installation methods of water level switch

Notes:

- The water level switch can only be used to control the start and stop logic of unit and may not display the actual water level of the water tank.
- Avoid hitting the water level switch. When the product is dropped from a height of 1.2 m or a higher place, it may be damaged. The installation position of water level switch shall be close to the tank access port for the convenience of overhaul, and shall be away from the water inlet side of water tank to avoid shock from water entrance.
- After the water level switch is installed, check whether the water level switch (high and low water level) wiring is correct and whether it can operate normally.
- Do not put the water level switch wiring directly in the water tank; otherwise, it may lead to wrong judgment of water tank level.
- The water level switch must be installed vertically as inclined installation may cause inaccurate measurement of water tank level.
- The water level switch cannot be fixed by pulling its own wire harness.

12. Water quality requirements

The water pumped into the unit must comply with the existing Sanitary Standard for Drinking Water. It is recommended to use water with low hardness, preferably the softened water. Never use water from seas, rivers or lakes or water directly from underground without treatment as it may damage the precision parts of the unit. The unit cannot be directly used for swimming pool heating.

CIRCULATING AIR SOURCE HEAT PUMP

13. Electrical connection**Notes:**

- The water heater unit shall use the special power supply whose voltage complies with the rated voltage.
- The power supply circuit of the water heater unit must have a grounding wire, and the power supply ground wire must be reliably connected with the valid external earth wire. Types of cables, layout and protective methods shall comply with electrical standard and requirements.
- Install the unit according to the national standard on wiring.
- Wiring construction must be carried out by professionals in accordance with the circuit diagram.
- Set an electric leakage protection device according to requirements of the related national technical standard of electrical equipment.
- The power cord and signal cable should be laid neatly and reasonably without interfering with each other, and cannot come into contact with the connection pipe and valve body.
- Power cord is not attached to this unit when delivered. Note to select the proper power cord. Power cord conversion is prohibited.
- When the power cord is parallel with control signal cable, put them into separate conduits with proper spacing reserved.

* After all the lines are connected, check them carefully for any errors before connecting the power supply.

(1) Power cord**Warnings:**

- For safety considerations, the circuit breaker and ground fault circuit interrupter must be equipped at the outside part of air source heat pump water heater according to the power supply specifications.
- The water heater must be grounded permanently. Otherwise, it may result in electric shock and serious personal injuries.

See Table 5.6 for the power supply wiring specifications of heat pump unit.

Table 5.6 Power supply wiring requirements for hot water system

Unit Model	Power Supply	Cable diameter (mm ²) (Plastic insulation and sheathed wire)			Circuit Breaker Capacity (A)	Residual current device
		Phase line	Neutral line	Earth line		
TCAH100FC	380 V 3N - 50 Hz	6	6	6	40	30mA < 0.1s
TCAH50FC	380 V 3N - 50 Hz	2.5	2.5	2.5	32	30mA < 0.1s

Notes: 1.The residual current device provided for the outer part of TCAH50FC/TCAH100FC cannot be three-pole; instead, the four-pole switch with neutral line must be adopted.

2. When the distance from the external distribution circuit breaker to the air source heat pump water heater is too long, a larger wire diameter in the above table shall be adopted as per provisions of national standards.

3. The specifications of fuse provided for the unit control panel are as follows: 50T032H, rated current being 3.15A

CIRCULATING AIR SOURCE HEAT PUMP

and rated voltage being 250V, Φ5.2X20.

(2) Signal cable

There are many communication lines and signal cables between the master unit of hot water system and the slave unit of heat pump and also among the water tank, auxiliary heater and water pump. For the specific wiring specifications, quantity and requirements, refer to Table 5.7.

Table 5.7 Wiring requirements for signal cable of hot water system

Signal Cable	Minimum Size	Standard Length	Limit Length	Remarks
Communication line between master unit and wired controller	2*0.5 mm ²	30 m	50 m	Shielded cable, shielded twisted pair recommended
Communication line between slave units	2*1.0 mm ²	/	100m	Shielded cable, shielded twisted pair recommended
Water level switch signal cable	5*1.3 mm ²	20m	50m	
Signal cable of water tank temperature sensor	2*0.5 mm ²	10m	100m	
Signal cable of water flow switch	2*1.0 mm ²	/	100m	
Signal cable of water pressure switch	2*1.0 mm ²	/	100m	
External interlocking signal cable	2*1.0 mm ²	/	100m	
Signal cable of auxiliary heater control	2*1.5 mm ²	/	100m	The unit provides AC220V control signal.
Signal cable of circulating pump	2*1.5 mm ²	/	100m	The unit provides AC220V control signal.

Notes: The shielded cable of communication line must be connected to the earth wire, which can significantly improve the anti-interference ability of system.

(3) Requirements for power control cabinet

During the site installation of TICA air source heat pump water heater, a power control cabinet must be provided for the unit and all electric devices of the system. The power control cabinet needs to provide power supply for all heat pump units and circulating pumps in the system. See Table 5.8 for the power supply requirements for the above devices.

Table 5.8 Power supply requirements for devices in hot water system

Device in System	Power Supply Requirements	Remarks
Heat pump unit	380V 3N ~ 50Hz	
Circulating pump	220V ~ 50Hz or 380V 3N ~ 50Hz	Determine as per selected water pump specifications

The auxiliary heat source and domestic water feed pump are selected and configured by the user.

14. Sequence number setting of heat pump unit

When there are multiple units installed in parallel in the system, set the DIP switch for all heat pump units after installation and before commissioning. Open the electric box of heat pump unit and find two 8-bit DIP switches on the main board, S1 and S2 (see Figure 5.9). The detailed

CIRCULATING AIR SOURCE HEAT PUMP

setting method is described as follows. It is recommended to paste slave unit ID markings on the unit after setting.

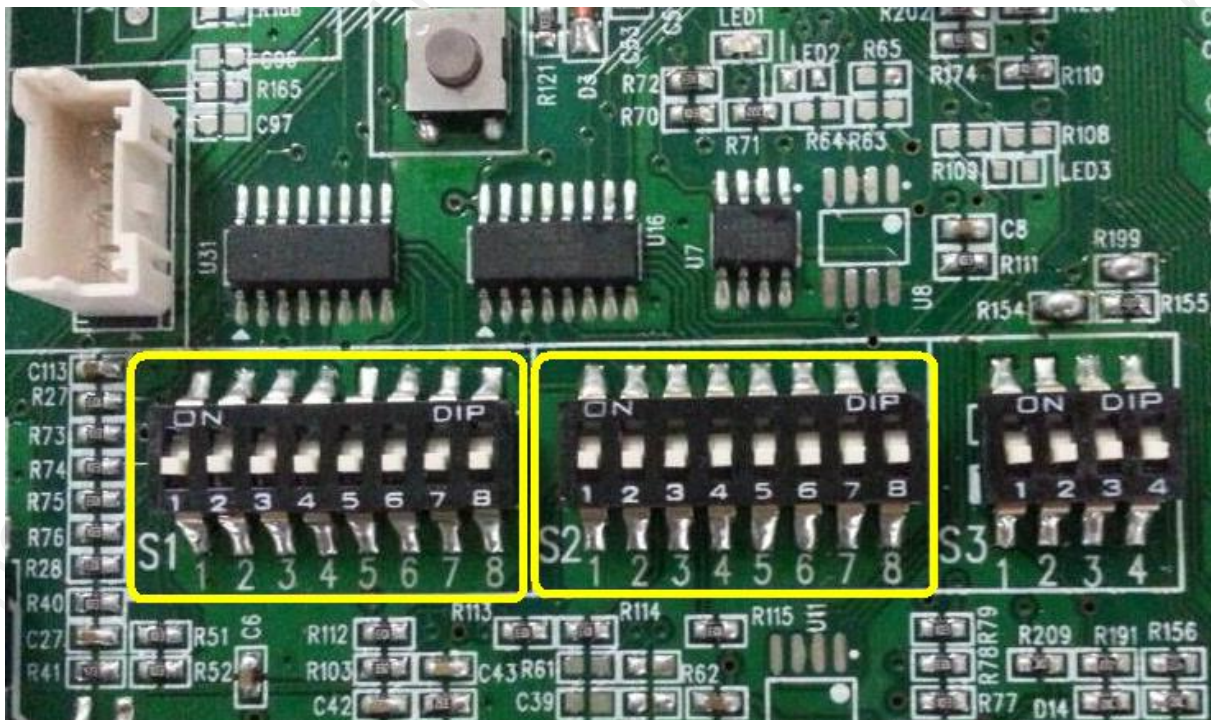

Figure 5.9 DIP switch

Model	S1								S2									
	1	2	3	4	5	6	7	8	1	2	3	4	5	6	7	8		
TCAH	Bit for master/slave unit selection		Unit type		Water level		Slave unit ID				Model capacity		Electric heater or not		Electric heater installation mode		The way of charging water	

Note: "ON" indicates open; "OFF" indicates close.

S1:

1, Bit 1 is for master/slave unit selection: "0" indicates slave unit; and "1" indicates master unit.

2, Bit 2-3 is for unit type, 00 indicates directly-heated type, 01 indicates circulating type.

3, Bit 4 is for water level, 0 indicates the unit with water level, 1 indicates without water level.

3, Bits 5 to 8 indicate the quantity of slave unit(s) or the slave unit ID:

- If the master unit is selected (that is, bit 1 of the DIP switch is set to "1"), bits 5 to 8 indicate the quantity of slave unit(s) (the binary digits 0000 to 1111 indicate 0 to 15 slave units respectively);
- If the slave unit is selected (that is, bit 1 of the DIP switch is set to "0"), bits 5 to 8 indicate the slave unit ID (the binary digits 0001 to 1111 indicate slave unit 1 to slave unit 15 respectively).

S2:

Bits 1 to 4 indicate the unit model: 0001 for 5HP; and 0010 for 10HP.

Bit 5 indicates whether the electric heater is available: "0" means unavailable; and "1" means

CIRCULATING AIR SOURCE HEAT PUMP

available.

Bit 6 indicates the installation mode of electric heater: "0" means that the electric heater is installed in the water tank; and "1" means that the electric heater is installed in the pipe.

Bit 7-8 is for the way of charging water selection, 00 indicates charging water depends on water level, 01 indicates charging water timing, 10 indicates charging water depends on setting temperature.

15. Trial operation

(1) Check before trial operation

- Unit check. Check whether the heat pump unit is properly installed; whether enough spaces are reserved for installation and maintenance; whether the pressure gauge is installed at the cold water inlet of unit; whether all the fastening screws and machine screws are tight; and whether the DIP switches of heat pump unit are set correctly.
- Piping system check. Check whether the pipelines of hot water system are all properly installed; whether the valves in the system pipelines are open; and whether all the pipelines are properly insulated.
- Power distribution system check. Check whether the power voltage of supply circuit is proper; whether all the screws of electrical parts are tightly fastened; whether the circuits distribute power as per the unit circuit diagram; whether the unit grounding is correct and reliable; and whether the ground fault circuit interrupter can act effectively.
- Before the trial operation of unit, clean the water system (note that the circulated cleaning of water system cannot be performed via the unit). After cleaning the water system, clean the cold water inlet and circulating water inlet filters.
- Power on. Power on the unit to check whether its wired controller displays faults. If yes, please troubleshoot them by referring to the error code; if no, make sure power has been applied to the unit at least 24 hours before testing and commissioning. After the unit is powered on, reset the system clock.
- Before the operation of circulating type unit, inspect the water flow. Press the "forced water pump" button of wired controller and drain out the water pump after operation. After water pump operates normally for some time, check whether the water flow meets requirements.

(2) Trial operation

- After the power-on time exceeds 24 hours, press the "ON/OFF" button on the wired controller to turn on the hot water system.
- After the compressor starts, judge whether the unit operates normally according to your hearing. In case of any abnormal sound, power off the unit immediately for a check; if no abnormal sound is heard, the unit can continue operating, and observe whether the water outlet temperature of unit is normal.
- Observe whether the fan operates normally without any abnormal noise.
- If the system operates normally, record its operating status, ambient temperature, water inlet and outlet temperatures of heat pump unit, water temperature and level of water tank current. Check whether the system operates normally according to the operating modes.
- The parameters of wired controller are preset by the manufacturer. Hence the users are not required to set them.
- When the unit is in commissioning, the operating parameters can be referred to Table 5.9.
-

CIRCULATING AIR SOURCE HEAT PUMP

Ambient tem.	Inlet water tem.	Discharge pressure (Mpa)	suction pressure (Mpa)	Discharge temp.	Suction temp.
-10~-5	5	1.1~1.5	0.2~0.4	30~50	-15~-7
-5~0	5	1.1~1.5	0.3~0.6	35~55	-10~-2
0~5	5	1.1~1.5	0.4~0.7	35~55	-7~2
5~10	10	1.2~1.8	0.5~0.8	35~55	-3~5
10~20	15	1.4~2.0	0.6~1.0	45~60	7~18
20~30	20	1.8~2.4	0.7~1.2	50~70	15~28
30	25	2.2~2.8	0.8~1.3	60~80	20

VI. Operation and Application of Wired Controller

1. Overview

This document is prepared to help users understand the operating procedures of the wired controller interface of TICA air source heat pump water heater. It includes the description of the changes in all user-defined settings, and some operating procedures of professional service personnel certified by TICA.

Warning:* The information and operating procedures described in the document shall be performed by the professional operators and service personnel certified by TICA.

* The operating manual is supplied with the unit. All the safety rules described in the document must be observed.

* For more unit information, contact TICA technical support service center.





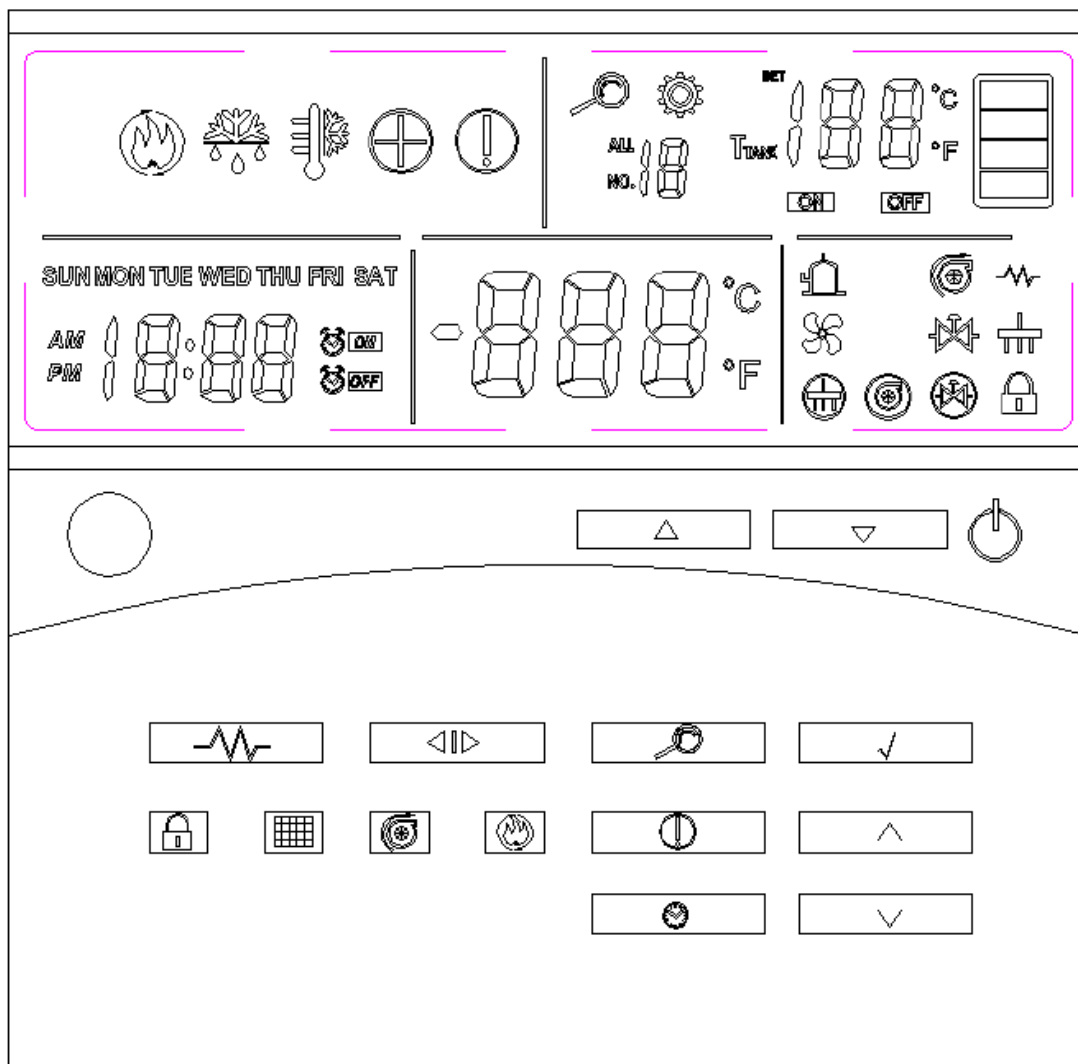



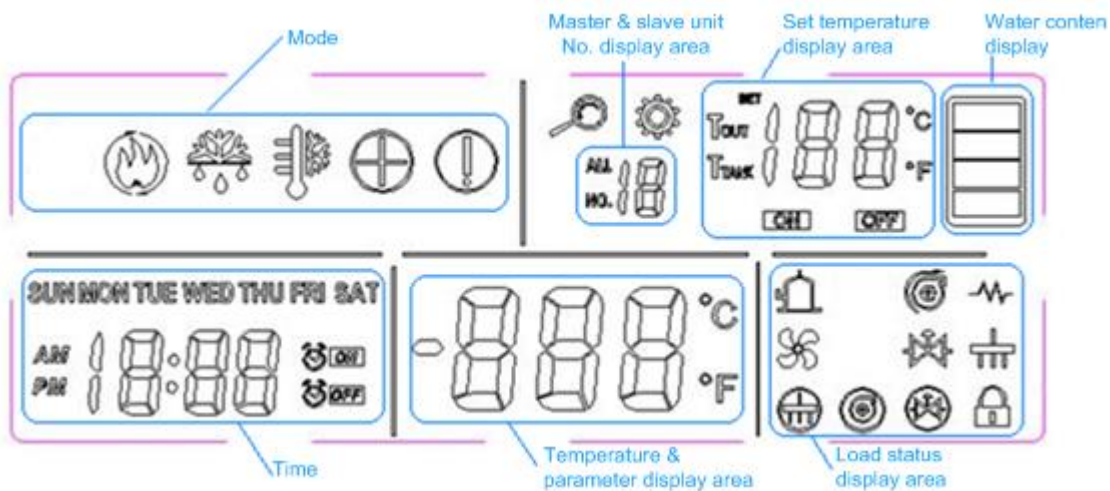









CIRCULATING AIR SOURCE HEAT PUMP

2. Overall outline drawing of wired controller



3. Pattern display description



Mode display area	 Circulating mode icon;  Defrosting mode icon;  Anti-freezing mode icon;  Auxiliary heater mode icon;  Fault prompt icon.
Master & slave unit No. display area	 Displays master and slave units 1 to 16;  Query icon ;  Parameter setting icon.
Set temperature display area	it can set the starting temperature of circulating mode T_{TANK} (range: 18~50°C, default value: 48°C);  indicates that the wired controller is turned up;  indicates that the wired controller is turned off.
Water level display area	Displays current water level of water tank intuitively.
Time display area	Displays current system time (including the week, am/pm, hour and minute); displays current setting time during timing setting;  indicates that "timed power-on" function is enabled;  indicates that the "timed power-off" function is disabled.
Temperatures and parameters display area	Displays the temperature, query and setting parameters.
Load status display area	 "Compressor on" icon;  "Circulating pump on" icon;  "Auxiliary e-heater on" icon;  "Fan on" icon;  "Water inlet solenoid valve on" icon;  "4-way valve on" icon;  Locking key status icon.

CIRCULATING AIR SOURCE HEAT PUMP

4. Button operation instructions

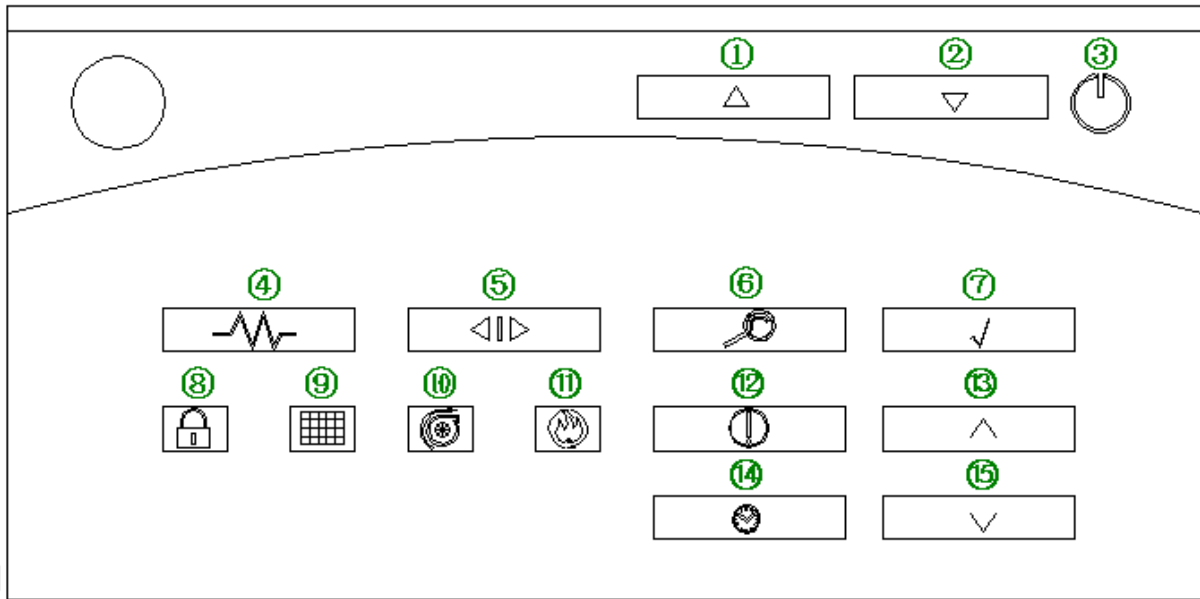

Buttons ① & ②	① Up button; ② Down button: adjusts values up or down.
Button ③	On/Off button: turns on/off the wired controller.
Button ④	Auxiliary Electric Heater Control button: turns on/off the auxiliary electric heater under power-on condition.
Button ⑤	Master & Slave Unit No. Switch button: switches the master and slave unit Nos..
Button ⑥	Query button: enters into the query mode via the button to inquire current operating temperature of unit.
Button ⑦	OK button: confirms the currently selected and set parameters.
Button ⑧	Child Lock button: locks (unlocks) the buttons.
Button ⑨	"charge water" button: it can charge water regularly.
Button ⑩	Forced Water Pump button: starts (stops) the circulating pump under power-off condition; can be used for engineering commissioning.
Button ⑪	Reserved
Button ⑫	Fault Query button: inquires current fault (or clears the fault).

Buttons ⑬ and ⑮	⑬ Page Up button; ⑮ Page Down button: they can be used for page turning.
Button ⑭	Timer button: sets timing and changes system time .

5. Wired controller operating instructions

(1) Temperature settings: they can only be valid under default state (i.e. non-query state and set state).

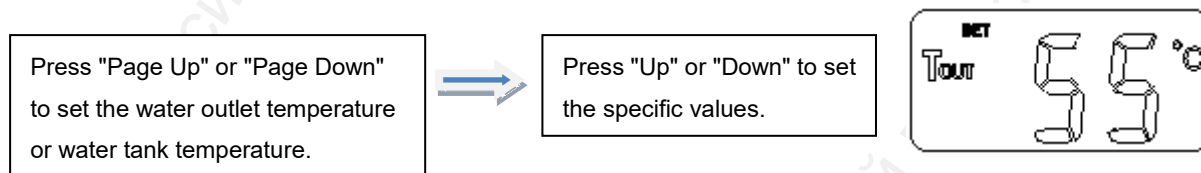

(2) Parameter query: under default state (i.e. non-query state and set state), press the "Query" button to inquire parameters.

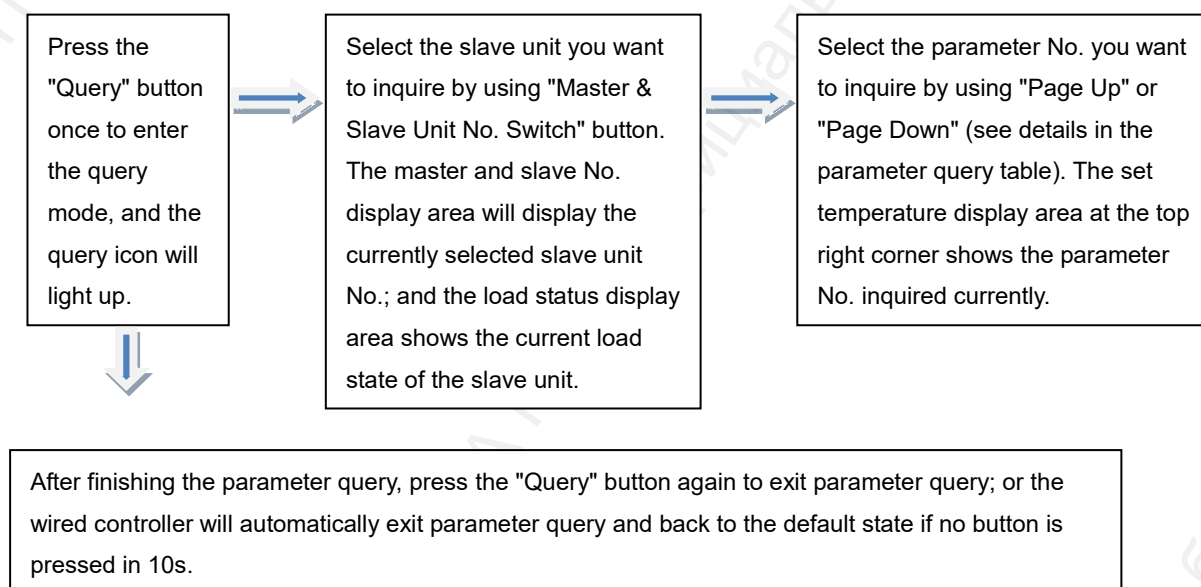

For example, if the user wants to inquire the ambient temperature of No.3 unit, he/she can operate as follows: press the "Query" button to inquire parameters and press the "Master & Slave Unit No. Switch" button to switch to No.3 slave unit and then press the "Page Up" or "Page Down" button to adjust the query number to 5. The temperature and parameter display area at the middle of LCD will display the current ambient temperature of No.3 unit (LCD displays as shown in Figure 6.1). After finishing the query, press the "Query" button again to exit parameter query; or the wired controller will automatically exit parameter query and back to the default state if no button is pressed in 10s.

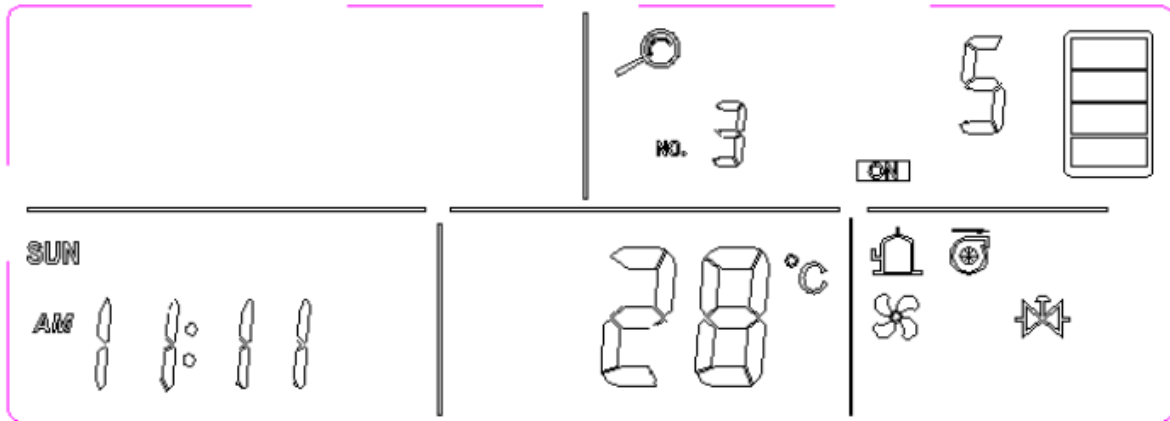

Figure 6.1 LCD display image during parameter query

Note: Comparison table of query parameters

No.	Display	Notes
1	Discharge temperature	Tp temperature value
2	Water tank temperature	Tt temperature value
3	Reserved	/
4	Water outlet temperature	To temperature value
5	Ambient temperature	Ta temperature value
6	Return air temperature	Th temperature value
7	Coil temperature	Tc temperature value
8	Circulating water inlet temperature	Tiz temperature value
9	Opening of electronic expansion valve	Actual opening of electronic expansion valve
10	Reserved	/
11	Fan wind baffle	F0: no air, F1: low air, F2: medium air. F3: strong air
12	Operating current of compressor	Unit: A, only integer displayed
13	Model code	Direct-heating type unit: A03 (3HP), A05 (5HP), A10 (10HP)
14	Main board software version	V1.0
15	Wired controller software version	V1.0
16	Last error code	
17	Second last error code	
18	Third last error code	
19	Fourth last error code	
20	Fifth last error code	
21	OE	End
22	Reserved	/

(3) Fault query: In case the system generates a fault alarm and the wired controller is in default

CIRCULATING AIR SOURCE HEAT PUMP

state (i.e. non-query state and set state), press the "fault query" button to inquire faults (see detailed error codes in the error code list).

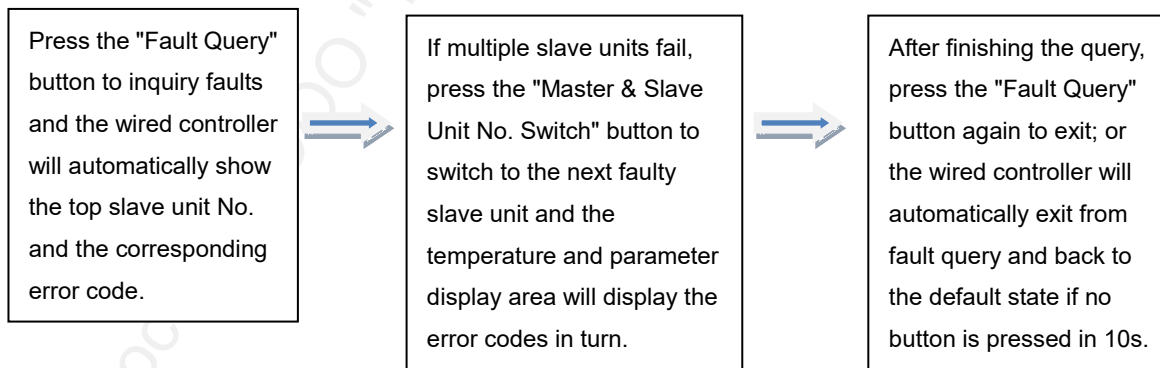

(4) Fault clearing: In case the system generates a fault alarm and the wired controller is in default state (i.e. non-query state and set state), press and hold the "Fault Query" button for 3s to clear the current system fault (if the same fault occurs several times in a short period, contact the after-sales service).

(5) Timing setting: Under default state (i.e. non-query state and set state), press the "Timer" button to enter the timing setting.

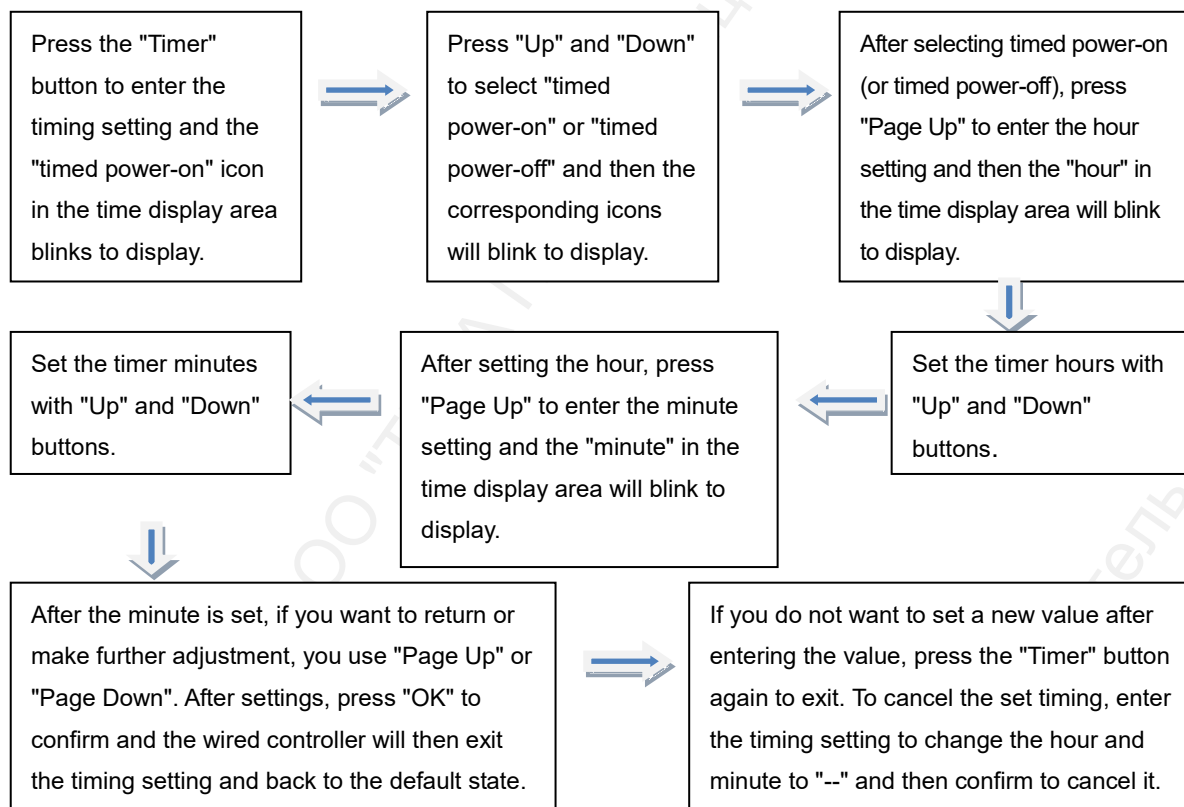

Notes: 1. The timing function allows the users to preset the power-on (or power-off) time for the wired controller at random.

2. Once the timing function is enabled, the corresponding timed power-on (or timed power-off) icon will then light up. A light-up icon indicates that the corresponding function is enabled. Notes: In general, the hour and minute in front of the timed power-on (off) icon display the current time. However, during the timing setting or time calibration, the hour and minute refer to the current setting value.

CIRCULATING AIR SOURCE HEAT PUMP

3. The timing function supports timed power-on (or timed power-off) separately. When you only want to set the timed power-on, set the hour and minute of the timed power-off to "--" and then confirm; when you only want to set the timed power-off, set the hour and minute of the timed power-on to "--" and then confirm. Observe the illumination condition of timed power-on or power-off icon to determine whether the timing function is enabled.

For example, if you want to set the power-on time to 6:30 and power-off time to 11:30, you can operate as follows: when the wired controller is in default state (i.e. non-query state and set state), press the "Timer" button and the timed power-on icon in the LCD time display area blinks to display; press "Page Up", the hour value blinks to display; and regulate the hour as AM 6:00 with "Up" or "Down" button; and continue to press "Page Up", the minute value blinks to display and regulate the minute as AM 6:30, then the power-on time is set as 6:30 (LCD display is as shown in Figure 6.2). Next, press "Page Up" and enter the timed power-off time setting when the corresponding icon blinks to display; and set the timed power-off hour and minute as PM 11:30 with the same method; then the time is set (LCD display is as shown in Figure 6.3). Press "OK" to confirm and then the wired controller will automatically exit from timing setting and back to the default state; and at the same time, the timed power-on and power-off icons are illumed (LCD display is as shown in Figure 6.4).

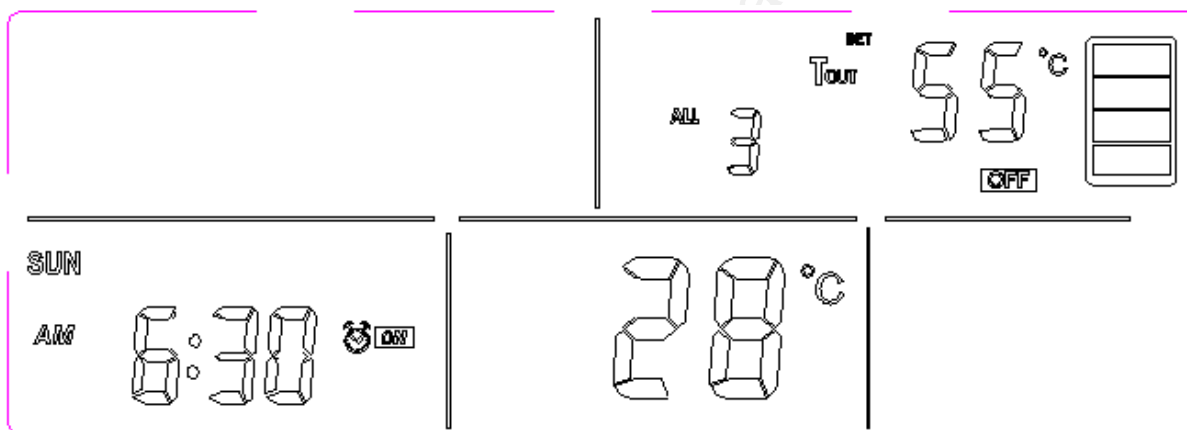

Figure 6.2 LCD drawing of timed power-on setting

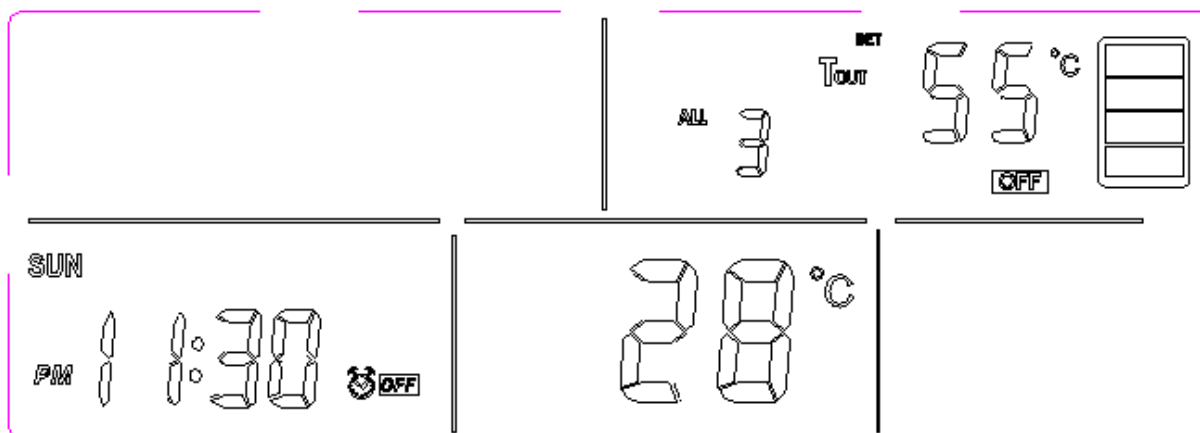

Figure 6.3 LCD drawing of timed power-off setting

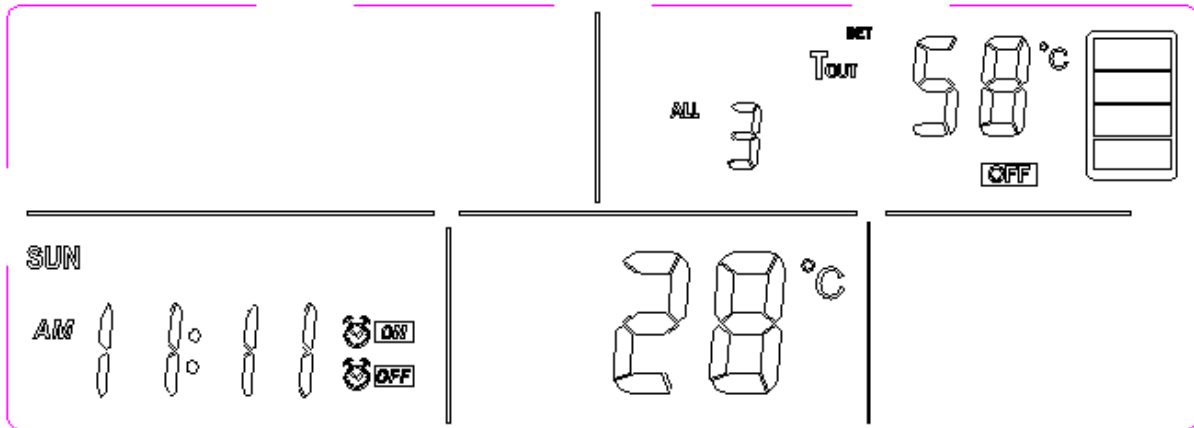
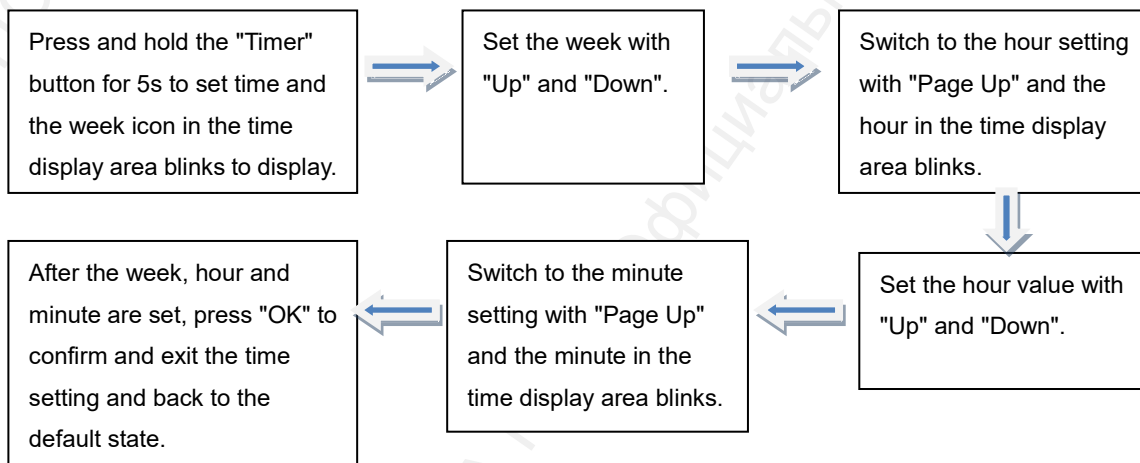

Figure 6.4 LCD drawing of timing function enabling

(6) Time setting: when the display time of wired controller deviates from the standard time, it can be reset when the wired controller is in the default state.



Note: During the time setting, press the "Timer" button to exit the time setting; or the wired controller will automatically exit from time setting and back to the default state if no button is pressed in 10s.

For example, if the user wants to adjust the time display of wired controller as AM 10:30 on Monday, he can operate as follows: when the wired controller is in default state, press and hold the "Timer" button for 5s to enter the time setting and the week blinks; adjust the week to MON with the "Up" or "Down" button; press "Page Up" to switch to hour setting, and adjust the hour to 10:00 with the "Up" or "Down" button; and then press "Page Up" to switch to minute setting and adjust it to 10:30 with the "Up" or "Down" button; at this moment, the week, hour and minute are set well; press "OK" to confirm and then the wired controller returns to default state and the time displays as the time settings just set (LCD display as shown in Figure 6.5 below).

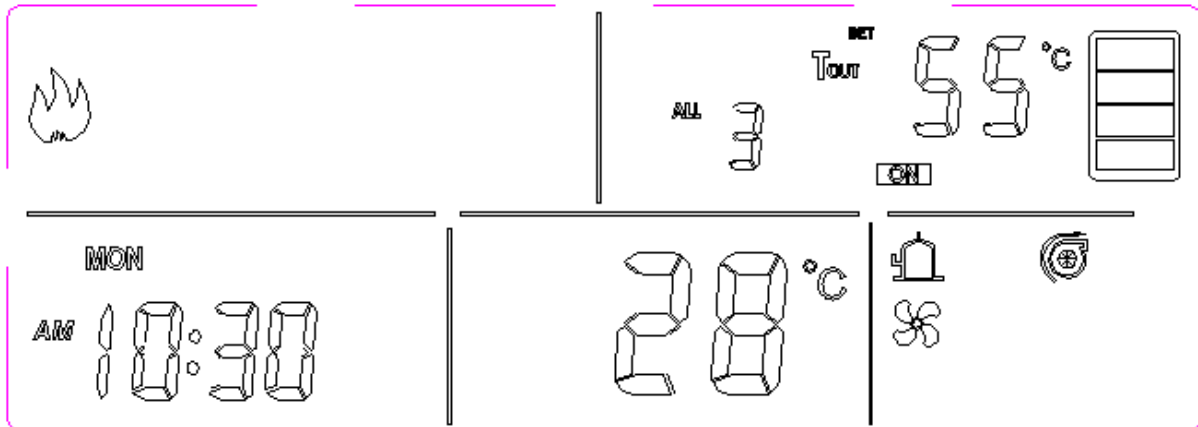
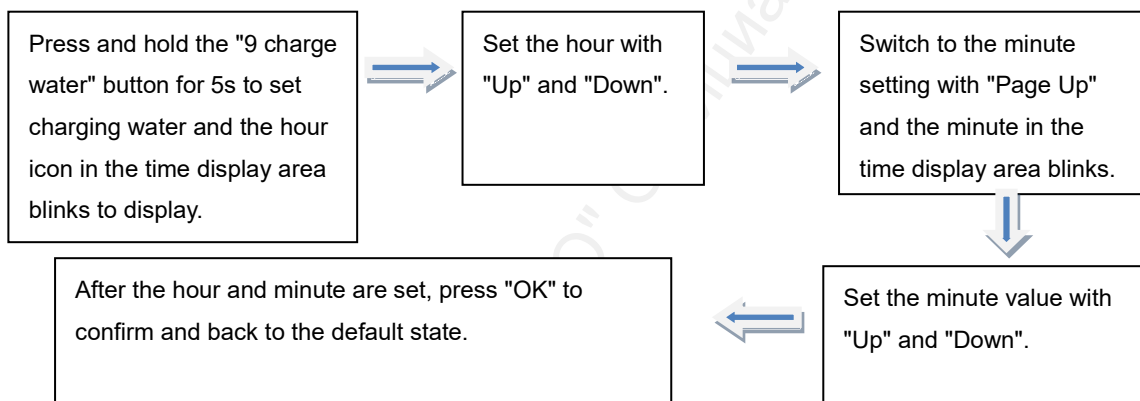

Figure 6.5 LCD drawing of time setting

(7) Timing charging waterfunction: When the unit is equipped with water level switch and the water replenishment dialing mode is timing water replenishment, this function is effective. In default state (i.e. non-inquiry and setup state), the wire controller can set timing water replenishment.



(8) Key lock function: when the wired controller is in default state (i.e. non-query state and set state), key lock can be achieved via "Child Lock" button. During key lock, except for the "Child Lock" button, other buttons do not response. Under key lock state, press the "Child Lock" button again to unlock.

(9) Forced Auxiliary Electric Heating Opening Function: Wire Controller is on-unit and the default. Auxiliary Electric Heating is controlled by keys to turn on or off Auxiliary Electric Heating.

(10) Forced water pump function: when the wired controller is off or in its default state (i.e. non-query state and set state), turn on or turn off the circulating pump via the "Water Pump Control" button.

Note: All above functions can be quitted via the "On/Off" button.

VII. Servicing and Maintenance

Warning: • This air source heat pump water heater shall be serviced and maintained by qualified professional operators and service personnel as incorrect operations may lead to serious injuries or property losses.

- For any abnormalities or alarms occurring during operation, note to call TICA's hotline or report them to your local service agency. And never attempt to repair them on your own.
- Before servicing and maintaining the water heater unit, do disconnect the circuit breaker.

CIRCULATING AIR SOURCE HEAT PUMP

- Install the inlet and outlet pipes in the correct direction.
- On the water inlet pipes, water filters should be installed. In addition, these filters need to be cleaned periodically, lest water-side heat exchanger may be clogged, hence causing damages to the unit. In order to prevent the parts at the hot water side from damage, the maximum water inlet pressure cannot exceed 1 Mpa.
- The unit must be equipped with water flow switch to provide effective protection in case of low water flow; otherwise, the unit may be damaged.
- The water pump model selection must satisfy the flow requirement of the unit. Too large or too small water flow will influence the normal operation and service time of the unit to different extents. The switch signal of the water pump must be controlled via the unit.
- The unit shall be equipped with water tank with suitable capacity as too large or too small capacity will influence the unit operation.
- Check periodically to make sure that water supply devices and air discharge devices function well, lest water supply cuts occur or air enters into the system, hence affecting the unit's performance and reliability.
- Note to clean the water filters of water system regularly (once every two to three months recommended) to make sure water flows smoothly and abundantly, lest the dirt may clog the filter and alarm to shutdown, and hence affect the operation reliability of the system.
- Check the working conditions of each component of the unit regularly and check whether the work pressure of the cooling system of the unit is within the normal range. Check whether there are oil dirt on the pipeline connectors and valves of the unit to ensure that no refrigerant leaks out.
- Check whether wiring of the unit power supply and electrical system is secure, and whether electrical components work well and have no smell. For any abnormalities, repair or replace the faulty parts in a timely manner.
- Do not open or close the water system valves at will during unit operation. Otherwise, the normal operation of the unit may be affected, and the unit may be damaged.
- Never short circuit the protective device of unit, as it may damage the unit.
- It is forbidden to run the compressor of the unit in a reverse direction. Note to make sure that the power supply and electrical components of the unit work properly.
- Do not use sharp objects when operating the controller. Do not impose excessive force, lest the controller panel may be damaged.
- The minimum starting voltage of the unit must be kept above 90% of the rated voltage, the voltage must be within $\pm 10\%$ of the rated voltage range during operation, and the voltage difference between the phases should be within the range of $\pm 2\%$. An adverse impact will be caused to the unit when the voltage is too high or too low. Make sure the power supply is stable. Otherwise, when the unit starts, it may generate excessive current, thus making it impossible to start.
- Install the unit in a dry, clean and well ventilated place. To guarantee the heat transfer effect of the heat exchanger at the air side of unit, use the dedicated detergent for finned heat exchanger to clean it. The recommended cleaning period is 12-24 months, which mainly depends on the environmental conditions around the unit installation site. The specific cleaning method is as follows: dilute the detergent solution specific to the finned heat exchanger with water in certain proportion and spray the diluent onto the fin surface with watering can; and after reacting for 3-5 minutes, flush with water with some pressure. And

CIRCULATING AIR SOURCE HEAT PUMP

during flushing, the water pressure cannot be too large to damage fins and also pay attention to avoid spraying water onto other live parts.

- For efficiency and safety considerations, take care to clean water-side heat exchanger with detergent. Recommend once every 2 to 6 months, depending on the local water quality and usage time.
- Never run the unit where acid, alkali, salt spray and other corrosive gases are present, as it will damage the unit casing, pipeline or electrical components.
- Do not relocate the temperature probe. Otherwise, the unit's automatic control program will be affected, which may cause operation of the unit unlikely or unit damages.
- Do not use unqualified refrigerant, refrigerant substitute or refrigerant additive. Incorrect using method or using unqualified refrigerant, refrigerant substitute or refrigerant additive will lead to unit damage and various safety hazards. Please select qualified refrigerant or call TICA hotline to purchase qualified refrigerant. All the technicians operating refrigerant must have acquired qualification certificates, and know very well and strictly observe the technical requirements, laws and regulations related to refrigerant use, handling, recovery, and recycling. When charging or adding refrigerant to the unit, make sure that the charging amount and refrigerant type are consistent with the information on the unit nameplate. A refrigerant charging mistake may lead to a unit fault or other potential safety hazards.
- The automatic anti-freezing function of the unit can only ensure that the internal pipeline of air source heat pump water heater is free from freezing. Therefore, in order to ensure the whole water system pipelines are free of freezing, the anti-freezing heat belt must be winded on the whole water system pipelines during engineering installation. The company assumes no liability for the frost damage problems caused by the lack of installation of anti-freezing heat belt.
- When the ambient temperature is below 0°C, do not turn off the power in case the unit is idle. Otherwise, some parts may suffer from frost crack, and the company does not assume any liability for losses arising from such problems.
- Only the direct-heating or circulating heating type unit can be used to provide domestic water and cannot be used to heat, provide heat sources or heat swimming pool.

VIII. Handling of Common Faults

1. In case of faults, judge and clear faults according to the error codes of wired controller before applying for servicing.

Code	Fault description	Cause	Handling Method
E00	Communication faults	1. The slave unit is not powered on 2. Communication cable gets loose or wrongly connected 3. Control panel is damaged	1. Check whether the power switch of power control cabinet and that of each slave unit are closed 2. Check the communication line sequence between the wired controller and master unit or between the master unit and slave unit and then tighten it 3. Replace the control panel
E01	Power phase sequence	Power phase dislocation or loss	Check the power supply of unit

CIRCULATING AIR SOURCE HEAT PUMP

	fault		
E02	Water temperature sensor fault in the water tank (only the master unit displays)	<ol style="list-style-type: none"> 1. Temperature sensor gets loose wires 2. Temperature sensor is damaged 	<ol style="list-style-type: none"> 1. Check its wiring and tighten them 2. Replace temperature sensor
E03	Water outlet temperature sensor failure		
E04	Direct-heating water inlet temperature sensor fault		
E05	Circulating water inlet temperature sensor fault		
E06	Discharge temperature sensor failure		
E07	Fin-tube heat exchanger tube temperature sensor fault		
E08	Return air temperature sensor fault		
E09	Outdoor ambient temperature sensor fault		
E12	Circulating water flow fault	<ol style="list-style-type: none"> 1. The water flow sensor wiring is loose 2. Lack of water or valve not wide open 3. The water flow is small and the water filter is blocked by dirt 	<ol style="list-style-type: none"> 1. Check its wiring and tighten them 2. Check the circulating pipeline and open it fully 3. Clean water filter
E13	Abnormal water level switch	<ol style="list-style-type: none"> 1. The water level switch wiring gets loose 2. The water level switch is wired wrongly 3. The low water level floater is damaged 	<ol style="list-style-type: none"> 1. Check the water level switch wiring and tighten it 2. Check whether the water switch is wired as the wiring drawing 3. Replace the low water level floater or water level switch
E14	Abnormal water level switch	<ol style="list-style-type: none"> 1. The water level switch wiring gets loose 2. The water level switch is wired wrongly 3. The medium water level floater is damaged 	<ol style="list-style-type: none"> 1. Check the water level switch wiring and tighten it 2. Check whether the water switch is wired as the wiring drawing 3. Replace the medium water level floater or water level switch
E15	Abnormal water level switch	<ol style="list-style-type: none"> 1. The water level switch wiring gets loose 2. The water level switch is wired wrongly 3. The high water level floater is damaged 	<ol style="list-style-type: none"> 1. Check the water level switch wiring and tighten it 2. Check whether the water switch is wired as the wiring drawing 3. Replace the high water level floater or water level switch
E16	Water tank overflow	<ol style="list-style-type: none"> 1. Water tank overflow prompt 	<ol style="list-style-type: none"> 1. Check the water level of water tank

CIRCULATING AIR SOURCE HEAT PUMP

	prompt	<ol style="list-style-type: none"> 2. The water level switch wiring gets loose 3. The water level switch is wired wrongly 4. The overflow water level floater is damaged 	<ol style="list-style-type: none"> 2. Check the water level switch wiring and tighten it 3. Check whether the water switch is wired as the wiring drawing 4. Replace the overflow water level floater or water level switch
E17	Protection of too high outlet water temperature	<ol style="list-style-type: none"> 1. The project water supply pressure is too small 2. The stepping water valve is closed insufficiently 3. The water flow is very small as the water system is blocked by dirt 	<ol style="list-style-type: none"> 1. Check the project water inlet pressure and keep it within suitable range 2. Check whether the stepping water valve wiring and water valve are damaged 3. Clean water filter
E18	Remote interlocking protection	Remote control node is disconnected	Check the remote control node wiring
E19	Excessive temperature difference between circulating water inlet and outlet	<ol style="list-style-type: none"> 1. Low water flow 2. Water filter blocked by dirt 	<ol style="list-style-type: none"> 1. Check whether the valves are wide open, whether the water pump lift and flow meet requirements 2. Clean water filter
E20	Protection of too high discharge temperature	<ol style="list-style-type: none"> 1. Fluorine leaks 2. Non-condensable gas exists in the system 3. The coil temperature sensor comes off 	<ol style="list-style-type: none"> 1. Detect leaks and add refrigerant again 2. Refill the refrigerant 3. Check and fix the coil temperature sensor
E21	Low pressure protection of system	<ol style="list-style-type: none"> 1. Low pressure switch gets loose wires 2. Refrigerant leaks 3. Throttle device is blocked 4. Evaporator fails to exchange heat well 5. Low pressure switch is damaged 	<ol style="list-style-type: none"> 1. Check its wiring and tighten them 2. Detect leaks and add refrigerant again 3. Replace throttle device 4. Check and clean evaporator 5. Replace low pressure switch
E22	High pressure protection of system	<ol style="list-style-type: none"> 1. High pressure switch gets loose wires 2. Low water flow 3. Water filter blocked by dirt 4. Dirt deposits on the condenser 5. Refrigerant filter or throttle device is blocked 6. High pressure switch is damaged 7. The tap water supply is interrupted 	<ol style="list-style-type: none"> 1. Check its wiring and tighten them 2. Check whether the valves are wide open, whether the cold water inlet pressure is too small and whether pump lift and flow meet requirements 3. Clean water filter 4. Clean condenser 5. Replace filter or throttle device 6. Replace high pressure switch 7. Check the tap water supply system
E23	Over-current protection of compressor	<ol style="list-style-type: none"> 1. Excessive compressor current 2. Current mutual inductor is 	<ol style="list-style-type: none"> 1. Check the compressor wiring 2. Replace current mutual inductor

CIRCULATING AIR SOURCE HEAT PUMP

		damaged	
CF	The ambient temperature is too low and the heat pump is limited to start up	<ol style="list-style-type: none"> The ambient temperature is lower than -10°C The ambient temperature sensor of unit is damaged 	<ol style="list-style-type: none"> Confirm whether the ambient temperature is lower than -10°C Replace the damaged ambient temperature sensor

2. It is normal in case that following circumstances occur to the unit.

	Phenomena	Cause	Solution
	The final circulating water temperature is lower than the set temperature.	In order to protect the unit, after the heat pump circulation is terminated, the water temperature may not reach the set temperature, which is a normal phenomenon and does not affect the unit operation.	Under low ambient temperatures, the auxiliary heat sources shall be provided to heat the water temperature of water tank up to the set value.
	Minimum shutdown protection of compressor	When the unit is restarted for operation after stopping running, the unit will not start up within 3 minutes, which is a protective measure to the compressor operation carried out by the control system, therefore, it is a normal state.	—

3. In case the following circumstances occur to the unit, check again.

It is a fault, check again.	The unit does not run.	<ol style="list-style-type: none"> Power supply fault The unit power supply wiring gets loose. The fuse of the unit control power supply is broken. The set time of timer is up. 	<ol style="list-style-type: none"> Disconnect the power switch and check the power supply. Tighten the loose power supply wiring. Replace the fuse. Cancel the timing or reset.
	The water pump runs while the water does not circulate or the water pump noise is big.	<ol style="list-style-type: none"> The water system lacks of water. There is air in the water system. The water system valves are not completely opened. The water filter is blocked by dirt. 	<ol style="list-style-type: none"> Check the water refill device of the system and feed water to the system. Drain out the air in the water system. Open the valves not opened in the water system. Clean the water filter.

CIRCULATING AIR SOURCE HEAT PUMP

	The unit heating capacity is low and the compressor does not shut down.	<ol style="list-style-type: none"> 1. The water system is poorly insulated and the heat release is large. 2. The heat release of the heat exchanger at the air side is poor. 3. Low water flow 4. The water tank capacity is a little small and the heat pump units equipped cannot meet the actual water consuming requirements. 	<ol style="list-style-type: none"> 1. Strengthen the system pipeline insulation. 2. Check whether the air inlet or outlet of the unit is blocked. 3. Clean the water filter or discharge the air from the water system. 4. It is recommended to make corresponding modifications according to the actual water consumption.
	The compression does not run.	<ol style="list-style-type: none"> 1. The compressor contactor is damaged. 2. The wiring gets loose. 3. Compressor overload protection 4. The water temperature is set wrongly. 5. Low water flow 	<ol style="list-style-type: none"> 1. Replace the contactor. 2. Check the wiring and tighten them (if required). 3. View the wired controller display panel to see whether there is a fault alarm. 4. Reset the water temperature. 5. Clean the water filter or discharge the air from the water system.
	The fan is faulty.	<ol style="list-style-type: none"> 1. The fan relay is damaged. 2. The motor is burned. 	<ol style="list-style-type: none"> 1. Replace the fan relay. 2. Replace the fan motor

IX. Appendix

1. Unit circuit diagram

Electrical principle diagram of TCAH100FC

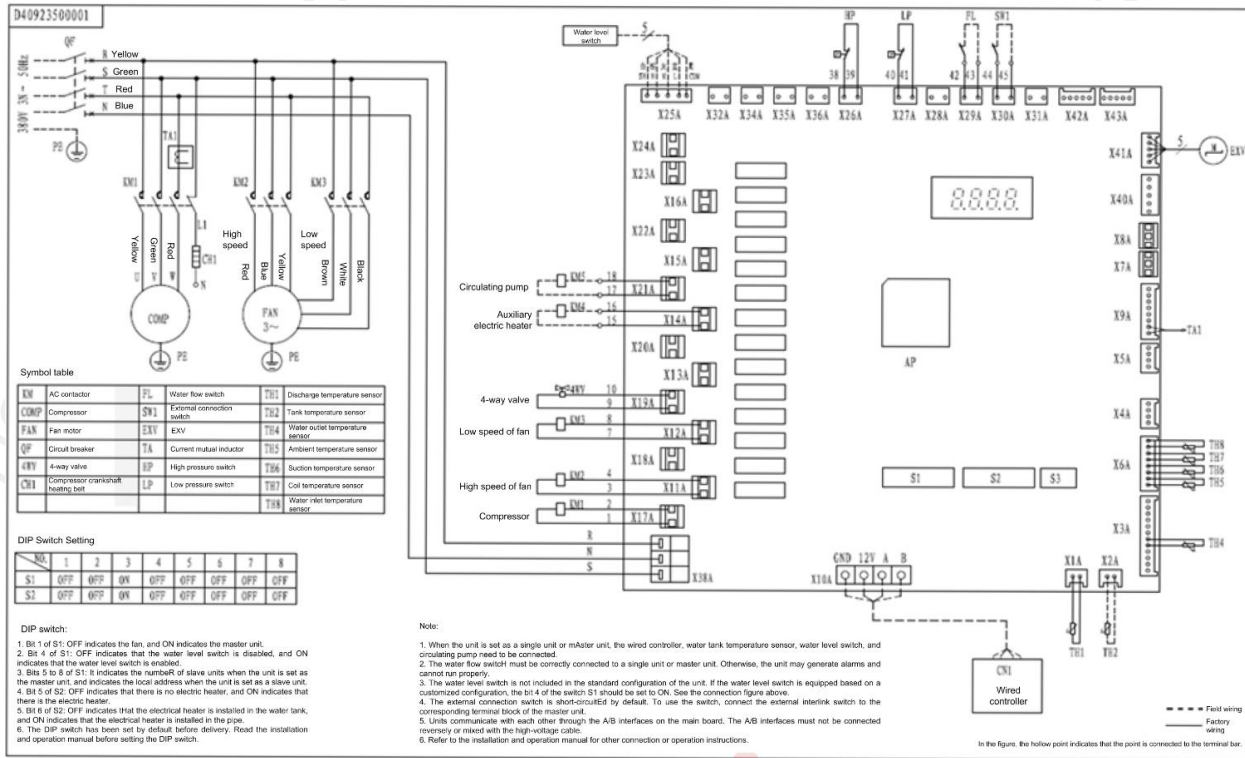

Electrical principle diagram of TCAH50FC

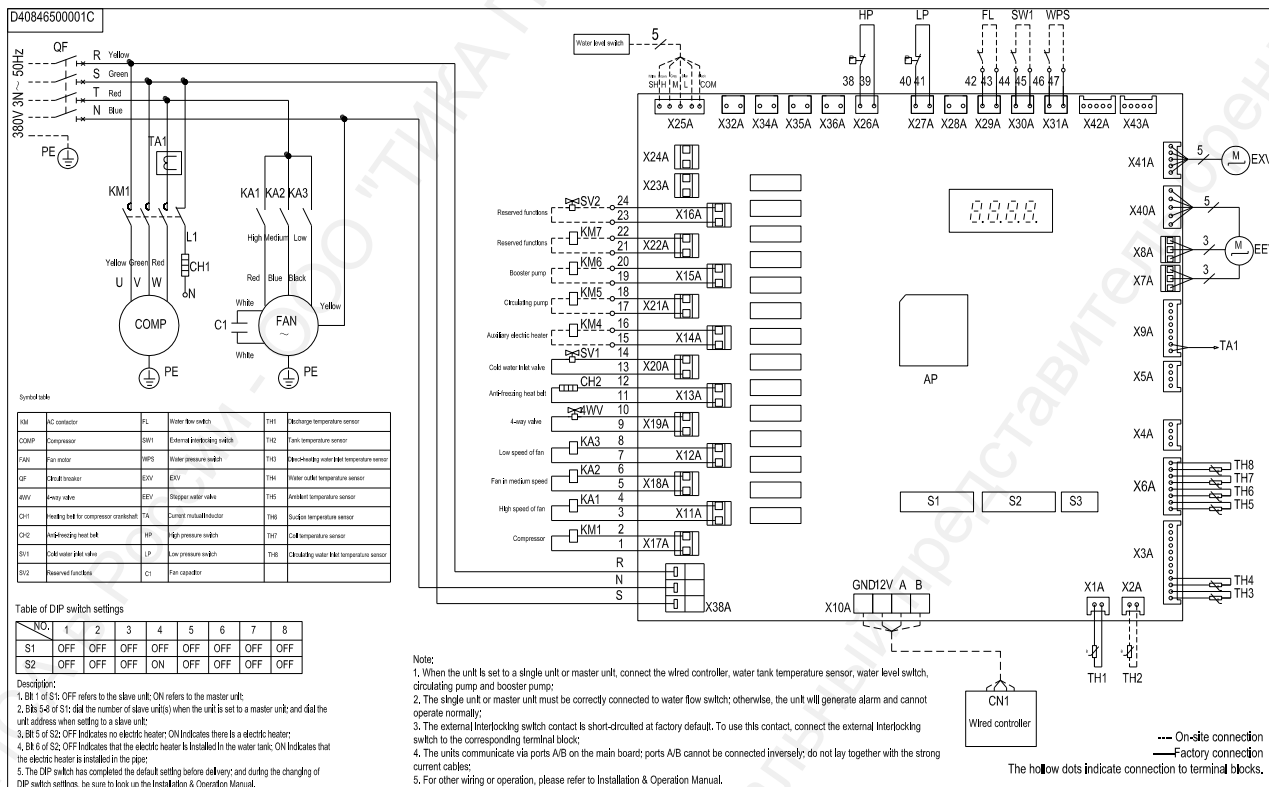

2. Wiring diagram of single unit

Wiring diagram of single TCAH50FC/TCAH100FC unit

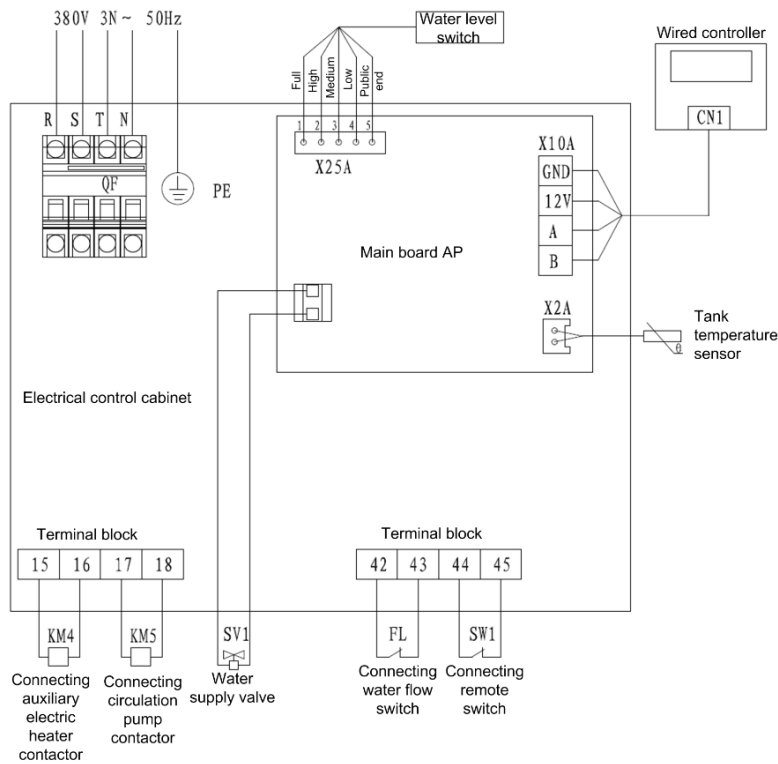

3. Wiring diagram of multiple parallel units

Wiring diagram of multiple parallel units of TCAH50C/100FC

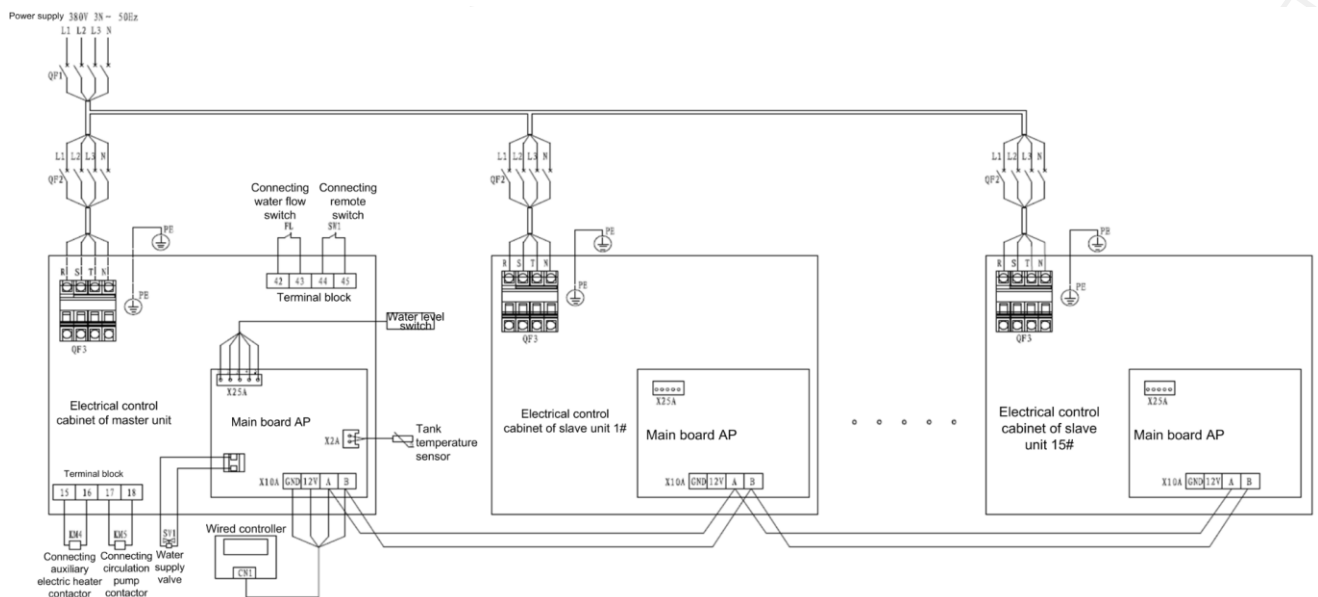

Remarks:

(1) The control output points for the auxiliary electric heater, circulating pump and booster pump in the figure can only be used as control signal ports; and the output power supply of ports is

CIRCULATING AIR SOURCE HEAT PUMP

AC220V - 50Hz;

(2) Users can only connect the passive switches to the control input points for the water level switch, remote switch and water pressure switch in the figure.

(3) The unit comes with the communication line between the master unit and wired controller; the communication lines between the master unit and slave unit or between the master unit and slave unit need to be prepared by the users. Do not lay the communication lines together with the strong current cables. Shielded twisted pair is recommended.

(4) Up to 16 units of the same model can be connected in parallel.

(5) The following connection modes of communication line are prohibited.

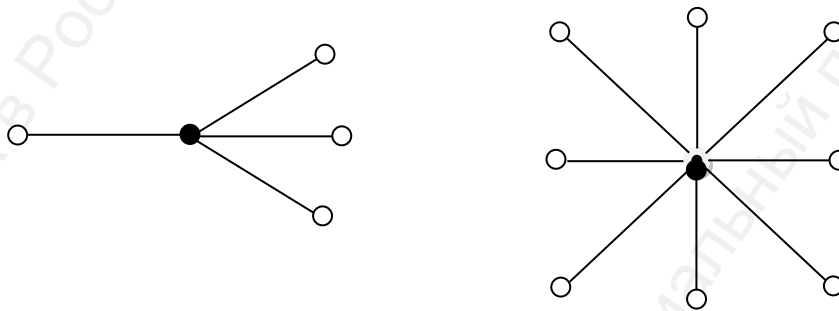



TICA PRO LLC

141014, Russia, Moscow oblast, Mytishchi,
Very Voloshinoy Ulitsa, office 705 and 805

Tel.: +7(495)822-29-00

E-mail: info@tica.ru

www.tica.ru