

Fan Coil Unit

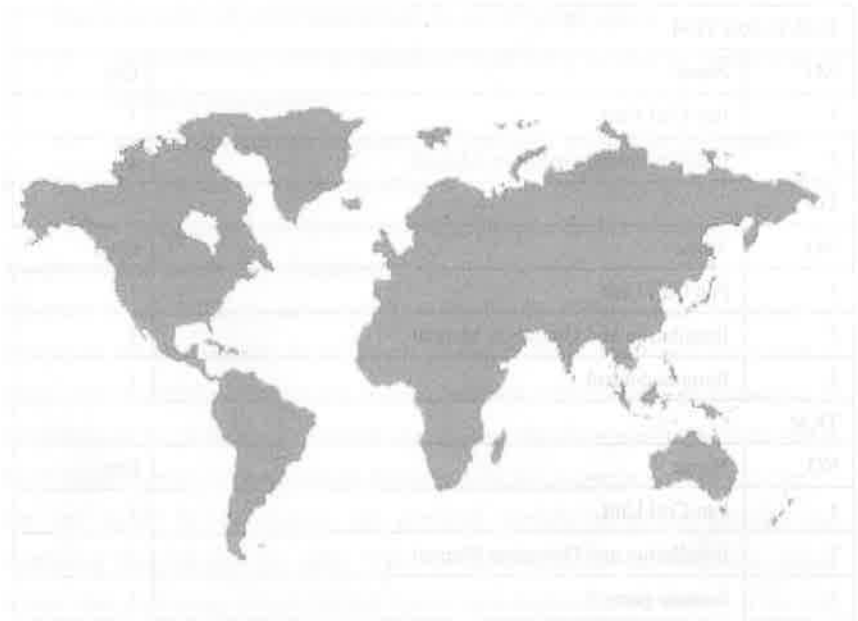

Installation and Operation Manual

FORM NO.B21101KT2

Packing List

TCR/TCRQ/TFM		
NO.	Name	Qty.
1	Fan Coil Unit	1
2	Installation and Operation Manual	1
TC		
NO.	Name	Qty.
1	Fan Coil Unit	1
2	Installation and Operation Manual	1
3	Remote control	1
TKM		
NO.	Name	Qty.
1	Fan Coil Unit	1
2	Installation and Operation Manual	1
3	Remote control	1

- Note: Installation and maintenance require qualified personnel who are familiar with local standards and rules of installation and maintenance and are experienced with these types of machines.
- Caution: Mind the sharp edges and surfaces to avoid scratch.
- Warning: Machines in operation and power source are dangerous, which may cause injures or death. All power sources must be cut off before repairs.
 - ◇ Air-conditioning units are prohibited from being installed in combustible or explosive environments.
 - ◇ Air-conditioning units are prohibited from being installed in laundry mats.
- Remarks: Due to our continuous effort to innovate and improve its products, we reserve the right not to notify you if unit specifications or data is modified.

Acceptance and installation of equipment

All series of our FCUs are tested and inspected before delivery to the customers. In delivery to the building site, all FCUs are packed in carton boxes and transported in proper form in order to keep the unit in good condition until it reaches its destination. If the cartons are found damaged obviously, please check the unit immediately. If the unit is found damaged, please inform both the forwarders and the recipients to check together.

The unit should be kept indoors and protected carefully to prevent moisture and weathering from harming the units. When the units are taken out of cartons, please prevent dust, packaging, and any foreign objects from dropping on the surface of the unit, in the fan casing and heat exchangers, which can cause damage to the unit.

Preparative work

Before installing the unit, please check task hereinafter without fail:

- (1) If the position of the electrical interface connection, chilled water and condensing pipes are correct. If the size of air-return pipe or air-out pipes are correct.
- (2) If enough space is left for installation of the unit and regular maintenance.
- (3) If enough tension is left for suspender structure to support weight of unit and if the position of suspender bolts are right.
- (4) If the size of air-return pipe or air-out pipe are installed for high static pressure units, and if resistance is in accordance with the scope of operating pressures.

Unit Installation

(1) Installation of water pipes

All the pipes including water inlet pipes and water outlet pipes must be installed according to engineering drawings and products drawings in the process of installation. The water pipes must be fixed with a hook in the wall and ceiling accurately, and then be connected with the unit. Enough clearance must be left for installation of the pipe in order to allow electric supply, passing of control line and insulation material, which is in the necessary thickness. All main water pipes must have enough bracing to support the weight of water and the pipe itself. When pipes are fixed, enough clearance must be left to contain expansion when hot water passes and contract when cold water passes.

(2) Direction of pipe connection

The FCU series when facing the air-out supply duct, the drain is on the left is left-type, vice-versa is right-type.

(3) Connection of pipeline

The inlet pipes for chilled water of the FCUs are below, while outlet pipes are above. When installing, you must insure that connecting of screw thread is absolutely tight. After pressure testing, the pipeline should be sealed with insulation. The valve body of the pipeline should be in scope of unit drain pan, otherwise, insulation of drain pan should be added in order to prevent condensing water from destroying unit and area around it. Condensing water pipes should be insulated, and the gradient is advised to not less than 1:75 in order for favorable drainage.

Caution: Do not exert excessive pressure when tightening the pipe to prevent permanent damage to the FCU

(4) Electrical Installation

Please insure the connection of electric systems is by professional personnel with electrical experience.

All wiring of electricity must be in accord with regulation of national standards and local standards.

Before connection, please read wiring diagram of electricity offered with unit.

Ceiling Concealed FCUs: TCR/TCRQ

On top of the TCR/TCRQ there are waist-shape apertures for suspender. Customers are advised to use full threaded screws flat washer, lock washer and nut to make the unit

sturdy when in operation.

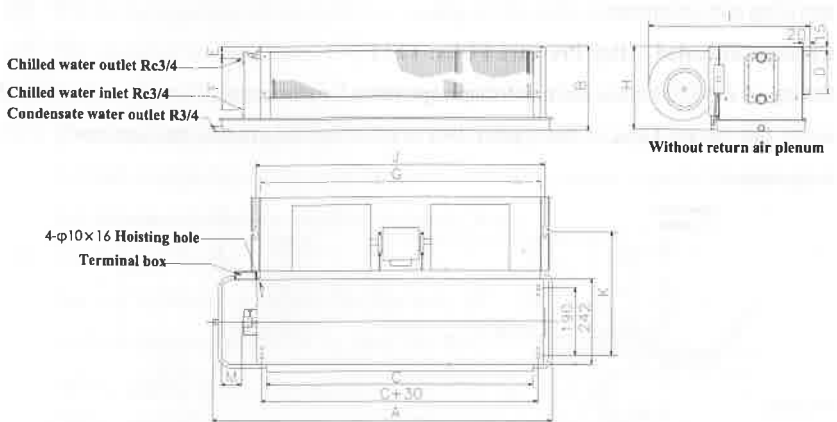

TCR	A	B	C	D	E	F	G	H	I	J	K	M	Motor Num.	Fan Num.
200	695	230	435	135	54	118	477	225	470	504	346	50	1	1
300	845	230	570	135	54	118	610	225	470	637	346	65	1	2
400	930	230	670	135	54	118	712	225	470	739	346	50	1	2
500	995	230	730	135	54	118	772	225	470	799	346	55	1	2
600	1085	230	825	135	54	118	867	225	470	894	346	50	1	2
700	1235	230	970	135	54	118	1012	225	470	1039	346	55	1	2
800	1530	230	1215	135	54	118	1257	225	470	1284	346	105	2	3
1000	1530	230	1255	135	54	118	1297	225	470	1324	346	65	2	4
1200	1795	250	1510	135	54	118	1552	240	490	1579	357	45	2	4
1400	1795	250	1510	135	54	118	1552	240	490	1579	357	45	2	4

TCRQ	A	B	C	D	E	F	G	H	I	J	K	M	Motor Num.	Fan Num.
400	930	250	670	135	54	160	712	245	490	739	357	50	1	2
500	995	250	730	135	54	160	772	245	490	799	357	55	1	2
600	1235	270	970	135	54	160	1012	270	515	1039	372	55	1	2
800	1530	270	1215	135	54	160	1257	270	515	1284	372	105	2	3

Caution:

- (1) In order to fix unit, besides nut, lock washer and flat washer on the bottom, a nut and washer is recommended on the top, to make the unit steadier when operating.
- (2) Due to the drain pans designed incline, fan coil casing should be installed level, to ensure proper drainage.
- (3) For concealed fan coil unit, on the back of the unit and beside of connection of the

pipe, there should be more than 50cm and dismantlable ceiling is recommended for servicing and maintenance.

Ceiling Concealed –High Pressure FCUs: TFM

On top of the TFM there are waist-shape apertures for suspender. Customers are advised to use full threaded screws flat washer, lock washer and nut to make the unit sturdy when in operation.

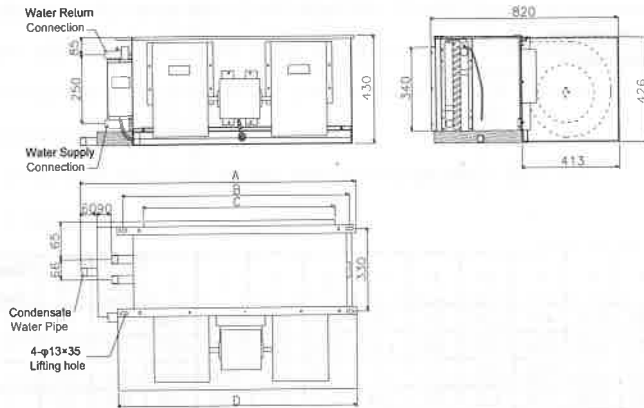

TFM	A	B	C	D	Inlet/Outlet Pipe	Condensate Water Pipe	Motor Quantity	Fan Quantity
800	860	683	530	653	R1	R1	1	1
1000	860	683	530	653	R1	R1	1	1
1200	960	783	630	653	R1	R1	1	1
1600	1110	953	800	753	R1	R1	1	2
1800	1260	1083	930	923	R1	R1	2	2
2000	1560	1403	1250	1373	R1 _{1/2}	R1	2	2
3000	2010	1853	1700	1823	R1 _{1/2}	R1	3	3

Caution:

- (1) In order to fix unit, besides nut, lock washer and flat washer on the bottom, a nut and washer is recommended on the top, to make the unit steadier when operating.
- (2) Due to the drain pans designed incline, fan coil casing should be installed level, to ensure proper drainage.
- (3) For concealed fan coil unit, on the back of the unit and beside of connection of the pipe, there should be more than 50cm and dismantlable ceiling is recommended for servicing and maintenance.

Ceiling Expose/Vertical Expose FCUs: TC

(1) Decide the open size of the ceiling according to the units.

(2) The choice of hanging base:

Hanging base should be the wooden frame and reinforced concrete frame that are firm, dependable and can bear 200kg or more weight. The hanging base should bear a certain weight for a long term. Before construction, please consult the constructor and decorator to confirm whether can install or not.

(3) The fixup of the bolt

Use the following method to fix the bolts or use hob and wooden frame to hang the bolt: ceiling, girder, beam, attic, hanging bolt M10 (3/8"), reinforcing steel bar, hook that can bear 120kg or more.

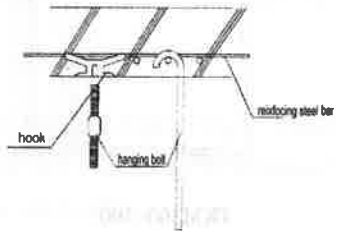

(4) Connection of the pipe

Connect chilled water pipe with the water outlet pipe of coil water 3/4 inch outer worm nut, the connector for water-in and water-out of the coil as drawing.

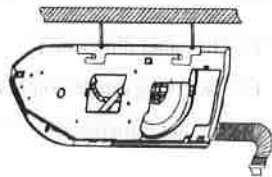

(5) Connection of the draining pipe

PVC pipe with 15mm inner diameter is needed and downward slanting angle should be above 2%; connect draining pipe with adhesive glue, and tie the PVC pipe; check every step of the connection.

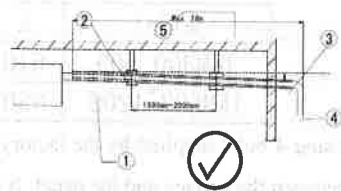

1) Heat insulation material

2) Draining pipe support

3) Mini slanting angle

4) Drainage pipe

5) Max distance of water

6) Up and fold (not allowed)

7) Air discharge port

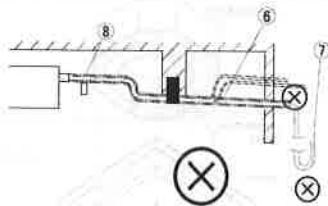

Cassette FCUs: TKM

Connection of the pipe

- (1) Cut the opening in the suspended ceiling to allow the fan coil to be inserted.
- (2) Position the tie rods and fix them to the load bearing structures.
- (3) Adjust the height of the unit and keep it horizontal using a leveling.

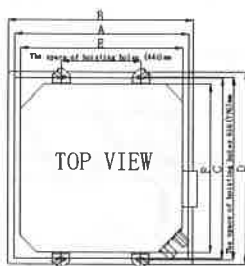

TKM300~500

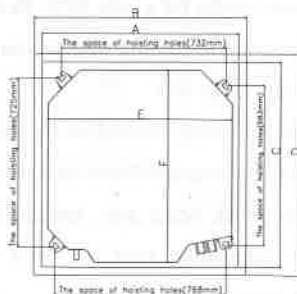

TKM600~1200

- B、D: The panel dimension
- A、C: The fixing dimension in the ceiling
- E、F: The unit dimension

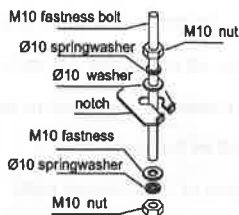

Model	A	B	C	D	E	F
TKM300~500	610	650	610	650	570	570
TKM600~1200	880	950	880	950	840	840

Using 4 bolts supplied by the factory to mount the front panel. Make sure there is no gap between the surface and the panel. It may cause the condensate water or air leakage.

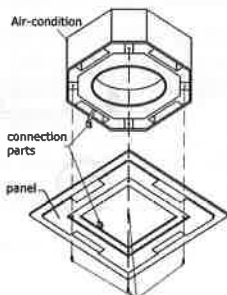

Fixing bolt for panel (M5x20 hexagon screw, washer, spring washer).

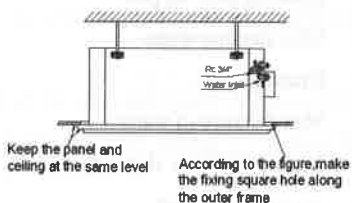

Drain pipe installation

The drain must be installed with a downward slope. The drain line should be insulated.

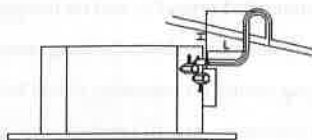

$$H \leq 300\text{mm};$$
$$L \leq 300\text{mm}$$

If the units share the common flexible hose, large diameter is needed in order to drain out condensate water.

Exhaust and pressure test of water pipes

If no water is present in the coil, before filling, open air valve, then begin filling to release any air inside the coil. This may cause noise within the coil. Once all the air is released and some water comes out of the air exhaust valve close valve tightly.

Before leaving the factory, all heat exchangers are examined for air-tightness under water with 2.8 MPa, which rated highest work pressure is 2.0 MPa. The test of pressure for water system must conform to test scheme carried out in advance, adding pressure slowly and equally, when pressure is stable, inspect each connection of pipeline carefully to see if there is leaking.

Caution:

The pressure test of the system and commission of the above must conducted in conditions with no frost (lowest temperature higher than 0°C), corresponding measure to prevent frost-damage must be taken, and otherwise, it may lead to permanent damage to the FCU

If leak is found, repairing with water pressure is not permitted; otherwise, it will lead permanent damage to FCU

Inspect before running

Before the units running, inspection procedures hereinafter must be completed:

- (1) All operating personnel read the handbook carefully.
- (2) Horizontal installation to ensure normal drainage.
- (3) The drain pan, coil and body are all cleaned properly.

- (4) Power supply of unit and controlled line of unit are all connected properly; wire of power supply connected properly; grounded properly.
- (5) Pipe of chilled water are connected properly, and no leaking after water pressure test.
- (6) Drainpipe is connected well, and no leakage; draining successfully
- (7) Impeller of units is all running easily, no jamming; filters are fixed well.
- (8) Inlet pipes, outlet pipe and drainpipes are all applied with proper thickness insulation, with no condensation.
- (9) Air conduit system of unit flow smoothly with no leaking.
- (10) The return air filter is installed properly.

Servicing and maintenance

Caution: Running machines and power source are dangerous, it can lead to injure or death!

Good-quality products need your meticulous maintenance to work with long-term stability!

Components	Maintenance	Advising times
Air-filter	<ol style="list-style-type: none"> 1. Clear it with the vacuum or gently flap. 2. Rinsing, drying, and then fixing it. 3. Don't use the gas, alcohol or any other chemicals. 	Two times every year, adding the times if necessary.
Panel	<ol style="list-style-type: none"> 1. Clear it with the duster or scrub with dishcloth soaked suds. 2. Don't use the gas, alcohol or any other chemicals. 	One time every month, adding the times if necessary.
Drain pan and drainage	Clear and inspect it, preventing jam.	Every quarter before the start.
Coil	Inspecting the work state, and clear the dust in its surface.	Every quarter before the start
Fan motor	Check the fan motor and capacitor, replace it if necessary.	Two times every year, adding the times if necessary.

Wiring diagram

Model for TCR/TCRQ/TFM

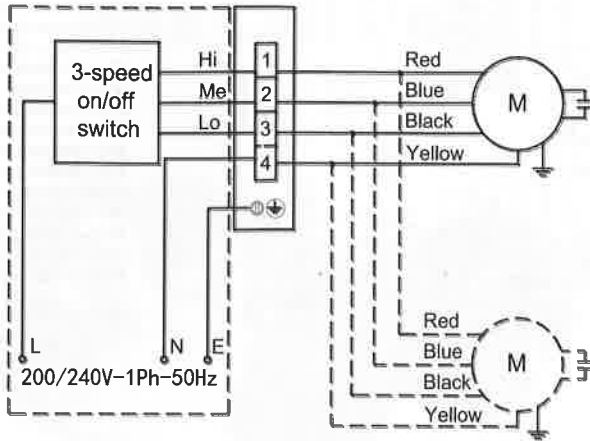

Model for TC

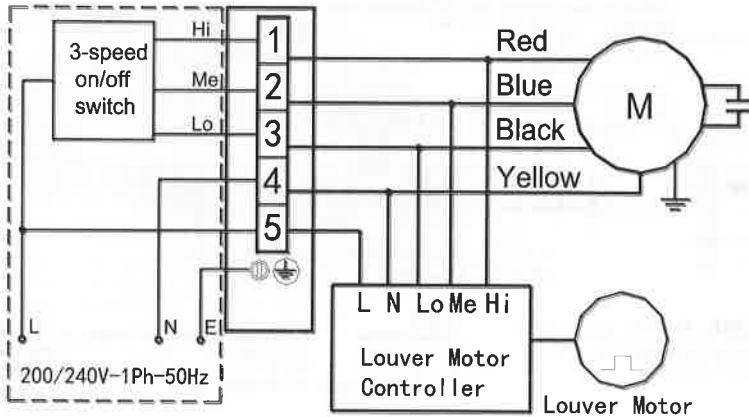

Model for TKM 300~500

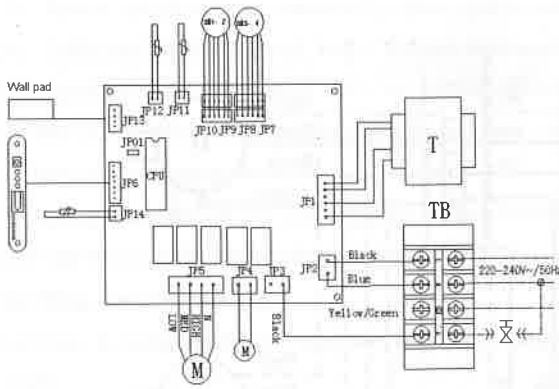

Legend:

- JP01—Open is with valve
 - Short is without valve
 - JP1—Transformer
 - JP2—Power supply
 - JP3—2-way valve
 - JP4—Drainage pump
 - JP5—Fan motor
 - JP6—Remote receiver
 - JP7—Stepping motor
 - JP8—Stepping motor
 - JP9—Stepping motor
 - JP10—Stepping motor
 - JP11—Room TEMP. sensor
 - JP12—Indoor coil TEMP. sensor
 - JP13—Wall pad
 - JP14—Float switch
- FACTORY WIRING
 - - - - - FIELD WIRING

Model for TKM 600~1000

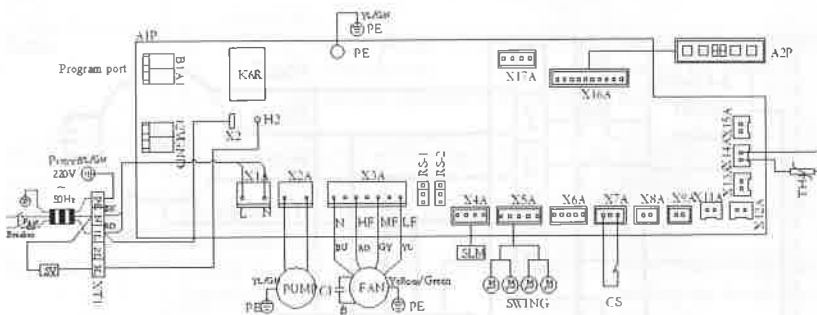

Note:

- 1 filed wiring, connector
- 2 Wiring only allows copper wire
- 3 Only provides the solenoid valve control port, except solenoid valve

Legend

- A1P—Controller
- PUM—Pump
- C1—Capacitor
- SLM—Remote control
- A2P—Receiving display circuit board
- FAN—Fan motor
- TH4—Ambient temperature
- SV—Solenoid valve
- XT 1—Terminal block
- SWING—Swing motor
- CS—Water level switch