



PRO
TICA PRO



Water-cooled Flooded Screw Chiller



Established in 1991

TICA is a professional enterprise specialized in R&D, manufacturing, sales and services of environment cleaning and thermal energy utilization.

TICA is a national high-tech enterprise, a single leading enterprise cultivated by the Ministry of Industry and Information Technology, a national brand cultivation enterprise of the Ministry of Industry and Information Technology, and a vice chairman member of China Refrigeration and Air-conditioning Industry Association. It has a national-recognized enterprise technology center, an enterprise academician workstation, and a post-doctoral research workstation. Its projects cover Beijing Bird's Nest Stadium, Water Cube, Wukesong Indoor Stadium, PetroChina, Sinopec, State Grid, Nanjing Panda, Hangzhou Xiaoshan International Airport, Hainan Airlines Group, Shangri-La Hotel, Manila Ocean Park, Abu Dhabi Al Muneera, SM City in Philippines and Unilever, etc.

TICA is also the outstanding provider of central air conditioners for China's subway networks and has successfully served nearly 60 key subway lines in major cities such as Beijing, Shanghai, Guangzhou, Shenzhen, Chengdu, Suzhou, Hangzhou and Tianjin. TICA is a professional supplier and service provider in China that specializes in system integration of clean environment. While for microelectronics, hospital operating rooms, biopharmaceutical industry and other professional purification areas, our market share has achieved over 40% in each.

TICA Quality For IAQ

TICA focuses on indoor air quality (IAQ) in clean environments. Product lines include return air purifiers, heat recovery ventilators, fresh air purifiers, air purifiers, as well as the clean air handling units and digital variable-capacity air handling units used in the professional purification field. Regarding core technology, TICA established an ISO class 1 super-clean environment integration system and won the first prize of CMIST.

TICA's product lines include modular chillers, VRF units, screw chillers, centrifugal chillers, and ORC low-temperature waste heat power generation systems. In 2015, TICA and United Technologies Corporation (UTC) established a global strategic joint venture cooperation relationship and acquired PureCycle, an ORC low-temperature power generation company owned by Pratt & Whitney under UTC. TICA obtained PureCycle trademarks and more than 100 patents and national copyrights. TICA's efficient centrifugal chillers, water-cooled screw chillers, and air-cooled screw chillers are manufactured with the technical license of Carrier under UTC.

TICA is characterized by excellent system integration capability. In the application of "Efficient Refrigeration System of Underground Railway Station", the integrated COP of the refrigeration room amounts to 6.0, and the research achievement reaches the international advanced level. In 2018, TICA merged and acquired an OFC central air conditioning enterprise **SMART**. TICA's excellent system integration capability and the **SMART** OFC water chillers help increase the integrated COP of the efficient equipment room to 6.7 to 7.0.

TICA---We're striving.

TICA aims to build itself into a world-leading system integration supplier and service provider that specializes in clean environment and thermal energy utilization.

Features	3
Technical Specifications	6
Technical Parameter Correction Factor Diagram	9
Options	10
Unit Dimensions	11

TICA owns five production sites in Nanjing, Tianjin, Guangzhou, Chengdu and Kuala Lumpur, and a network of over 70 sales and branches around the world.

Its Nanjing HQ base received 3-star certification for national No. 001 green industrial construction.



Malaysia Base



Nanjing Headquarter



Tianjin Base



Guangzhou Base



Chengdu Base

Water-cooled Flooded Screw Chiller



TICA water-cooled flooded screw chiller adopts a compact design and is equipped with the flooded evaporator, semi-hermetic double-screw compressor and high efficient heat exchanger. Together with the advanced microcomputer control technology, the chiller is highly stable and reliable, and features efficient and quiet operations. Available in a variety of models, the units are ideal for scenarios requiring comfort and process cooling.

Nomenclature

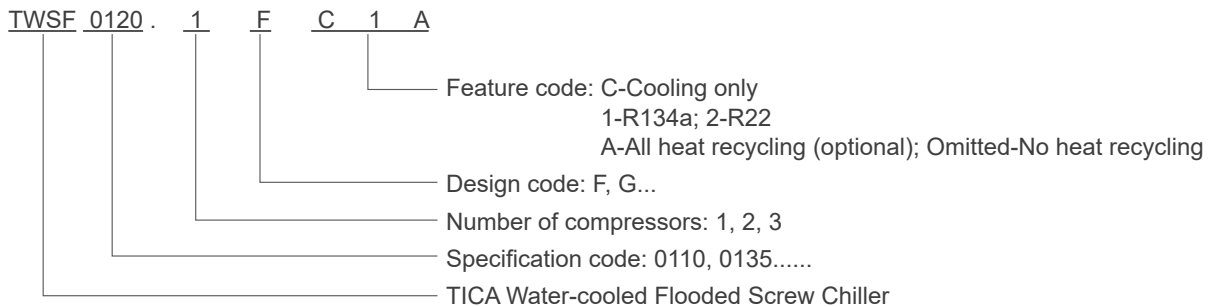

Features



Internationally Recognized Quality

The units have passed the certification of the Air-Conditioning, Heating and Refrigeration Institute (AHRI).

The units are up to the AHRI551/991-2011 standard (AHRI is considered to be the most prestigious organization in the international refrigeration industry).

Both TICA unit performance test bench and independently developed unit selection software have passed the AHRI certification. Every unit has to pass the test on the test bench recognized by AHRI before delivery. TICA laboratory has obtained national CNAS certification.

High-efficiency compressor

Efficient German compressor

- ◆ The double-screw compressor special for German patented water-cooled unit boasts high adiabatic efficiency. The high-efficiency and large-capacity motor helps significantly reduce power consumption of the unit, enabling the unit to operate efficiently in full load or partial load.
- ◆ The three-stage oil separator of the compressor works with efficiency up to 99.5%.
- ◆ With the stepless regulation of the slide valve, a single compressor can match 25%–100% load change, and a dual head unit can implement 12.5%–100% load change.
- ◆ The screw rotor is processed with patented technology, and its micron-level precision ensures precise engagement and long service life.
- ◆ The compressor motor cools down by air suction to ensure long service life, and the complete protection function guarantees safe operation of the unit.

High-efficiency heat exchanger

- ◆ The shell-and-tube type, flooded evaporator features newly arranged and enhanced bilateral heat exchange tubes to guarantee efficient heat exchange; uses CFD simulation to calculate and design liquid baffle to balance the air field, ensuring liquid level stability, and absorbing air only instead of liquid and guaranteeing stable operation.
- ◆ The shell-and-tube type condenser features built-in TICA's patented oil separator, allowing the oil separation efficiency to be up to 99.9% combined with the compressor embedded oil separator; uses CFD simulation to calculate and analyze sub-cooling part, and increases the refrigerant's supercooling degree by 2-3 times, ensuring that liquid supply pipes are free of gaseous refrigerant and the unit operates efficiently and reliably.
- ◆ The detachable lid makes it easy to cleanse the inside of heat exchange tubes, thereby ensuring high efficiency of heat exchanging.

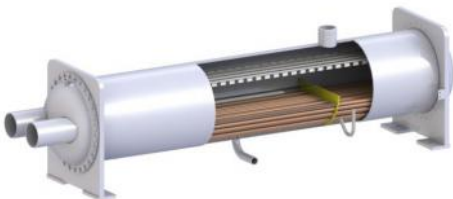
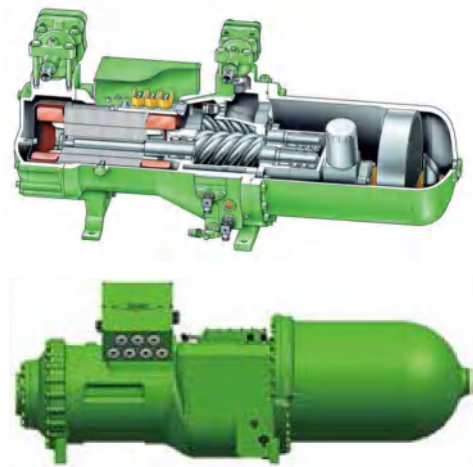

Electronic expansion valve

- ◆ The sophisticated EXV features accurate control, fast speed of response, and a wide range of regulation, allowing the unit to operate reliably whether under full load or partial load.



Unique oil return

- ◆ The continuous oil return technology – oil injected by oil – adopts the cutting-edge, special injection pump to inject the remaining 0.1% oil in the evaporator into the compressor to ensure safe and reliable running of the compressor.
- ◆ With TICA's patented technology of automatic oil injection, the system will automatically start oil-injection control program when the oil level in the compressor reaches the low limit, ensuring the compressor's safe and efficient operation.

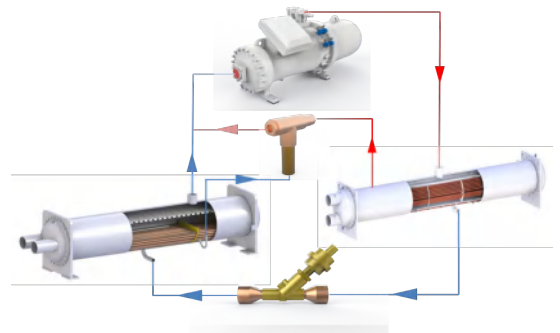

Convenient installation

- ◆ Both the evaporator and condenser are configured with flanges and clamps to make field installation convenient.
- ◆ The unit requires a small floor area due to the compact structure.
- ◆ The refrigerant water flow ranges from 40% to 110% of the nominal flow, making it more suitable for flow variable primary pump.
- ◆ The unit is configured with a compressor startup cabinet, to facilitate on-site cable connection by the user.
- ◆ The unit is properly insulated.
- ◆ With minimal vibration, the unit is equipped with 4 pieces of 30mm chloroprene rubber shock-absorbing cushions.
- ◆ Sufficient refrigerant has been charged in the unit before the entire unit is delivered.
- ◆ During installation on site, users only need to connect the water pipes of evaporator and condenser and connect the power supply.



Precise Control System and Reliable Operation



◆ Sophisticated control system
 —The industrial-level microcomputer controller, together with the 7-inch colored touch screen, constitutes the control unit of the unit. As a result, the unit is rather reliable and jamproof and therefore ideal for complicated, hostile working environments.

◆ Unique dynamic optimization and control algorithms
 —Benefiting from TICA's years of experience in air conditioning design and application, the control algorithms feature more precise calculation of unit load; the algorithms are integrated with TICA's unique dynamic optimization and control to allow the units to make adjustments in all operating conditions and to ensure the units are keeping running in an efficient, reliable and secure manner; The refrigerant water flow ranges from 40% to 110% of the nominal flow, making it more suitable for flow variable primary pump.



◆ Intelligent control
 —The advanced pre-control function enables measures to be taken promptly before actual failure occurs to avoid unexpected shutdown of the unit due to an alarm.

—Multiple compressors can operate automatically to reach a load balance and therefore can prolong the service life of the unit.

—Each compressor and circuit can be controlled independently and can serve as the standby for another compressor, minimizing the impact of possible faults.

—Unique oil return control technology resolves the issue of oil separation.

—Benefiting from the fuzzy control technology, the unit is able to adjust the water temperature based on outdoor air temperature and hence can enhance efficiency to the greatest extent while meeting the needs.

—The unit supports the compiling of weekly operating schedules to implement comprehensive automatic start and stop control of the unit, and can truly be left unattended.

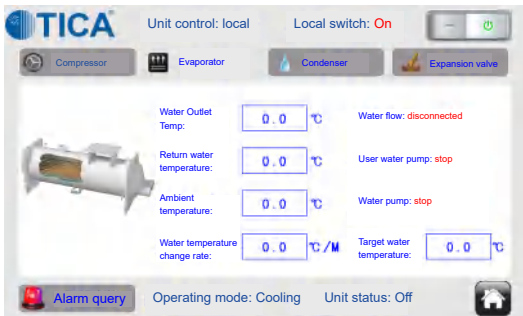

◆ Complete safety protection

—Power supply protection: phase loss, reverse phase, over-voltage, and under-voltage

—Compressor protection: protection for motor overheat, overload, frequent startup, oil level and high discharge temperature

—Pressure protection: both evaporator and condenser are equipped with safety valves, and have protection when low pressure is too low, high pressure is too high, and protection for low air suction/discharge pressure difference.

—Other protection: too low water temperature protection, too low water flow protection, sensor failure protection, etc.

Flexible and convenient group communication

—Standard RS485 interface and MODBUS RTU protocol are provided, and the unit is connected to the building automation system (BAS), which implements centralized control and remote monitoring of the unit and control of other attached devices according to the controlling requirement of the BAS.

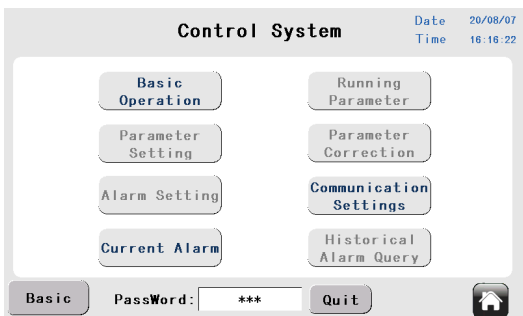

Technical Specifications

High-efficiency series

Model		TWSF-FC1	0110.1	0135.1	0160.1	0175.1	0200.1	0220.1	0240.1	0265.1
Capacity	Ton		110	135	156	175	200	215	235	260
	kW		387	475	547	615	703	755	825	915
Power input	kW		65	80	91	102	116	125	136	151
Efficiency	kW/Ton		0.591	0.592	0.583	0.583	0.580	0.582	0.580	0.580
COP	W/W		5.95	5.94	6.01	6.03	6.06	6.04	6.07	6.06
Compressor quantity	Set		1	1	1	1	1	1	1	1
Power supply		380V 3N-50Hz(460V 3N-60Hz)								
Refrigerant		R134a								
Energy control		Stepless regulation of energy								
Evaporator	Design pressure on water side	Mpa	1.0							
	Water flow	m ³ /h	67	82	94	106	121	130	142	157
	Water pressure drop	kPa	74	72	73	72	73	74	75	86
	Piping DN	mm	150	150	150	150	150	150	150	150
	Connection Type		victaulic coupling							
Condenser	Design pressure on water side	Mpa	1.0							
	Water flow	m ³ /h	78	96	110	123	141	151	165	183
	Water pressure drop	kPa	86	77	87	86	85	72	78	68
	Piping DN	mm	150	150	150	150	200	200	200	200
	Connection Type		victaulic coupling							
Dimensions	Length	mm	3122	3122	3122	3122	3144	3144	3144	3144
	Width	mm	1500	1500	1500	1500	1550	1550	1550	1550
	Height	mm	1800	1800	1800	1800	1850	1850	1850	1850
Shipping weight		kg	2750	3200	3250	3350	3800	3850	4000	4150
Operating weight		kg	2950	3450	3490	3590	4150	4180	4400	4500

★ **Note:**

1. The parameters under above operating conditions: are as follows: chilled water outlet temperature 7°C, chilled water inlet temperature 30°C.
2. For technical parameters under non-standard operating conditions, please contact TICA.
3. The maximum startup current listed in the table is the current under Y- Δ startup mode.
4. Power supply: 380V 3N-50Hz; allowable voltage fluctuation: $\pm 10\%$.
5. Standard water vessels pressure: 1.0 MPa.
6. Specification parameters are subject to change without prior notice, due to product improvement.

High-efficiency series

Model	TWSF-FC1	0280.2	0300.2	0325.2	0350.2	0370.2	0390.2	0410.2	0430.2	0450.2	0465.2	0495.2	0510.2	
Capacity	Ton	277	293	316	340	367	392	409	425	441	461	486	507	
	kW	973	1030	1110	1194	1292	1379	1438	1495	1551	1620	1710	1782	
Power input	kW	161	171	184	198	215	228	238	245	255	267	281	293	
Efficiency	kW/Ton	0.582	0.584	0.583	0.583	0.585	0.581	0.582	0.576	0.578	0.579	0.578	0.578	
COP	W/W	6.04	6.02	6.03	6.03	6.01	6.05	6.04	6.10	6.08	6.07	6.09	6.08	
Compressor quantity	Set	2	2	2	2	2	2	2	2	2	2	2	2	
Power supply	380V 3N-50Hz(460V 3N-60Hz)													
Refrigerant	R134a													
Energy control	Stepless regulation of energy													
Evaporator	Design pressure on water side	Mpa	1.0											
	Water flow	m ³ /h	167	177	191	205	222	237	247	257	267	279	294	307
	Water pressure drop	kPa	65	80	72	80	66	65	72	57	63	63	63	62
	Piping DN	mm	200	200	200	200	200	200	200	200	200	200	200	200
	Connection Type	victaulic coupling												
Condenser	Design pressure on water side	Mpa	1.0											
	Water flow	m ³ /h	195	207	223	240	259	276	288	300	311	325	343	357
	Water pressure drop	kPa	65	83	83	85	57	56	86	56	59	61	60	62
	Piping DN	mm	200	200	200	200	200	200	200	200	200	200	200	200
	Connection Type	victaulic coupling												
Dimensions	Length	mm	4497	4497	4497	4497	4540	4540	4540	4540	4540	4624	4624	4652
	Width	mm	1600	1600	1600	1600	1800	1800	1800	1800	1800	1800	1800	1800
	Height	mm	1950	1950	1950	1950	2050	2050	2050	2050	2050	2050	2050	2050
Shipping weight	kg	6500	6550	6650	6750	7100	7200	7250	7350	7500	7600	7750	7800	
Operating weight	kg	6970	7000	7150	7250	7800	7900	7950	8100	8250	8350	8575	8600	

★ **Note:**

1. The parameters under above operating conditions: are as follows: chilled water outlet temperature 7°C, chilled water inlet temperature 30°C.
2. For technical parameters under non-standard operating conditions, please contact branches of TICA.
3. The maximum startup current listed in the table is the current under Y- Δ startup mode.
4. Power supply: 380V 3N-50Hz; allowable voltage fluctuation: $\pm 10\%$.
5. Standard water vessels pressure: 1.0 MPa.
6. Specification parameters are subject to change without prior notice, due to product improvement.

Super high-efficiency series

Model	TWSF-FC1	0430.1	0450.1	0470.1	0850.2	0900.2	0940.2	
Capacity	Ton	429	450	469	854	895	933	
	kW	1509	1581	1648	3002	3148	3279	
Power input	kW	239	250	259	475	496	516	
Efficiency	kW/Ton	0.557	0.556	0.553	0.556	0.554	0.553	
COP	W/W	6.31	6.32	6.36	6.32	6.35	6.35	
Compressor quantity	Set	1	1	1	2	2	2	
Power supply	380V 3N-50Hz(460V 3N-60Hz)							
Refrigerant	R134a							
Energy control	Stepless regulation of energy							
Evaporator	Design pressure on water side	Mpa	1.0					
	Water flow	m ³ /h	260	272	284	516	541	564
	Water pressure drop	kPa	60	45	40	60	60	70
	Piping DN	mm	200	200	200	250	250	250
	Connection Type	Victaulic coupling						
Condenser	Design pressure on water side	Mpa	1.0					
	Water flow	m ³ /h	301	315	328	598	627	653
	Water pressure drop	kPa	40	45	40	80	80	70
	Piping DN	mm	250	250	250	300	300	300
	Connection Type	victaulic coupling						
Dimensions	Length	mm	4800	4800	4800	6700	6700	6700
	Width	mm	2260	2260	2260	2700	2700	2700
	Height	mm	2600	2600	2600	2750	2750	2750
Shipping weight	kg	7800	8300	8800	13000	14000	15000	
Operating weight	kg	8970	9500	10100	14950	16000	17000	

★ **Note:**

1. The parameters under above operating conditions are as follows: chilled water outlet temperature 7°C, chilled water inlet temperature 30°C.
2. For technical parameters under non-standard operating conditions, please contact branches of TICA.
3. The maximum startup current listed in the table is the current under Y- Δ startup mode.
4. Power supply: 380V 3N-50Hz; allowable voltage fluctuation: $\pm 10\%$.
5. Standard water vessels pressure: 1.0 MPa.
6. Specification parameters are subject to change without prior notice, due to product improvement.

Technical Parameter Correction Factor Diagram

Cooling capacity correction factor diagram of the water-cooled flooded screw chiller

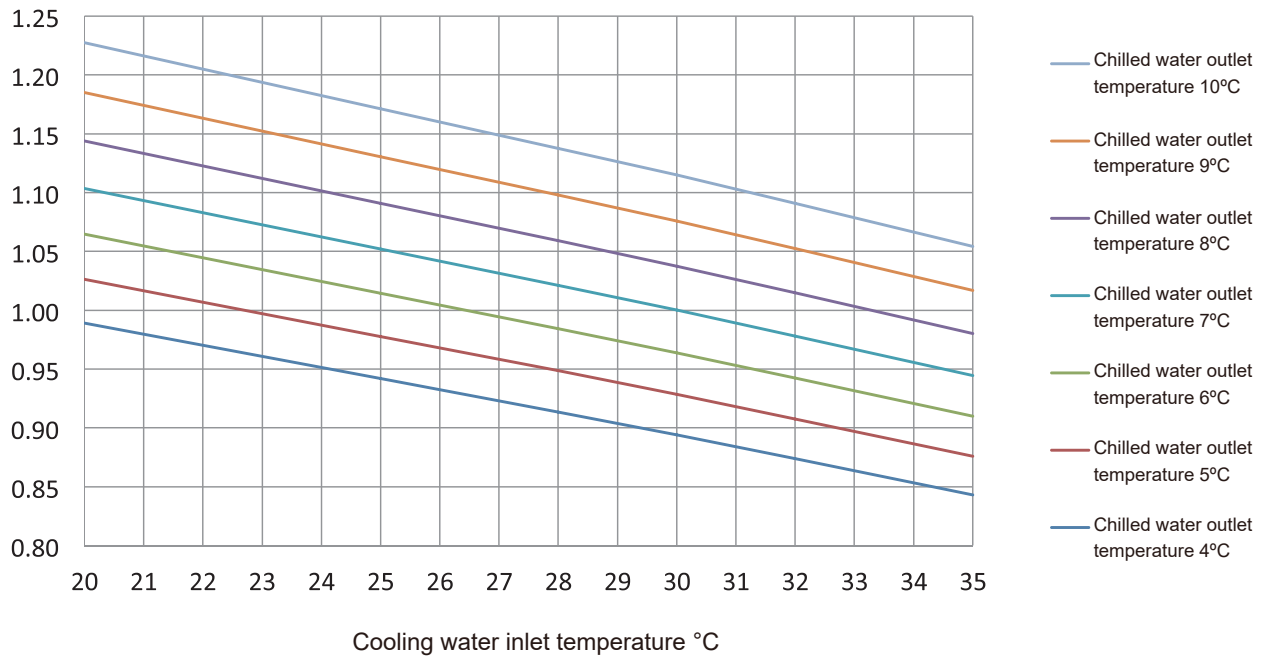

Input power correction factor diagram of the water-cooled flooded screw chiller

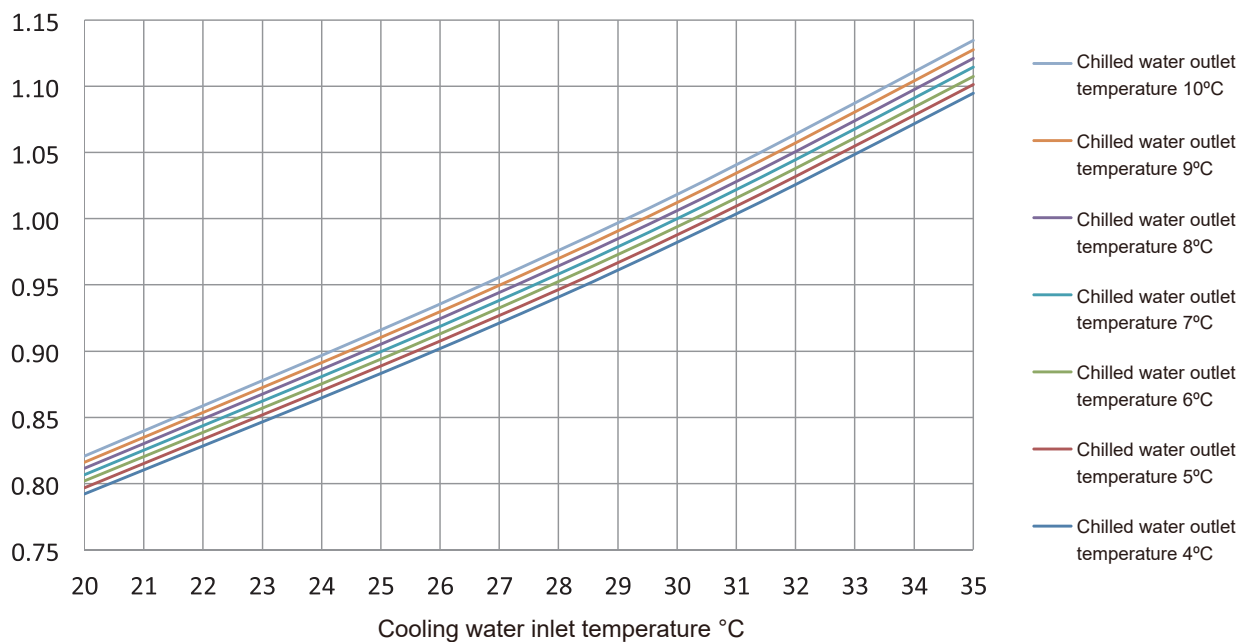

Options

1. Electric control	
Circuit breaker, soft start, start by inverter, remote monitoring, remote operation screen, and PLC control (Siemens)	
2.Vessels	
Tube connection direction (Facing control cabinet)	Right
Water-side Pressure	1.6MPa, 2.0MPa
Connection Type	Flange connection
3. Others	
Damping device	Spring shock-absorbing cushions
Chiller insulation	40mm rubber and plastic insulation material
Chiller package	Ordinary wooden box, fumigated wooden box
Bottom channel steel	Yes

Unit Dimensions

—One Compressor high-efficiency series

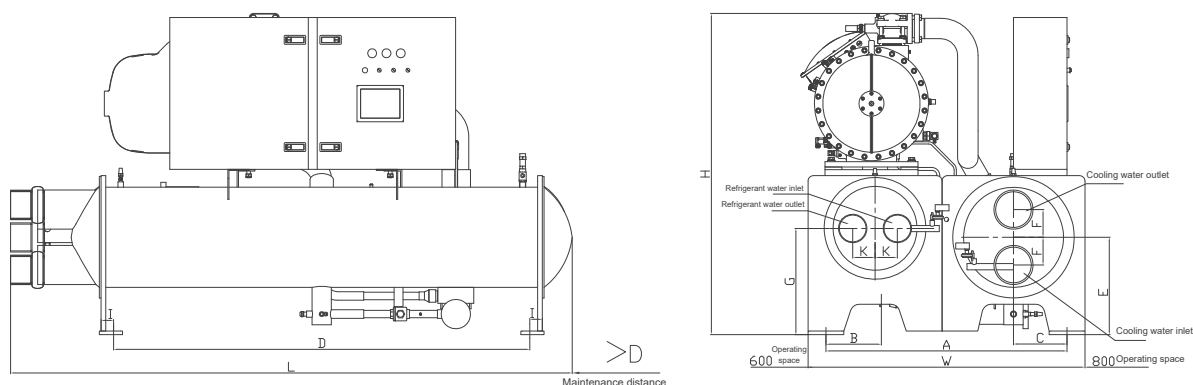

Model (TWSF-FC1)	Evaporator water inlet/outlet	Condenser water inlet/outlet	A	B	C	D	E	F	G	L	W	H	K	I
0110.1	DN150	DN150	1300	275	275	2330	495	125	595	3122	1500	1800	125	70
0135.1	DN150	DN150	1300	275	275	2330	495	125	595	3122	1500	1800	125	
0160.1	DN150	DN150	1300	275	275	2330	495	125	595	3122	1500	1800	125	
0175.1	DN150	DN150	1300	275	275	2330	495	125	595	3122	1500	1800	125	
0200.1	DN150	DN200	1350	275	300	2330	545	155	595	3144	1550	1850	125	
0220.1	DN150	DN200	1350	275	300	2330	545	155	595	3144	1550	1850	125	
0240.1	DN150	DN200	1350	275	300	2330	545	155	570	3144	1550	1850	130	
0265.1	DN150	DN200	1350	275	300	2330	545	155	570	3144	1550	1850	130	

★ **Note:**

1. The water inlet and outlet pipes of evaporator and condenser must be supported to avoid applying any external force to the unit.
2. The size of the equipment room area can guarantee repair and maintenance of the evaporator and condenser.

—Double compressors high-efficiency series

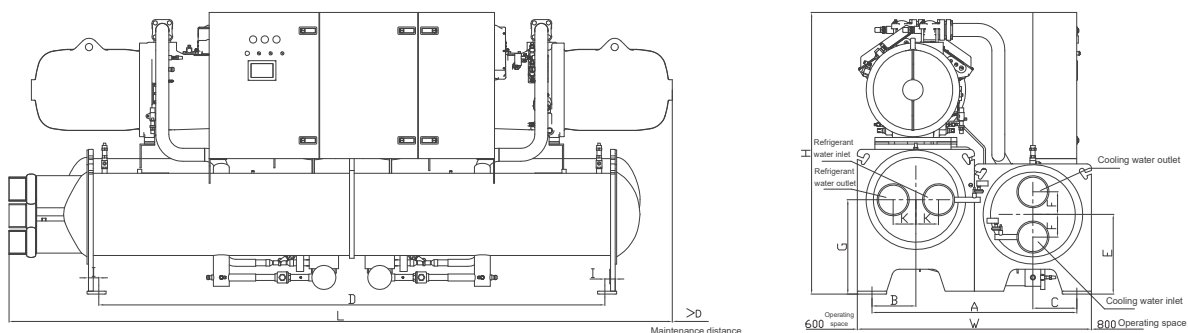

Model (TWSF-FC1)	Evaporator water inlet/outlet	Condenser water inlet/outlet	A	B	C	D	E	F	G	L	W	H	K	I
0280.2	DN200	DN200	1400	300	300	3460	545	155	645	4497	1600	1950	155	70
0300.2	DN200	DN200	1400	300	300	3460	545	155	645	4497	1600	1950	155	
0325.2	DN200	DN200	1400	300	300	3460	545	155	645	4497	1600	1950	155	
0350.2	DN200	DN200	1400	300	300	3460	545	155	645	4497	1600	1950	155	
0370.2	DN200	DN200	1600	350	350	3460	595	180	695	4540	1800	2050	180	
0390.2	DN200	DN200	1600	350	350	3460	595	180	695	4540	1800	2050	180	
0410.2	DN200	DN200	1600	350	350	3460	595	180	695	4540	1800	2050	180	
0430.2	DN200	DN200	1600	350	350	3460	595	180	695	4540	1800	2050	180	
0450.2	DN200	DN200	1600	350	350	3460	595	180	695	4540	1800	2050	180	
0465.2	DN200	DN200	1600	350	350	3460	595	180	695	4624	1800	2050	180	
0495.2	DN200	DN200	1600	350	350	3460	595	180	695	4624	1800	2050	180	
0510.2	DN200	DN200	1600	350	350	3460	595	180	695	4652	1800	2050	180	

★ **Note:**

1. The water inlet and outlet pipes of evaporator and condenser must be supported to avoid applying any external force to the unit.
2. The size of the equipment room area can guarantee repair and maintenance of the evaporator and condenser.

—One Compressor super high-efficiency series

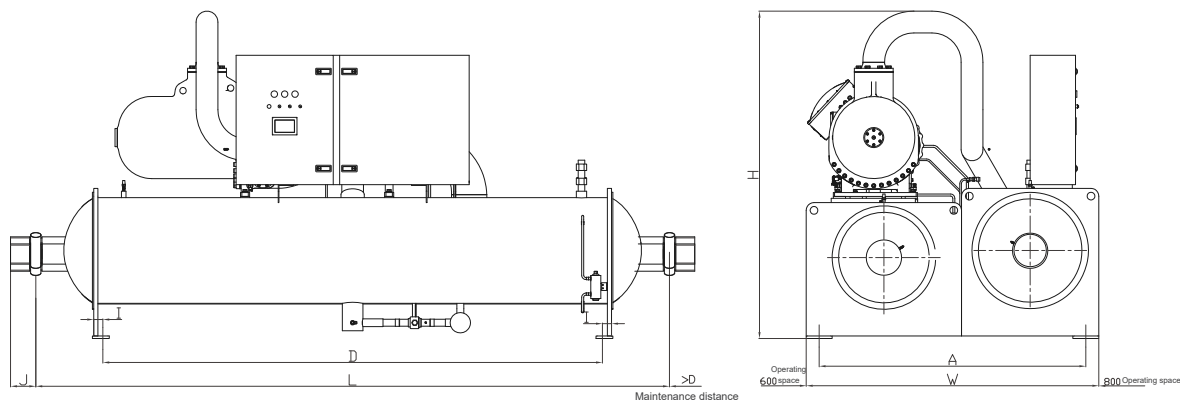

Model (TWSF-FC1)	Evaporator water inlet/ outlet	Condenser water inlet/ outlet	A	D	L	W	H	I	J
0430.1	DN200	DN250	2060	3460	4800	2260	2600	70	200
0450.1	DN200	DN250	2060	3460	4800	2260	2600		
0470.1	DN200	DN250	2060	3460	4800	2260	2600		

—Double compressors super high-efficiency series

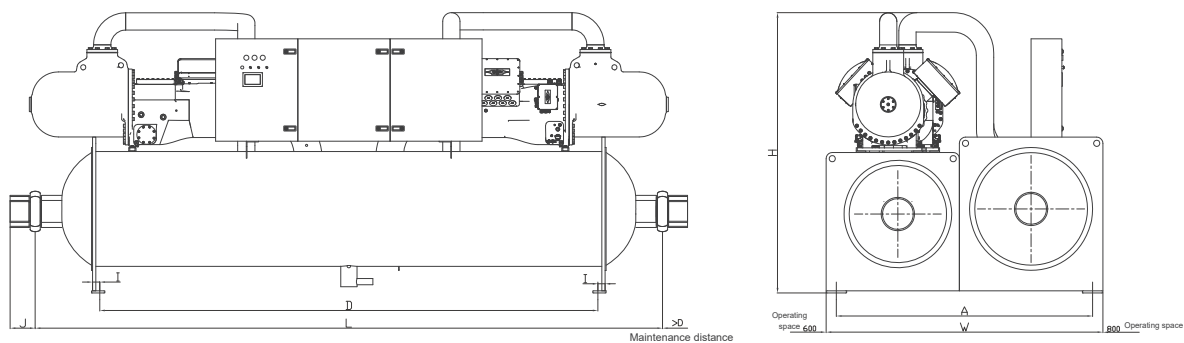

Model (TWSF-FC1)	Evaporator water inlet/ outlet	Condenser water inlet/ outlet	A	D	L	W	H	I	J
0850.2	DN250	DN300	2500	5360	6700	2700	2750	70	200
0900.2	DN250	DN300	2500	5360	6700	2700	2750		
0940.2	DN250	DN300	2500	5360	6700	2700	2750		

★ **Note:**

1. The water inlet and outlet pipes of evaporator and condenser must be supported to avoid applying any external force to the unit.
2. The size of the equipment room area can guarantee repair and maintenance of the evaporator and condenser.



«TICA PRO» LLC
Tel. +7 495 127 79 00
E-mail: info@tica.ru
<http://en.tica.pro>
