

INSTALLATION & OPERATION MANUAL

**MODULAR AIR-COOLED
CHILLER (HEAT PUMP)**

TCA

Contents

I. Overview.....	3
II. Safety Precautions.....	5
III. Unit Description.....	7
1. Scope of Application, Purposes and Characteristics.....	7
2. Standard Compliance.....	8
IV. Specifications.....	10
1. Model Nomenclature.....	10
2. Technical Specifications.....	10
3. Structure Diagrams.....	14
V. Unit Installation.....	16
1. Key Points for Installation.....	16
2. Installation Diagrams.....	16
3. Unit Installation.....	21
4. Installation of the Water System.....	22
5. Electrical Installation.....	31
VI. Unit Commissioning and Operation Description.....	44
VII. Operation Description of the Unit Controller.....	46
1. Safety Precautions.....	46
2. Application Scope.....	47
3. System Characteristics.....	47
4. Unit Operation Description.....	48
VIII Unit Maintenance.....	55
IX. Common Fault Analysis of the Unit and Handling Methods.....	56
X. After-sales Service.....	59
XI. Other Information.....	60
1. Installation of the Remote Controller.....	60
2. Auxiliary Electric Heater.....	62
3. Interlock Controller.....	65

4. Installation Description of the Main Water Outlet Temperature Sensing Probe.....	65
5. Description of the Connection Between the Temperature Sensing Probe/Water Pump and the Chiller.....	66
6. Environmental Protection Description.....	67

I. Overview

This manual is the customer's property and should be used together with the unit. After work, put the manual back in the technical documentation bag and keep it properly.

Please read through this manual carefully before installing the air conditioning unit, and install and maintain the unit according to the manual, ensuring normal and reliable operation of the unit. Only professionals appointed by company can install the air conditioning unit. The vendor shall not bear any responsibility if any unqualified operator installs or maintains the unit or the unit is not installed or operated according to requirements of this manual.

This manual does not cover the differences between various units or all the problems that may be met during installation, so it is impossible for it to provide instructions to all the situations that may occur during installation. If the buyer wants to get further information or meets a special problem but a detailed explanation is not provided in this manual, please contact company.

The prompts of "**Danger**", "**Warning**", and "**Caution**" are provided at proper parts in this manual. To ensure personal safety and normal operation of the unit, read through the content carefully and observe the related requirements.

 **Danger:** The prompt points out the potential hazard situation. Ignoring it may lead to death or serious personal injury.

 **Warning:** The prompt points out the potential hazard situation. Ignoring it may lead to minor or moderate personal injury. This prompt is also used for warning of unsafe activities.

 **Caution:** The prompt points out the potential situation of equipment damage.

Ignoring it may lead to equipment damage or property loss or possible environmental pollution. It also provides useful help information, which may be good to unit operation or extension of the unit service life. However, it does not indicate that the help information is optimal or is directly related to the improvement of unit operation.

 **Danger**

Prior to installation or maintenance, lock the unit power supply and disconnecting switch in the power-off state, avoiding personal casualties caused by electric shock or contact with a moving part. All the installation procedures of the air conditioning unit must comply with the national, provincial, and local regulations.

Warning

- 1. Do not use unqualified refrigerant, refrigerant substitute or refrigerant additive. Incorrect using method or using unqualified refrigerant, refrigerant substitute or refrigerant additive will lead to unit damage and various safety hazards. Please select qualified refrigerant or call the 400 hotline to purchase qualified refrigerant. All the technicians operating refrigerant must have acquired qualification certificates, and know very well and strictly observe the technical requirements, laws and regulations related to refrigerant use, handling, recovery, and recycling.**
- 2. If the ambient temperature is lower than 5°C and the unit is not used for a long time or a power failure occurs, be sure to thoroughly drain water from the unit and pipeline, and then disconnect the unit from the power supply. If the ambient temperature is lower than 5°C and the unit is not used temporarily, ensure that the unit is in the power-up state and the chilled water circulating pump of the air conditioner must be interlocked with the modular chiller. In this way, the modular unit can automatically control the water pump operation or heating operation, thereby implementing automatic anti-freezing protection of the air conditioning water system. The purpose is to protect facilities such as the unit and water pipeline against damage caused by freezing of water in the pipeline of the air conditioning water system.**
- 3. This appliance can be used by children aged from 8 years and above and persons with reduced physical, sensory or mental capabilities or lack of experience and knowledge if they have been given supervision or instruction concerning use of the appliance in a safe way and understand the hazards involved. Children shall not play with the appliance. Cleaning and user maintenance shall not be made by children without supervision.**
- 4. That the appliance shall be installed in accordance with national wiring regulations.**

II. Safety Precautions

- ◆ **Before operating the unit, read all the items in "Safety Precautions" carefully.**
- ◆ **"Safety Precautions" lists all important items related to safety. To prevent electric shocks, fire and other possible injuries, be sure to bear in mind and strictly abide by the following rules:**

- ◆ Install a leakage circuit breaker.
- ◆ The user cannot try to install the unit independently. Improper installation may lead to water leakage, electric shock, or fire.
- ◆ Be sure to install the grounding wire, which cannot be connected to the gas pipe, tap water pipe, lightning arrester, etc. Improper installation of the grounding wire easily leads to an electric shock accident.
- ◆ Be sure to make a foundation platform before installing the unit to ensure stable operation of the unit.
- ◆ Use the accessories specified by company and ask the manufacturer or authorized distributor to provide installation and technical services.
- ◆ The main controller must adopt the same power supply system together with the unit.
- ◆ The control data line must be separated from the power cord of power supply to prevent interference.
- ◆ Do not insert your fingers or other objects into the air outlet or inlet, lest you would be injured or the air conditioner would be damaged. The fan running at a high speed is very dangerous. Prevent kids from getting close to the fan.
- ◆ Do not damage the power cord or turn on/off the air conditioner by inserting/pulling out the power plug.
- ◆ Do not use water to flush the air conditioner directly; otherwise electric shock or other accidents are easily caused.
- ◆ Ensure smooth air inlet and outlet of the air conditioner.
- ◆ Do not turn on/off the air conditioner frequently; otherwise the air conditioner may be damaged due to frequent startup.
- ◆ If the unit will stop operation for a long term or in winter, drain the water from the system and then turn off the power supply.
- ◆ If the unit is not used temporarily in winter, ensure that the unit is in the power-up state to prevent unit freezing.
- ◆ If the unit will be used again after stop for a long term, first connect the power supply for the unit for preheating for 24 h.

- ⚠ The user cannot try to repair the unit independently. Improper repair may lead to an operation failure or burnout of the unit. To have the unit repaired, the user needs to contact the local branch or authorized maintenance service provider.

Caution

When charging or adding refrigerant to the unit, make sure that the charging amount and refrigerant type are consistent with the information on the unit nameplate. A refrigerant charging mistake may lead to a unit fault or other potential safety hazards.

Acid, alkali, salt spray and other corrosive gases will damage the unit casing, pipeline or electrical components. The unit installation position must be far away from the site with corrosive gases.

The circulating water pump of the water system must be interlocked with the main control board of the unit. Otherwise, commissioning and acceptance cannot be performed. Company will not bear any responsibilities for the incurred damage of the water-side heat exchanger and other accidents.

III. Unit Description

1. Scope of Application, Purposes and Characteristics

The modular air-cooled chiller (heat pump) uses the innovative modular design. The entire unit is composed of one or more modules, each of which consists of two or four independent cooling systems. The electric controllers of modules are independent of each other and modules are connected through communication cables to form a control network.

Modular air-cooled chillers (heat pumps) can be widely applied in new and restructured Industrial and civil construction projects, such as hotels, shopping malls, office buildings, entertainment centers, theaters, stadiums, plants, hospitals, high-grade apartments, and industrial cooling sites. Modular air-cooled chillers (heat pumps) do not need dedicated equipment rooms and cooling towers, and therefore, they become the optimal choice for Central Business Districts (CBDs) and water-stressed regions.

The unit has the following features:

High efficiency, energy saving, and reliable performance

The unit uses efficient scroll compressors and world famous excellent cooling parts, to ensure

the maximum energy efficiency of the unit. The modular combination design allows the unit to automatically lower the load in the case of partial loading, thereby achieving energy-efficient operation.

High-precision EXVs for throttling

The unit uses Electronic Expansion Valves (EXVs) as fine and adaptive control components for refrigerants, to implement dynamic matching between the refrigerant and compressor for the cooling system. This fully improves the optimum efficiency of every component in the system and ensures the best operation pressure and temperature for the system.

Support for connection to the building automation system

The unit is equipped with RS485 interfaces for connecting to the centralized building control system. It can be integrated into the centralized building control system via legitimate protocols, to implement building automation.

Convenient installation

The compact air-cooled heat pump modular machine can be placed on roofs, spacious balconies, and other appropriate open spaces, which saves installation space. In addition, cooling towers, cooling water pumps, boilers, and relevant pipes are not required, making the installation of the entire central air conditioner easier.

Intelligent defrosting

The unit automatically determines the optimal defrosting time based on the ambient temperature and actual operation parameters, to prevent frost residue or frequent defrosting. In addition, intelligent defrosting can prevent air conditioning effect from being affected by large water supply temperature fluctuation during unit defrosting.

Multi-protection design

The modular design allows starting the unit in a hierarchical way, reducing the impact of the startup current on the power grid.

The unit is equipped with multiple types of protection, including compressor overload protection, water shortage protection, system overpressure protection, system under-pressure protection, compressor exhaust over-temperature protection, frequent unit startup protection, external interlock protection, water outlet under-temperature protection, and automatic winter anti-freezing protection.

Microcomputer control system

The microcomputer control system uses microcomputer centralized control to implement combined installation and control of multiple modular units. A single controller can control a maximum of 16 units, making the unit operation and management more convenient. The microcomputer control system has the following functions:

- Timed power-on/off, which allows setting the weekends and three holiday time periods for the unit operation.
- Automatic fault judgment, handling, and alarm display.
- Operation and control of auxiliary electric heaters for heat pump units in winter.
- Intelligent defrosting control and intelligent anti-freezing operation control.
- Fuzzy control and balanced operation of compressors to implement optimal load matching.
- Password protection permissions for parameter settings.
- Fan coil unit interlock control function.

Wide operation range

The unit can run at an ambient temperature as high as 48°C in cooling mode and at an ambient temperature as low as -15°C in heating mode. Low temperature unit can run at an ambient temperature as low as -26°C, low temperature and high heating unit TCA401YHE can run at an ambient temperature as low as -30°C.

2. Standard Compliance

The unit complies with the national product standard GB/T 18430.1 Water Chilling (Heat Pump) Packages Using the Vapor Compression Cycle Part 1: Water Chilling (Heat Pump) Packages for Industrial & Commercial and Similar Application. TCA401YHE complies with the national product standard GB/T 25127.1-2020 Low ambient temperature air source heat pump (chilled water) units Part 1: Water Chilling (Heat Pump) Packages for Industrial & Commercial and Similar Application.

IV. Specifications

1. Model Nomenclature

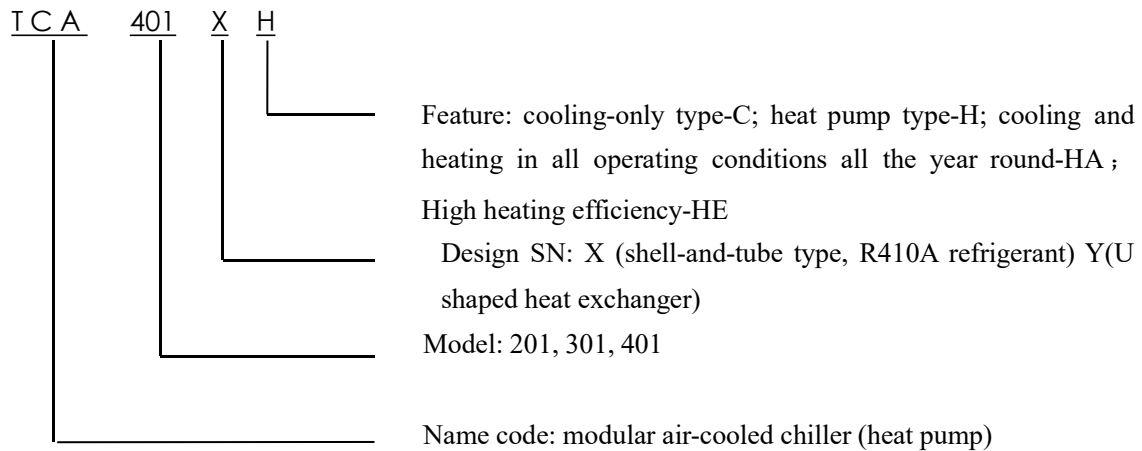

2. Technical Specifications

Note: The performance parameters on the unit nameplate shall prevail if the following performance parameters differ from those on the nameplate.

(1) Performance parameter list of perennial heating and cooling units in all operating conditions and standard units

Model		TCA201XHA	TCA201XH	TCA301XH	TCA401YH	
Nominal cooling capacity	kW	66	66	100	130	
Nominal heating capacity	kW	70	70	110	140	
Nominal Cooling Power Input	kW	21.29	21.29	32.25	39	
Nominal Heating Power Input	kW	21.85	21.85	34.37	42	
Max. Power Input	kW	30.2	30.2	43.6	58.6	
Single unit energy regulation	%	0-50-100				
Power supply	-	380-400V 3N~ 50Hz				
Rated water flow	m ³ /h	11.4	11.4	17.2	22.4	
Water resistance	kPa	45	45	30	55	
Water inlet/outlet pipe diameter	DN	DN65 (flange connection)				
Operating mode	-	Automatic operation controlled by microcomputers				
Compressor type	-	Hermetic scroll compressor				
Compressor quantity	Set	2	2	4	2	
Fan	Type	Low-noise axial fan				
	Air flow	m ³ /h	26000	28000	43000	47000
	Qty	Set	2			
Refrigerant	Type	R410A				
Dimensions	Length	mm	2200	2200	2200	2200
	Width	mm	860	860	1100	1150
	Height	mm	1980	2000	2205	2080
Unit weight	kg	620	580	850	800	

Remarks:

- The nominal cooling capacity and nominal cooling input power are tested at the rated water flow, water outlet temperature of 7°C, and outdoor dry-bulb temperature of 35°C. The nominal heating capacity and nominal heating input power are tested at the rated water flow, water outlet temperature of 45°C, outdoor dry-bulb temperature of 7°C or

outdoor web-bulb temperature of 6°C.

2. About 6% loss caused by system pipelines, water pumps, valves, and dirt after unit installation shall be considered for the cooling (heating) capacity in actual application.
3. Units of model TCA201/301XH are not allowed to run in cooling mode at an ambient temperature lower than 5°C, and units of model TCA201XHA are not allowed to run in cooling mode at an ambient temperature lower than -20°C, units of model TCA401YH are not allowed to run in cooling mode at an ambient temperature lower than -18°C.
4. The specifications are subject to change due to product improvement without a prior notice;
5. The specifications above are based on a single module. Multiple modules can be used in combination. Units of model TCA201/301XH and TCA401YH and TCA201XHA support the combination of a maximum of 16 modules.

(2) Performance parameter list of cooling-only and comfortable units

Model		TCA201XC	TCA401XC	TCA201YCG	TCA401YCG	
Nominal cooling capacity	kW	66	130	66	130	
Nominal heating capacity	kW	/	/	/	/	
Nominal Cooling Power Input	kW	21.29	41.9	21.29	42	
Nominal Heating Power Input	kW	/	/	/	/	
Max. Power Input	kW	57.6	57.6	30	52	
Single unit energy regulation	%	0-100	0-50-100	0-50-100	0-50-100	
Power supply	-	380-400V 3N~ 50Hz		220V 3N~60Hz		
Rated water flow	m ³ /h	11.4	22.4	11.4	22.4	
Water resistance	kPa	45	45	45	50	
Water inlet/outlet pipe diameter	DN	DN65 (flange connection)				
Operating mode	-	Automatic operation controlled by microcomputers				
Compressor type	-	Hermetic scroll compressor				
Compressor quantity	Set	1	2	2	2	
Fan	Type	-	Low-noise axial fan			
	Air flow	m ³ /h	28000	48000	29000	47000
	Qty	Set	2			
Refrigerant	Type	-	R410A			
Dimensions	Length	mm	2200	2200	2000	2250
	Width	mm	860	1100	950	1150
	Height	mm	2130	2205	2070	2080
Unit weight	kg	570	850	540	780	

Remarks:

1. The nominal cooling capacity and nominal cooling input power are tested at the rated water flow, water outlet temperature of 7°C, and outdoor dry-bulb temperature of 35°C.
2. About 6% loss caused by system pipelines, water pumps, valves, and dirt after unit installation shall be considered for the cooling (heating) capacity in actual application.
3. TCA201/401XC are not allowed to run at an ambient temperature lower than 5°C, TCA201/401YCG are not allowed to run at an ambient temperature lower than 5°C.
4. The specifications are subject to change due to product improvement without a prior notice;
5. The specifications above are based on a single module. Multiple modules can be used in combination. Units of model TCA201/401XC support the combination of a maximum of 16 modules.

(3) Non-standard power

Model		TCA301XC/B	TCA401XC/A
Nominal cooling capacity	kW	100	130
Nominal heating capacity	kW	/	/
Nominal Cooling Power Input	kW	32.25	41.9
Nominal Heating Power Input	kW	/	/
Max. Power Input	kW	42	55
Single unit energy regulation	%	0-50-100	
Power supply	-	460V 3N~ 60Hz	380V 3N~ 60Hz
Rated water flow	m ³ /h	17.2	22.4
Water resistance	kPa	60	45
Water inlet/outlet pipe diameter	DN	DN65 (flange connection)	
Operating mode	-	Automatic operation controlled by microcomputers	
Compressor type	-	Hermetic scroll compressor	
Compressor quantity	Set	2	2
Fan	Type	Low-noise axial fan	
	Air flow	36000	48000
	Qty	2	
Refrigerant	Type	R410A	
Dimensions	Length	2200	2200
	Width	1100	1100
	Height	2205	2205

(4) High heating efficiency

Model		TCA201XHE	TCA401YHE
Nominal cooling capacity	kW	70	150
Nominal heating capacity	kW	78	175
Nominal Power Input	kW	21.87	43.8
Max. Power Input	kW	31	73
Single unit energy regulation	%	0-50-100	
Power supply	-	380V 3N~ 50Hz	
Rated water flow	m ³ /h	12	25.8
Water resistance	kPa	50	62
Water inlet/outlet pipe diameter	DN	DN65 (flange connection)	
Operating mode	-	Automatic operation controlled by microcomputers	
Compressor type	-	Hermetic scroll compressor	
Compressor quantity	Set	2	2
Fan	Type	Low-noise axial fan	
	Air flow	30000	43000
	Qty	2	2
Refrigerant	Type	R410A	
Dimensions	Length	2200	2250
	Width	860	1150
	Height	2190	2255
Unit weight	kg	665	940

Remarks:

1. The nominal cooling capacity and nominal cooling input power are tested at the rated water flow, water outlet temperature of 7°C, and outdoor dry-bulb temperature of 35°C. The nominal heating capacity and nominal heating input power are tested at the rated water flow, water outlet temperature of 41°C, and outdoor dry-bulb temperature of -12°C, wet-bulb temperature of -13.5°C.
2. About 6% loss caused by system pipelines, water pumps, valves, and dirt after unit installation shall be considered for the cooling (heating) capacity in actual application.
3. The specifications are subject to change due to product improvement without a prior notice;
4. The specifications above are based on a single module. Multiple modules can be used in combination. Units of model support the combination of a maximum of 16 modules.

3. Structure Diagrams

201XHA

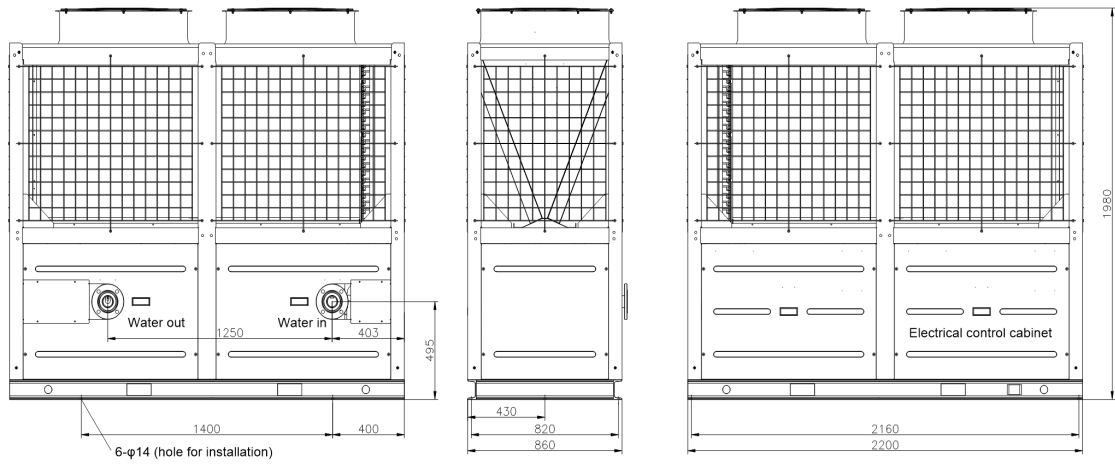

201XH, 201XC

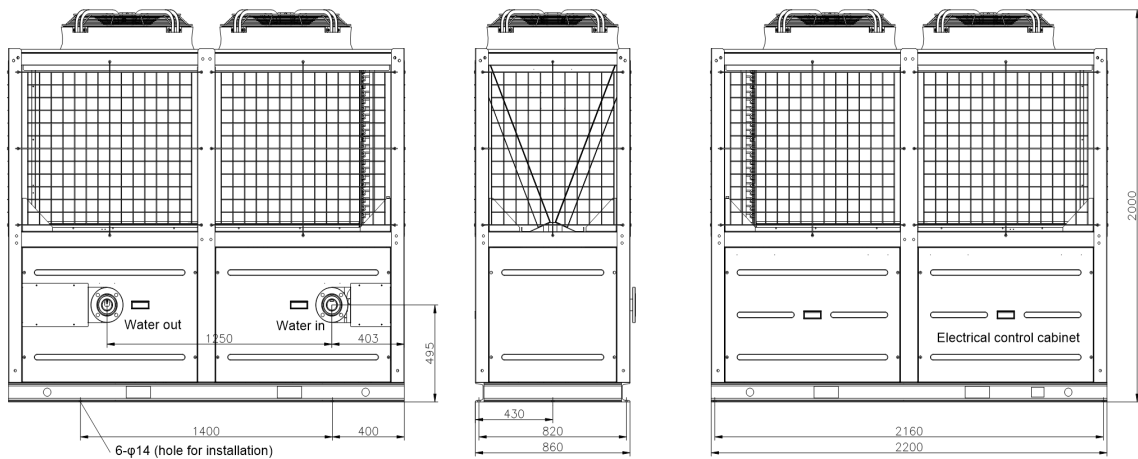

301XH

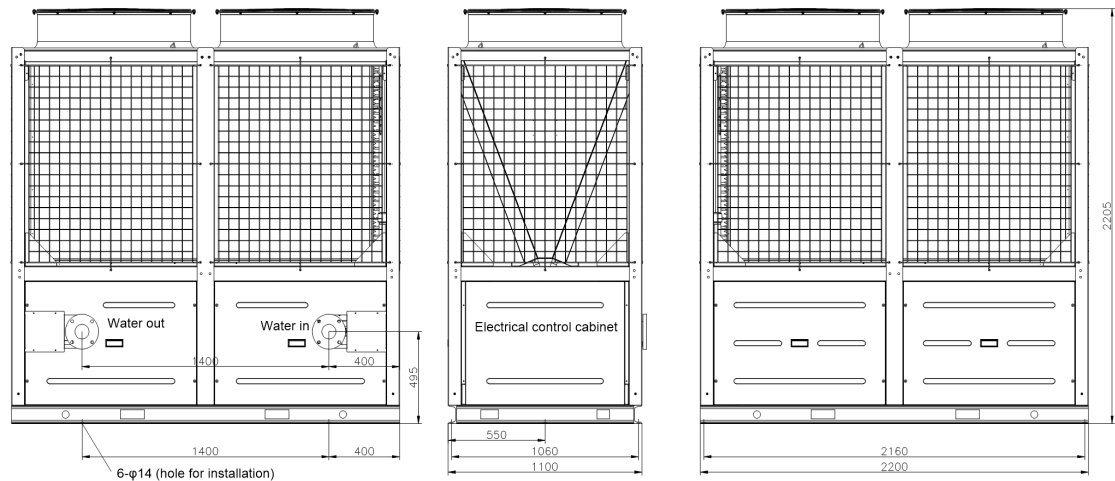

MODULAR AIR-COOLED CHILLER (HEAT PUMP)

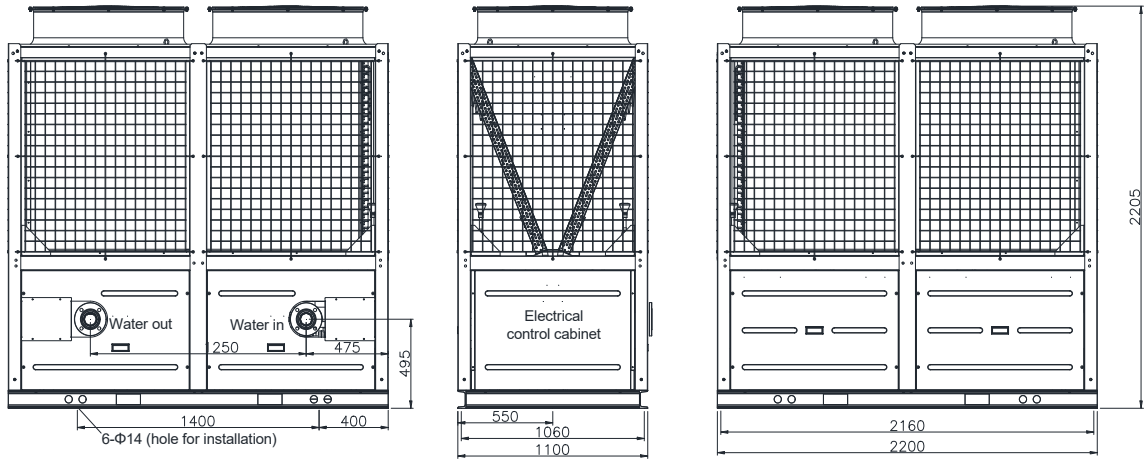

201XHE

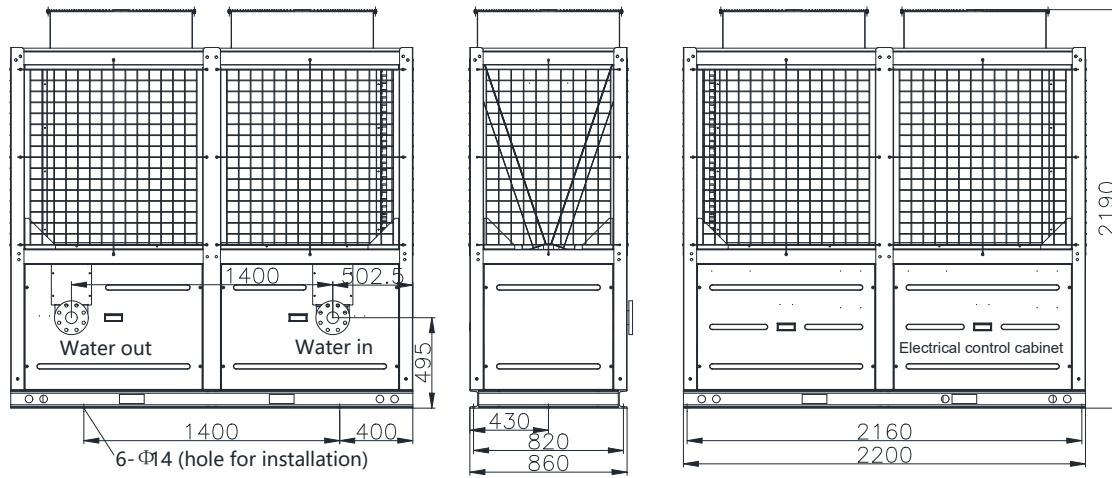

401XHE

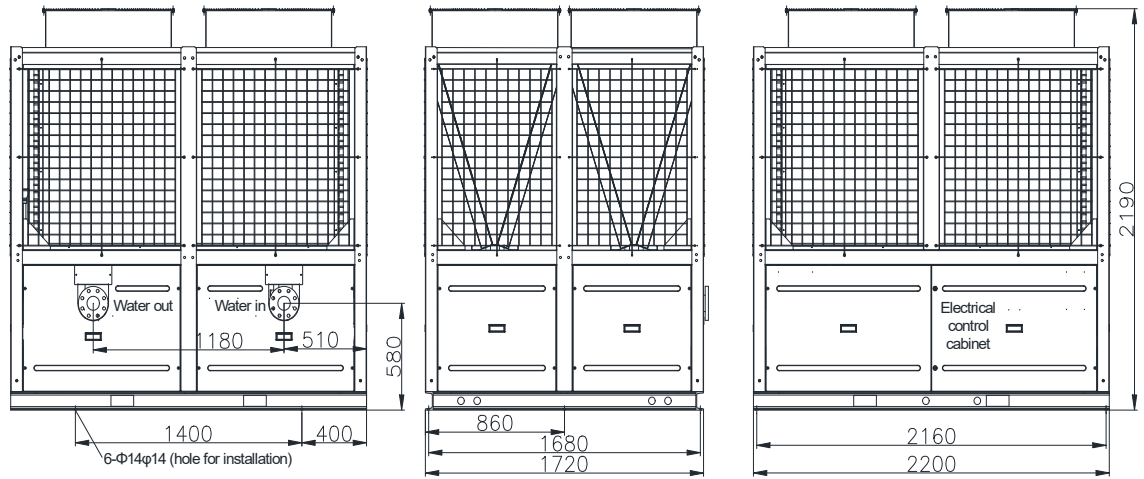

TCA401YHE

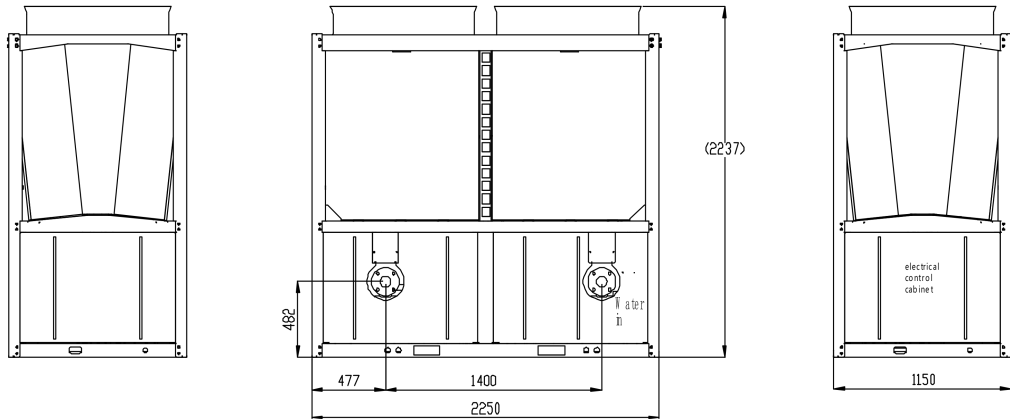

TCA401YH, TCA401YCG

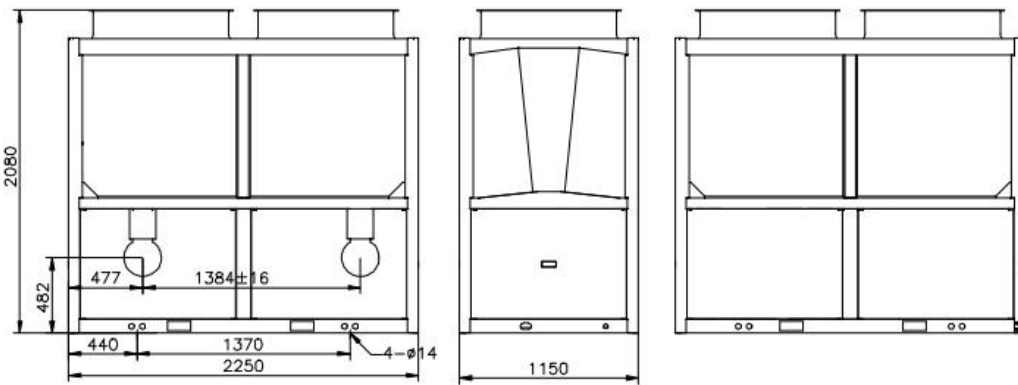

TCA201YCG

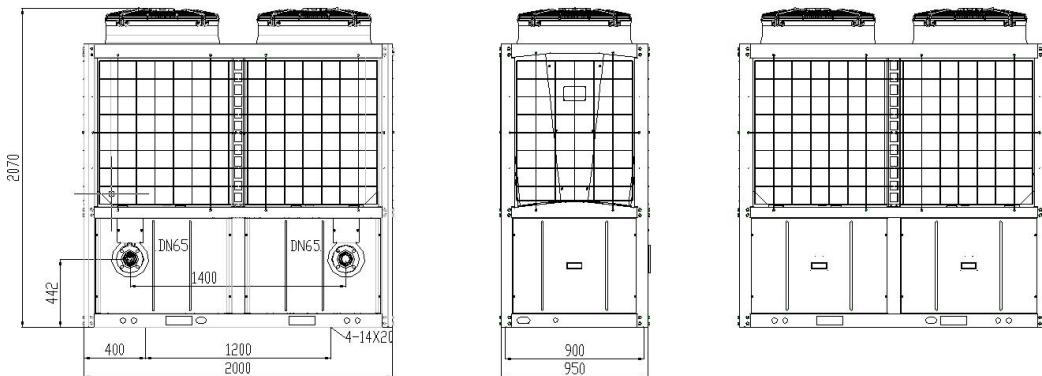

V. Unit Installation

1. Key Points for Installation

Acceptance

After receiving units, a customer shall carefully check whether the unit casings and internal components are in good condition. If a unit is damaged, record it in the delivery note and notify the carrier and local sales office of the damage in written form within three days.

Check whether the power supply for the unit is consistent with the information specified in the nameplates of the unit compressor, fan motor, and 4-way valve, and other components, and check whether information on the unit nameplates is correct. Ensure that the maximum voltage deviation of the power supply cannot exceed $\pm 10\%$.

Handling

Use a forklift or crane with appropriate tonnage to handle units. Use canvas ropes for the handling, wind the canvas ropes around the unit bottom, and tighten the ropes.

For the external dimensions and weight of the unit, see the technical parameter lists.

Installation position

The unit can be installed on the ground or roof with prefabricated unit foundation, dedicated platform, or other places convenient for the unit installation and capable of bearing the unit operation weight. Be sure to pay attention to the following requirements:

- A: Keep the unit more than 1.8 m away from surrounding objects, and ensure proper ventilation conditions for the unit.
- B: When multiple units are placed side by side, keep a distance of at least 3.0 m between two adjacent units to ensure excellent heat transfer effect.
- C: Install the unit close to the main power supply, to prevent unit startup exception caused by excessive voltage drop.
- D: Construct drains around the unit beforehand and take account of the unit drainage in winter.
- E: Install the unit more than 10 m away from residential areas to prevent noise from disturbing residents during unit operation.

Caution

Acid, alkali, salt spray and other corrosive gases will damage the unit casing, pipeline or electrical components. The unit installation position must be far away from the site with corrosive gases.

2. Installation Diagrams

(1) Installation Foundation Diagrams

The unit can be directly placed on a base with drains reserved around. The base can be

precast using cement. The unit can be supported by a bracket made of angle steel, with shockproof rubber pads. It can be also placed on the ground or flat roof. The base surface must be flat and horizontal.

The figure below shows the base for modular combination installation of the TCA301XC/B, TCA401XC/A, TCA201/301/401XH, TCA201/401XC, and TCA201XHA units.

Installation Spacing (mm)		
Model	m	n
TCA201	≥	860
TCA301、TCA401 (Except TCA401XHE)	≥	1100

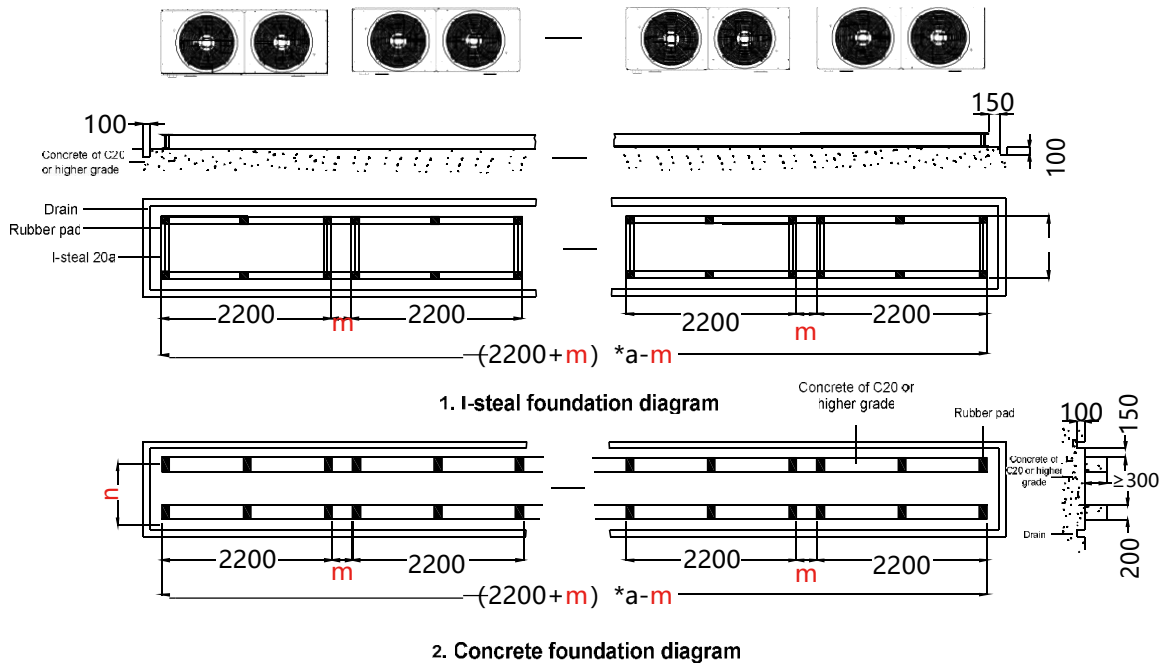

The figure below shows the foundation for modular combination installation of the TCA401XHE units.

Installation Spacing (mm)		
Model	m	n
TCA401XHE	≥ 1000	1720

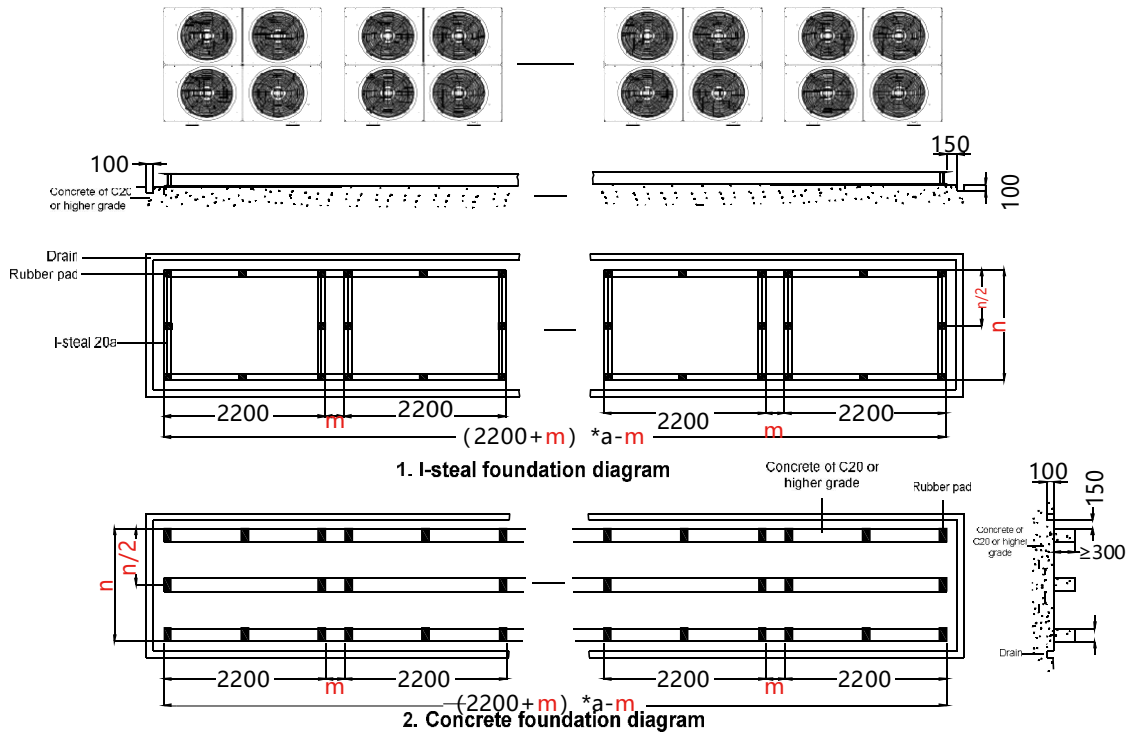

The figure below shows the foundation for modular combination installation of the TCA401YHE, TCA401YH, TCA201YCG, TCA401YCG units.

Installation Spacing (mm)			
Model	L	m	n
TCA401YHE	2250	≥ 500	1150
TCA401YH	2250	≥ 500	1150
TCA201YCG	2250	≥ 500	950
TCA401YCG	2250	≥ 500	1150

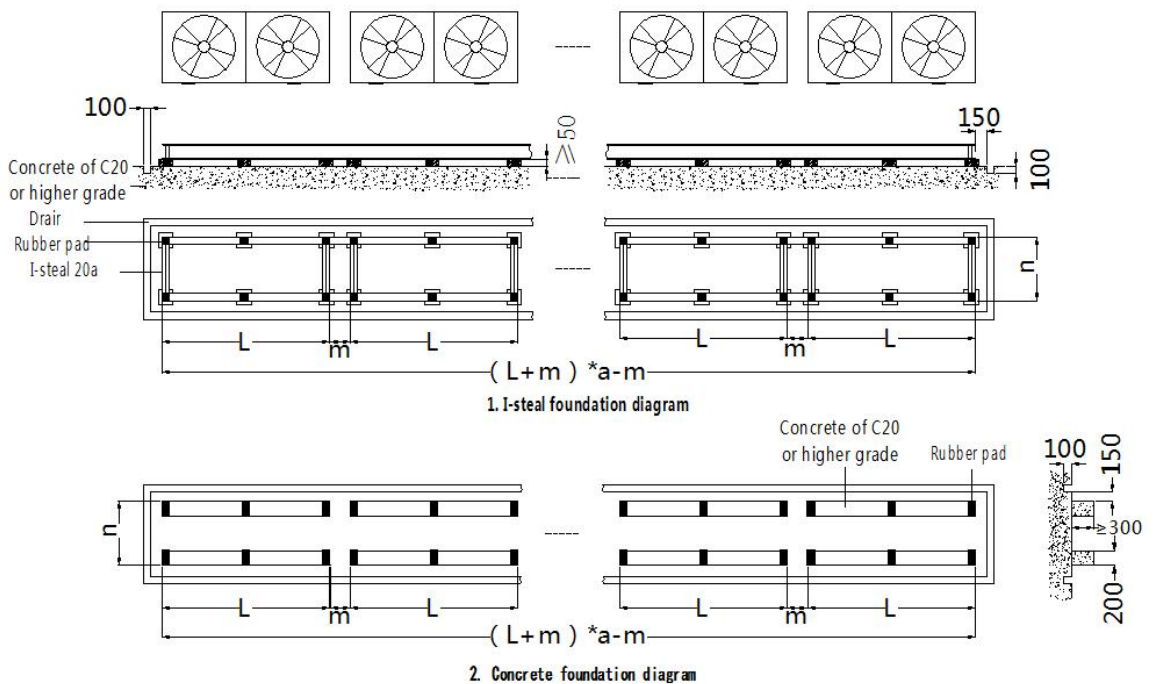

Notes:

- a. a indicates the number of modules of different models. For the values of *m* and *n*, see the table in the installation foundation diagrams.
- b. The foundation is made of reinforced concrete or channel steel frame, and is capable of bearing the weight of no less than 500 kg/m².
- c. Use rubber damping pads or shock absorbers with the thickness not smaller than 20 mm between the unit base and the foundation.
- d. Use M10 bolts to fasten the unit to the foundation.
- e. The foundation surface must be flat and horizontal and drains need to be reserved around the foundation.
- f. The I-beam steel foundation needs to be drained by column frame height; the reinforced concrete structure needs to be done by each unit independently, and the foundation is separated and drained. For snow and frozen areas, it is necessary to improve the foundation and strengthen the drainage capacity. See the anti icing measures at the back.

(2) Installation Space Diagrams

The figure below shows the installation space of the TCA301XC/A, TCA401XC/A, TCA401XH/A, TCA201/301/401XH, TCA201/401XC, and TCA201XHA units.

Installation Spacing (mm)		
Model	m	n
TCA201	≥ 100	860
TCA301/TCA401(Except TCA401XHE)	≥ 500	1100
TCA401YH,TCA401YHE,TCA401YCG	≥ 500	1150
TCA201YCG	≥ 500	950

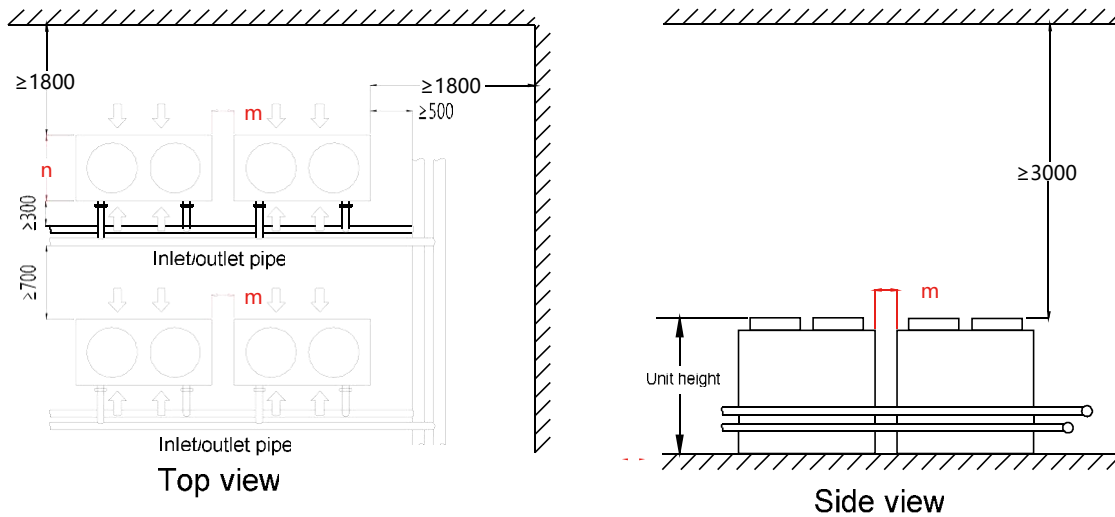

The figure below shows the installation space of the TCA401XHE units.

Installation Spacing (mm)		
Model	m	n
TCA401XHE	≥ 1000	1720

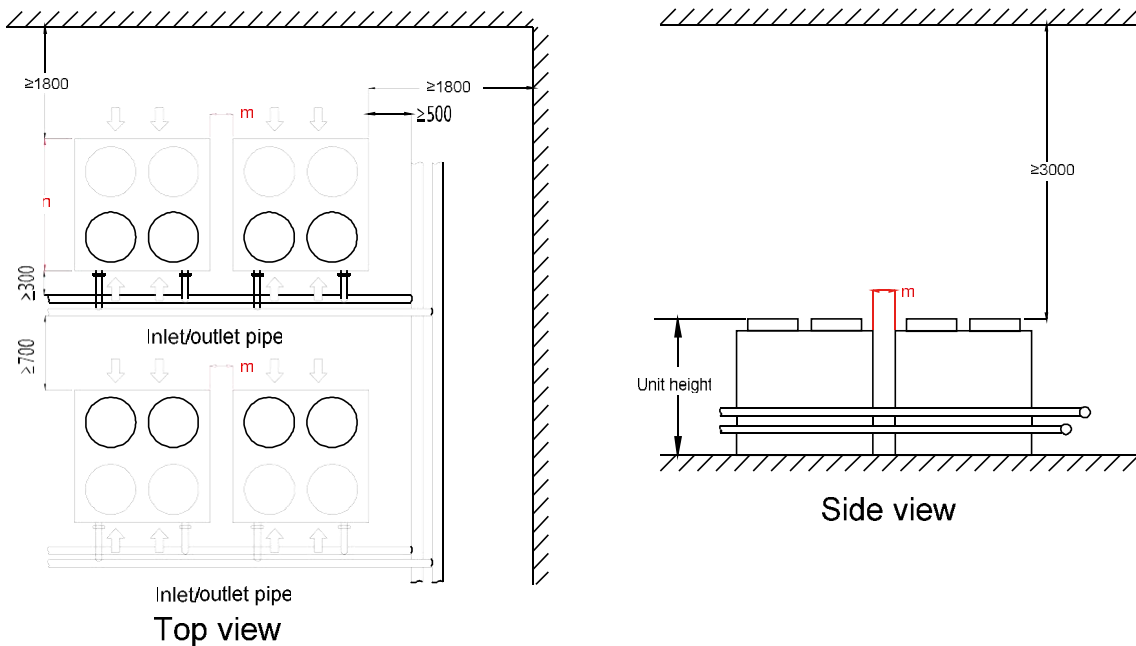

Notes:

- The installation space of the unit must meet relevant dimension requirements for the ease of overhaul and maintenance.
- The diameters of the main water inlet and outlet pipes of the unit must be verified by professionals with a reference to the recommended pipe diameters in the manual.
- Keep a certain distance between the main water inlet and outlet main pipes of the unit and the unit for the ease of installation and maintenance.
- Install sewage valves and drain valves at the lowest positions of the main water inlet and outlet pipes and reserve drains around the unit.

(3) Monsoon Area

In the region of Monsoon, if air side heat exchanger is installed against monsoon, please install wind cap as request in case strong wind may affect air flow of the unit, meanwhile avoid snow accumulation when snowing.

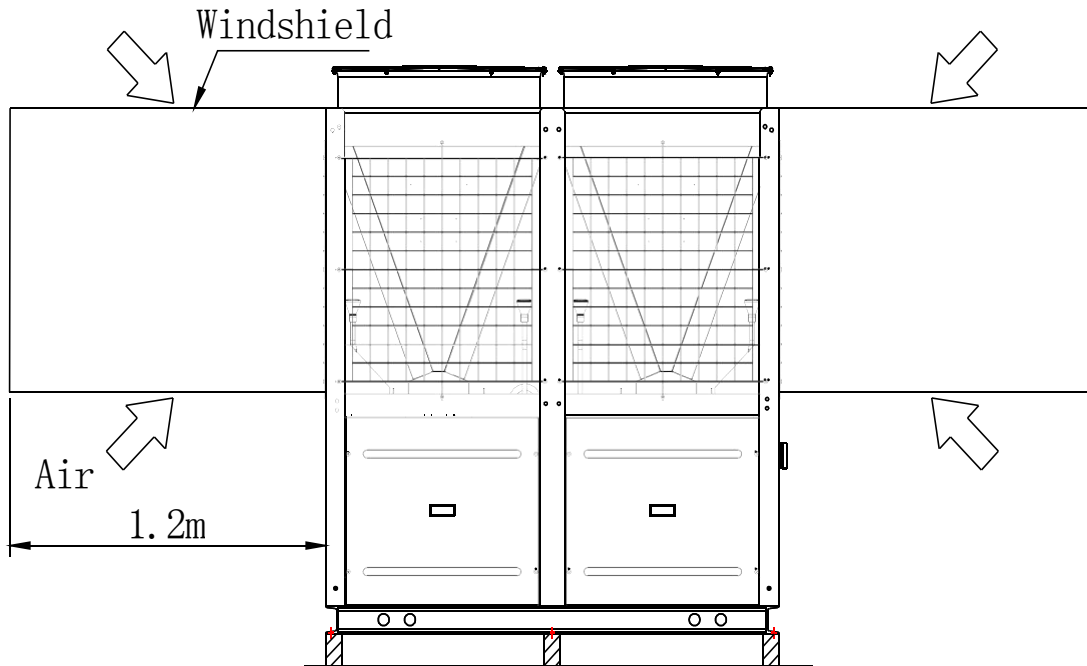

(4) Cold Area and Anti Snow

In the region of frequent snow, please make treatment of anti snow to air side heat exchanger and air outlet. Meanwhile, please raise installation height in the freezing and snow area.

Installation diagram of snow area:

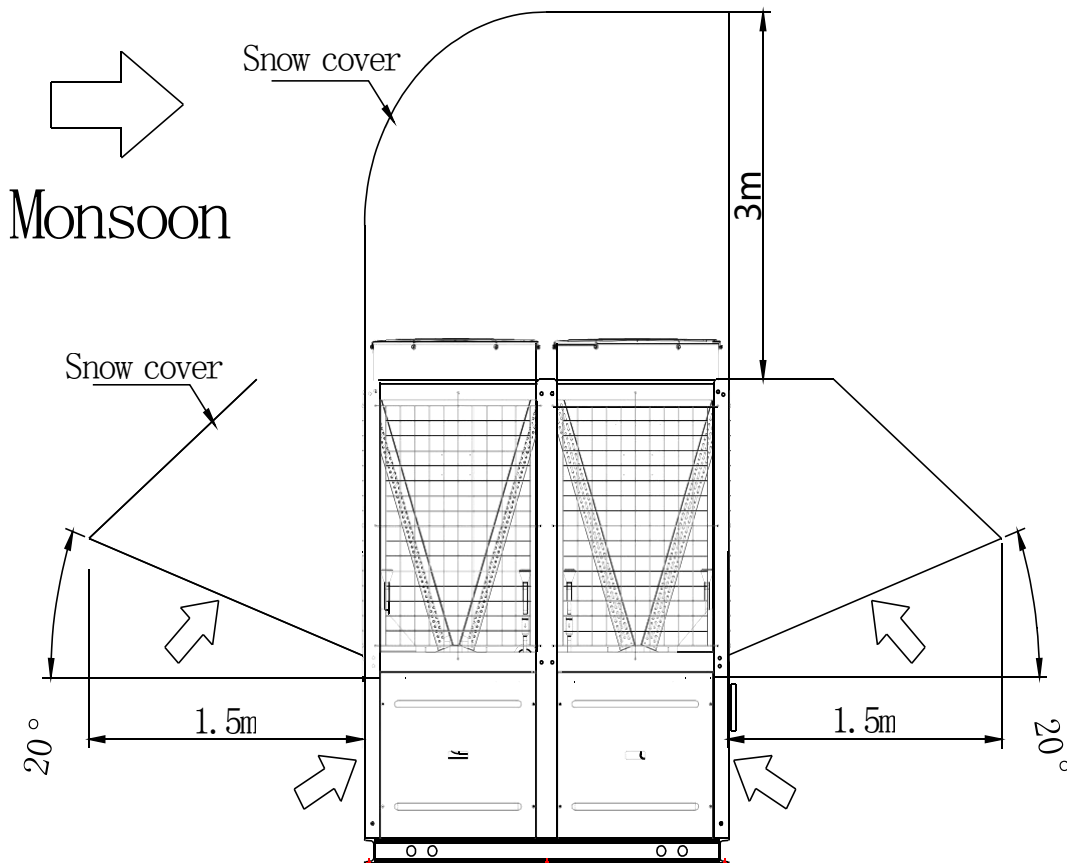

Installation diagram of freezing area:

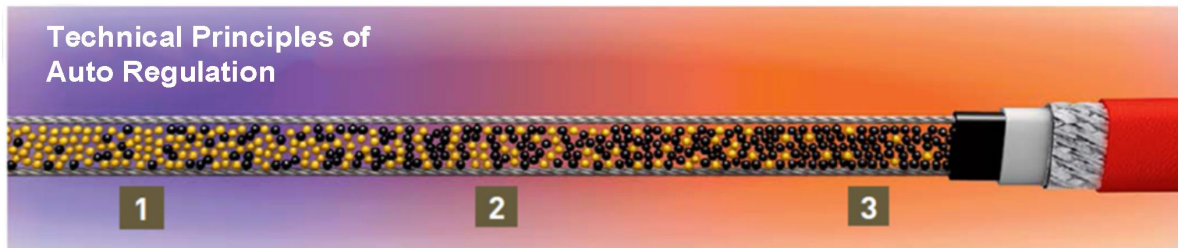
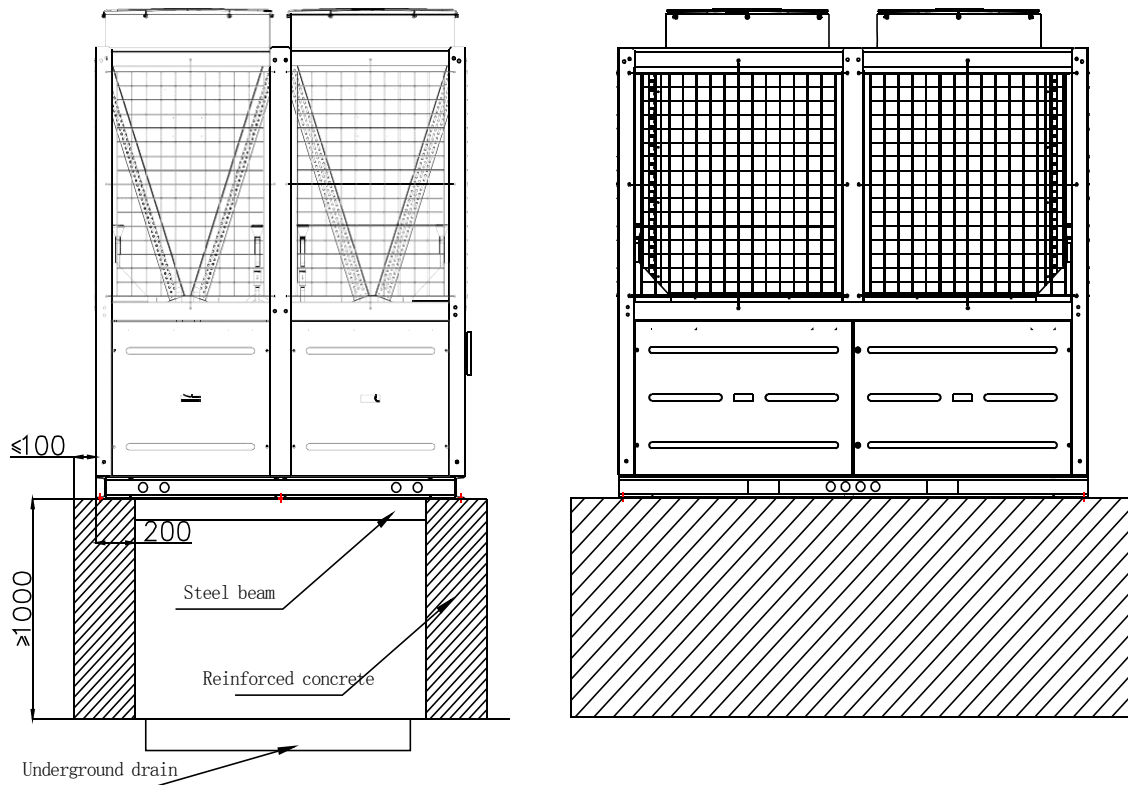

The gold particle represents a formed conductive path

1 Ambient temperature drop = Output power rise

When the ambient temperature drops, the auto regulating heating cable outputs more heat. The polymer core of the cable has micro contraction, generating a great number of conductive paths that are composed of carbon atoms.

2 Ambient temperature rise = Output power drop

When the ambient temperature rises, the auto regulating heating cable reduces the heat output. The polymer core of the cable has micro expansion, reducing the number of conductive paths.

3 Ambient temperature rise = 0 output power

When the ambient temperature rises high, the auto regulating heating cable has output power approximating zero. The polymer core of the cable has the maximum micro expansion, disconnecting almost all conductive paths.

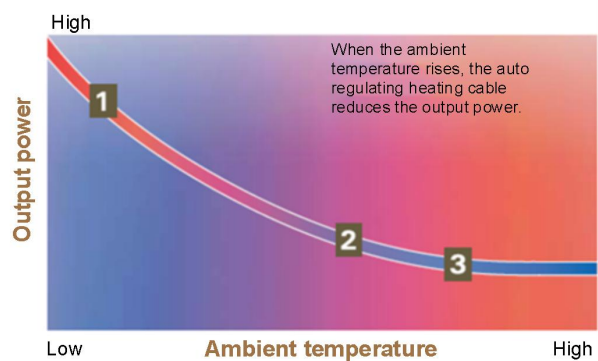

When the ambient temperature rises, the auto regulating heating cable reduces the output power.

3. Unit Installation

Caution

After a unit is delivered from the factory to the installation site, keep the proper package before hoisting. Pay attention to the following points during hoisting:

- A: Handle the unit with care and keep the unit upright.**
- B: Prevent sliding caused by collision with other objects. No person is allowed to stand below or near the unit for the sake of safety. Select the round steel, rope, and crane based on the weight of the unit.**
- C: Use protection pads in places where steel ropes contact the unit, to prevent scratches or unit deformation. In addition, use supports between ropes to prevent the tightened ropes from damaging the unit.**

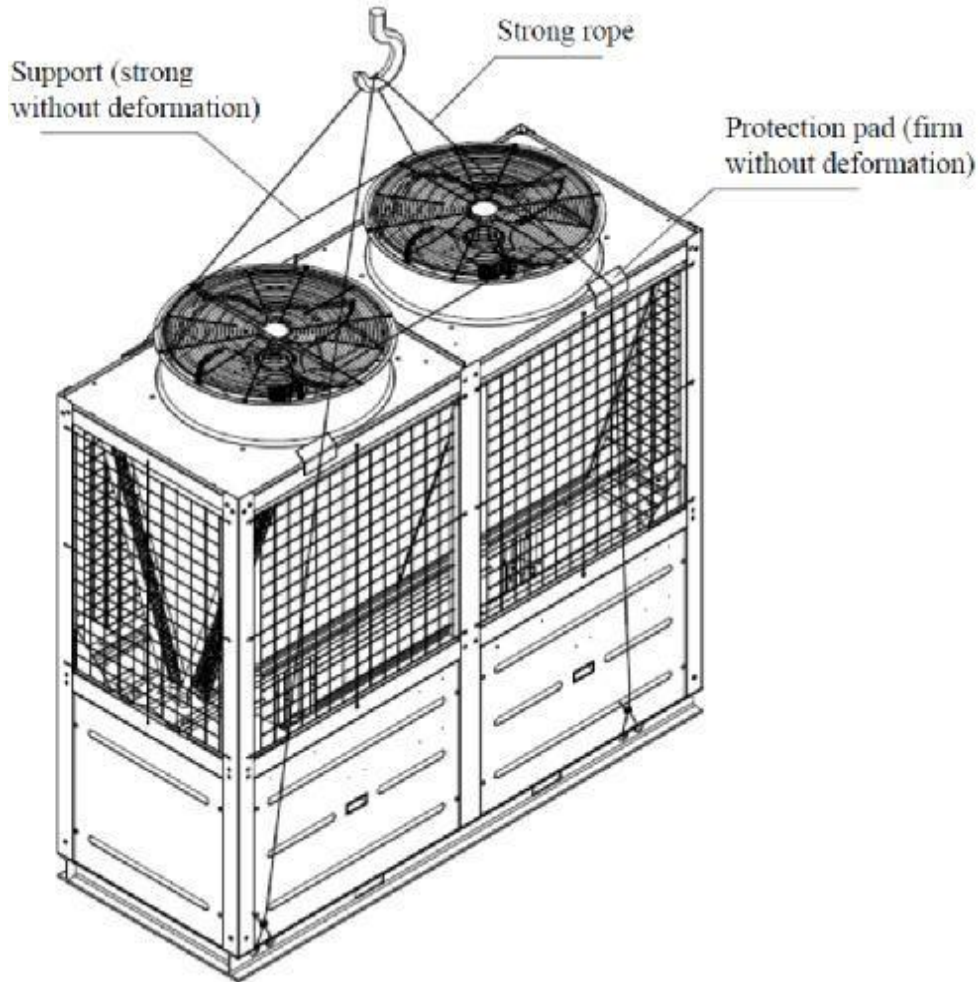

Hoisting diagram for common models

4. Installation of the Water System

Cooling capacity (refrigeration ton)	20 - 40	50 - 60	80 - 160	160 - 240	240 - 500	500 - 800
Water pipe diameter DN (mm)	80	100	125	150	200	250

Refer to the following table for the diameters of the main water inlet and outlet pipes of the unit.

(1) Unit Pipe Schematic Diagram

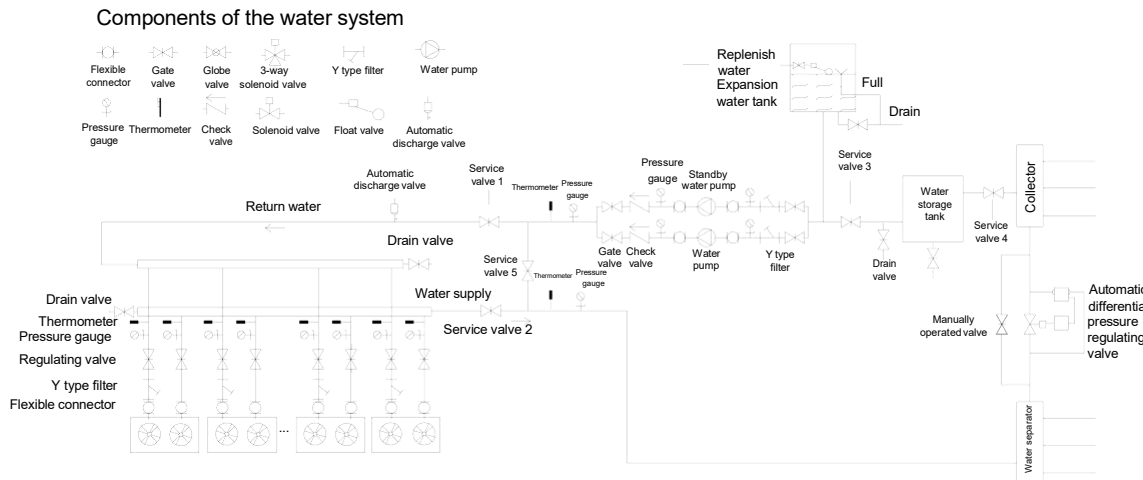

Note:

- a. The figure shows the installation of the water system. The installation is subject to the construction drawings of the design institute.
- b. Water flow switches have been installed inside the unit and they do not need to be installed on site.
- c. The water system of the unit shall ensure that water flow is evenly distributed between units.
- d. The water flow of the unit shall not be smaller than the value specified on the nameplate at any time as long as the unit is running. The water flow needs to be ensured in transition seasons. The condensation temperature is low and the cooling effect is good in transition seasons, and therefore, the water flow of the unit shall be fully ensured, to prevent frequent startup and shutdown of the unit due to water outlet under-temperature. The water flow should be within the range of 90% to 110% of the value specified on the nameplate.
- e. Space must be reserved between modular units to ensure smooth ventilation.

(2) Precautions for Construction of the Water System

- a. Complete piping for the water system as per the method described in this manual, and correctly carry out the construction according to the water heating pipe construction standard.
- b. Determine the diameters of trunk pipes based on pipe sizes, water flow, and cooling capacity of the unit.
- c. It is recommended to connect indoor air-side devices in reversed backwater (direct turn connection) manner, to ensure even distribution of water.
- d. A Y-type water filter must be installed at the water inlet of the plate type unit, to prevent dirt in the water system from clogging the water-side heat exchanger. Pay attention to the flow direction during installation. Check valves must be installed at both ends of the Y-type water filter so that the filter can be dismantled for cleaning. For shell-and-tube units, a Y-type water filter needs to be installed only on the main water inlet pipeline of the unit.
- e. Install a thermometer and a pressure gauge on the water inlet and outlet pipes of the unit so as to check the operation status of the unit conveniently.

- f. Install a water flow regulating valve on each water outlet branch pipe of the unit, to regulate the flow of water entering each unit to be consistent.
- g. Install drain valves on the water inlet and outlet pipes of the unit. With the drain valves, water inside the unit can be drained away when the unit is not used for long in winter, thereby preventing water from freezing in the water-side heat exchanger and water pump and damaging the unit.
- h. Install water pipes horizontally or vertically. No leakage is allowed on pipelines and connection parts, and the thermal insulation effect should be good. Install an air discharge valve and a filling expansion water tank (open-type water tank) at the highest position of pipes, and install a pressure relief valve on the water outlet side of the water pump.
- i. Keep a certain slope when installing horizontal pipes so that air can be discharged smoothly.
- j. Avoid air in the system pipeline in the piping design and construction. Install automatic air discharge valves at the highest positions of water supply and return pipes, so as to discharge air in the system.
- k. Water pumps must be selected based on the flow and the required head. The water pump is generally installed on the main water inlet pipe of the unit. When the outlet pressure of the water pump is greater than 0.8 MPa, it is recommended to install the water pump on the main water outlet pipe to prevent high pressure from damaging the unit.
- l. The automatic differential pressure regulator can make the entire system work more stably.
- m. Manifold is used to distribute water flow of branch pipes more properly.
- n. Water supply valves and check valves must be installed indoor, lest water supply pipes and valves will crack due to water freezing in winter.
- o. The indoor unit and pipeline system should be designed and installed by professionals based on the actual pipeline direction of buildings in accordance with relevant technical specifications. Avoid "U-shaped" bending and "n-shaped" bending. Otherwise, poor air discharge may be incurred and water resistance may be increased, causing air clogging.
- p. If an auxiliary heat source such as an auxiliary electric heater is used, install it on the main water outlet pipe of the unit.
- q. To ensure water resistance balance, install the water system of the unit in direct return manner.
- r. After the water system is installed, test the water pressure for leakage and drain sewage in accordance with the Heating, Ventilation, and Air Conditioning (HVAC) installation specifications. Clean water filters to ensure cleanness inside pipes of the system and no rust dirt inside. Otherwise, the pipeline, water-side heat exchanger, and water pumps may be clogged, causing the unit damage.

Warning

Water filters need to be cleaned periodically, lest water-side heat exchanger

may be clogged, causing severe damage of the unit.

Caution

Install an energy storage water tank on the main return water pipe of the unit and calculate the water volume as per the method described in this manual. The energy storage water tank is used to adjust the capacity of the unit, reduce frequent compressor startup and shutdown due to load changes of the air-conditioning system, improve the operation efficiency of the system, and prolong the service life of the unit.

After the water system is installed, the main water outlet temperature sensing probe of the unit must be installed on the main water outlet pipe of the unit, so as to accurately sense changes in the water temperature of the unit and control the normal operation of the unit. In order to make the water temperature sensing probe accurately detect the water outlet temperature, it is required to open a blind hole on the main water outlet pipe, and then insert the temperature sensing probe into the blind hole. Otherwise, the unit may malfunction.

(3) Water Quality Requirements

To prevent water from corroding and clogging the water system of the unit, ensure that water filled into the water system is clean, with the pH value ranging from 7.5 to 9.0. The existence of oil, salt, acidic gas or liquid in the water system will reduce the system performance and even damage the unit, resulting in the unit operation failure. The content of calcium and magnesium ions in the water of the water system should be lower than 150 mg/L, and the content of chlorine ions should be lower than 300 mg/L (recommended). The water quality should be inspected before water is injected into the heat exchanger of the unit. If the water quality does not meet the requirements of air-conditioning water, water treatment is required. For the water treatment, see the *Code for Design of Industrial Recirculating Cooling Water Treatment* or other relevant standards.

(4) Pressure Testing and Flushing

- a. The strength test pressure of the whole metal pipe network water system should be 1.5 times the design work pressure, but should not be smaller than 0.6 MPa. After the pressure is maintained for 10 minutes, the pressure drop is not greater than 0.02 MPa and no leakage, deformation, and other abnormal phenomenon occur. The pressure for the air tightness test should be the design work pressure, and no leakage occurs after the pressure is kept for 60 minutes. (Note that the pressure at the lowest point shall not exceed the bearing pressure of its components).
- b. The water pressure test shall not be carried out when the atmospheric temperature is below 5°C. The pressure gauge for the testing should be qualified, the accuracy is not lower than Level 1.5, and the full-scale value is 1.5-2.0 times of the maximum measured

pressure.

- c. Add water from a low position and discharge air from a high position during pressure testing. Add water slowly and evenly, stop the pump operation when the pressure reaches the required pressure, and check the system. Do not carry out the repair work when pressure is not relieved.
- d. After the water system passes the pressure testing, flush the water pipeline repeatedly (ensure that the water does not pass through the chiller and air-side devices of the air-conditioning system) till no silt, iron rust, and other impurities are drained from the water system and water is not turbid.
- e. After the pressure testing and flushing, clean the water filter installed on the main water inlet pipe and filters at the water pump inlets, disassemble the water-side service panel of the chiller, and clean water filters provided with the water inlet branch pipes of the unit. Install the service panel and check for leakage after cleaning.

(5) Installation of the Energy Storage Water Tank

In order to ensure the control accuracy and stability of water outlet temperature as well as safe operation of the unit, the system must be equipped with a water tank with the minimum volume. The water tank can prevent frequent load increase/decrease of internal compressors in the unit and prolong the service life of the unit. The controller limits frequent unit startup and shutdown to prevent compressor damage. A compressor cannot be started for more than six times one hour.

The minimum water volume of the system can be approximated to 10 L/kW (that is, the minimum water volume of the system is 1 m³ when the cooling capacity of the unit is 100 kW, and the water volume of the system should be at least 3 m³ for medical purification and other technological air conditioning sites). The size of the energy storage water tank is determined based on the difference between the calculated minimum water volume and the actual water volume.

In order to meet the water volume requirements above, one energy storage water tank needs to be added for general sites, and baffle plates need to be installed in the water tank, to prevent short water flow. The figure below shows the general installation of baffle plates.

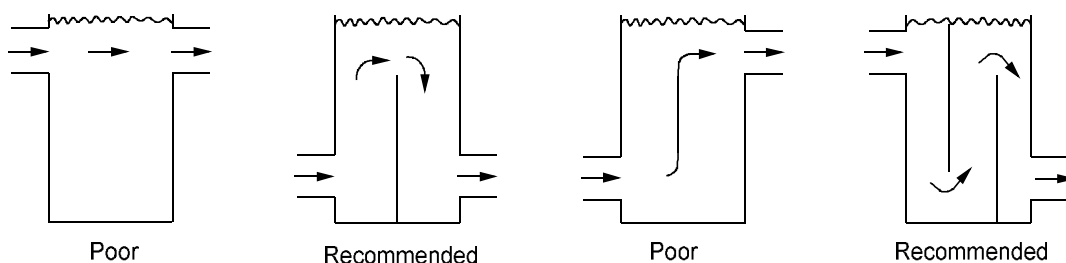

Caution

For occasions with a small water capacity, an energy storage water tank must be installed to ensure stable operation of the unit. Otherwise, the unit may be damaged due to water temperature too high or too low.

(6) Installation of Water Flow Switches

A water flow switch is 1 inch in size with external thread. Water flow switches must be upright and installed in straight pipe section. The length of the straight pipe section before and after a water flow switch must be greater than 5 times the pipe diameter. (For detailed installation method, see the manual delivered with the water flow switch.) The water flow switch of the air-cooled chiller (heat pump) must be installed on the water outlet pipeline of each unit, to ensure sufficient water circulation during the normal operation of the unit, thereby preventing the damage of the water-side heat exchanger due to insufficient water flow or no water during unit operation.

As shown in the figure on the right side, a water flow switch is composed of a water flow switch controller 1, a diaphragm 4, a water flow switch connector 2, and a short tube 3. When water passes through the water flow switch, the water flow strikes the diaphragm, which drives the water flow switch to close, thereby making the circuit close. When there is no water flow or the water flow is very low, the circuit will be disconnected to protect the unit.

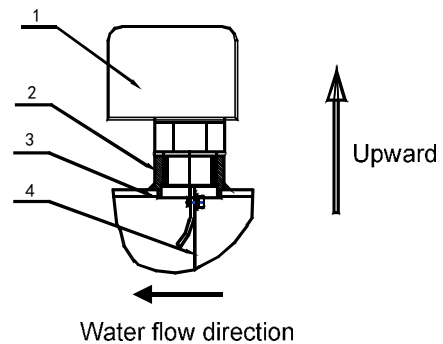

The figure below shows the installation method of the water flow switch and flow direction plates.

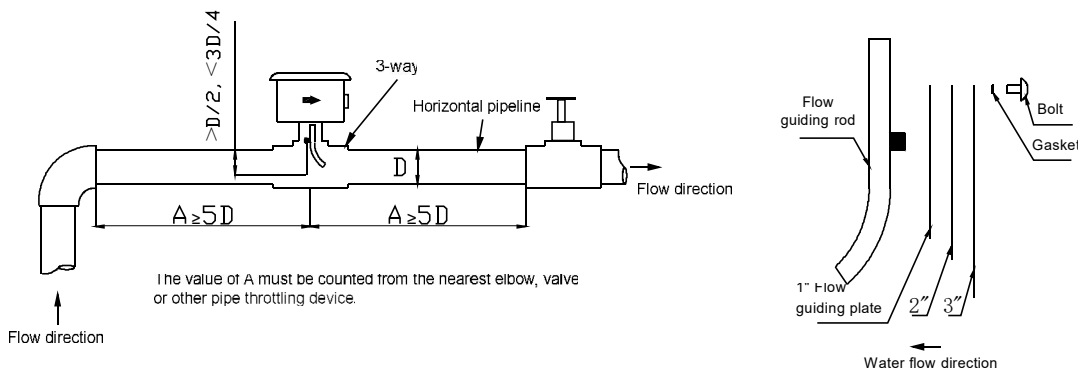

(7) Installation of Air Discharge Valves

Automatic air discharge valves are used to discharge air out of the water system so that the unit works properly. An air discharge valve is installed at the highest position of the system and air discharge valves also need to be installed at high positions of some sections. Air discharge valves aims at discharging air in the system if any.

(8) Installation of the Expansion Water Tank

The expansion water tank aims at adapting the unit to the change of the water volume caused by temperature changes, stabilizing the system pressure, and supplementing water into the system. The expansion water tank is generally installed on the low-pressure pipe (suction side of the water pump) at a height about 3 m higher than the highest position of the water pipeline, to ensure positive pressure of the pump suction inlet and make the unit work properly. The expansion water tank should be insulated against freezing caused by low

ambient temperature in winter, lest it fails to function properly.

The formula for calculating the capacity of the expansion water tank is as follows:

Volume of the expansion water tank: $V = (0.03\sim 0.034) V_c$

V_c indicates the water volume of the system.

(9) Installation of Water Pipelines

Water inlet and outlet collection pipes of the unit:

For the distance between water inlet and outlet collection pipes and the unit as well as the opening size, see the unit layout. Pierce openings at the water inlet and outlet of each module, weld the DN50, DN65, or DN80 water pipes, reserve threaded or flanged interfaces between the water pipes and the unit connection end so that the unit and water pipes are connected in soft connection way. After all pipelines are installed, perform the pressure test and then conduct thermal insulation.

⚠ Caution

A manual gate valve for adjusting the water flow needs to be installed on the water inlet pipe of each module to ensure even water flow distribution during water pipe installation. A drainage hole needs to be installed at the lower part of the water outlet pipe of each module to facilitate water drainage in winter.

Other pipes:

The pipeline installation directly affects the use effect of air-conditioning units. Only qualified installation team is allowed to install pipelines and the installation must comply with industrial standards. The following are some suggestions on pipeline installation:

- a. Water pipelines should be installed based on the hoisting height of air-side devices as well as the height of beam bottom. The installation height determines the pipeline elevation and arrangement. Pipelines can be arranged in parallel or in staggered manner. Staggered arrangement is allowed if the condition permits.
- b. Pipes are generally fastened using supports or hangers. For the form and fastening method of supports and hangers, see the national installation standard atlas. Pipes should be isolated from supports and hangers via wood or other insulation materials based on the on-site conditions, to prevent the occurrence of cold bridge. The table below lists the reference spacing for supports and hangers.

Diameter	< DN25	DN25~DN32	DN40~DN50	DN70~DN80
Spacing m	2.0	2.5	3.0	4.0

- c. Maintain the slope of 1/1000 to 3/1000 regardless of the pipeline arrangement. The sloped pipe installation is conducive to the air discharge via the end of pipelines. The spacing between two pipes should be basically the same and the insulation distance should be reserved, to ensure pipes are horizontally flat and vertically upright. Prevent "U-shaped" bending and "n-shaped" bending. Otherwise, clogging may occur in some areas, resulting in poor air discharge and affecting circulating operation of the water system.

- d. Maintain the slope of 0.5% to 1% in the arrangement of condensate drain pipes. Do not elevate the condensate drain pipes regardless of the hoisting elevation of air-side devices and whether pipelines are wound around the beam. Observe the nearby drainage principle, determine the water drainage point, shorten the pipeline as much as possible, reduce the pipeline decline caused by slope, and raise the ceiling height. Strict thermal insulation is required for condensate pipes.
- e. Air discharge valves on pipelines need to be set based on on-site environment. They are generally set at the end of horizontal pipeline (long pipeline), upper position of stand pipes, and elevated position of some areas, to ensure smooth air discharge of the pipeline system.
- f. It is recommended to set a bypass valve for each layer of the multi-layer air-conditioning pipeline, to regulate the water flow. A drainage valve needs to be set at the lowest point of the pipeline to facilitate system overhaul and water drainage when the unit is not used in winter, thereby preventing water pipe damage caused by frosting.
- g. An open expansion water tank is recommended. The water tank should be installed about 3 m higher than the highest point of the system, and the interface of the water tank needs to be connected to the return water pipe close to the water pump (an air discharge valve is also required for the expansion water tank).

(10) Pipe Diameter

⚠ Caution

The pipe diameter affects the system operation resistance at the same flow rate. Choose pipes with a larger diameter when the condition permits, to reduce the system operation resistance and pump head.

The following table lists the recommended ideal diameter design values for reference.

Ideal flow rate of water in pipes (m/s)

Position	Water Pump Outlet	Water Pump Inlet	Main Pipe	Stand Pipe	Branch Pipe
Flow rate	2.4~3.6	1.2~2.1	1.2~4.5	0.9~3.0	1.5~2.1

Maximum flow rate of water in pipes (m/s)

Annual Running Hours	1500	2000	3000	4000	5000
Flow rate	4.6	4.3	4.0	3.7	3.0

Water flow and resistance loss per unit length

Pipe diameter DN	15	20	25	32	40	50	70	80	100	125

MODULAR AIR-COOLED CHILLER (HEAT PUMP)

Flow L/s	0 ~ 0.14	0.12 ~ 0.32	0.22 ~ 0.60	0.46 ~ 1.2	0.7 ~ 1.8	1.4 ~ 3.6	2.2 ~ 6	4 ~ 11	8 ~ 22	15 ~ 18
Loss kPa/ 100 m	0 ~ 60	10 ~ 60	10 ~ 60	10 ~ 60	10 ~ 60	10 ~ 60	10 ~ 60	10 ~ 60	10 ~ 60	10 ~ 60

The table below lists the pipe diameter and required number of air-side devices (Fan Coil Units (FCUs)). The data is based on the FCU of TCR300-TCR600. Use the lower limit when the size of the FCU is large, and use the upper limit when the size of the FCU is small. For other air-side devices, determine the water pipe diameter based on the actual water flow.

A bypass valve must be installed when a 2-way valve is installed for FCUs, and the bypass valve needs to be interlocked with the 2-way valve. The purpose is to ensure that the bypass valve is open when the 2-way valve is closed, so as to prevent uneven water resistance and water flow.

Pipe Diameter DN	15	20	25	32	40	50	70	80
Number of FCUs	1	1~2	3~5	6~8	9~13	14~20	21~28	29~38

Caution

When 2-way valves are installed for air-side devices but no interlock bypass valve is installed, the number of installed 2-way valves cannot exceed 50% of the total number of air-side devices. The purpose is to prevent an excessive number of closed 2-way valves under partial load operating conditions. Otherwise, the water resistance is too large, the pump is overloaded and damaged, and the unit cannot work properly.

(11) Selection of Other Components of the Water System

A. Gate valve:

Determine the valve based on the water pipe diameter. The diameter of the valve connection pipe is generally the same as that of the water pipe.

B. Water filter

A water filter is used to filter out impurities in the water system and prevent damage of the water-side heat exchanger. A water filter with denser meshes delivers a better filtering effect. 16-20 meshes are recommended.

C. Check valve:

A check valve is used to prevent water backflow from damaging water pumps. The valve caliber is the same as the diameter of the inlet and outlet of water pumps.

D. Bypass valve for air-side devices:

A bypass valve for air-side devices is used to interlock with indoor FCU 2-way valves.

MODULAR AIR-COOLED CHILLER (HEAT PUMP)

2-way valves are used to adjust the water flow of the indoor FCU, and excessive chilled water flows out through the bypass valve, to prevent the evaporator damage when the total water flow is reduced because the 2-way valve is turned down.

E. Differential pressure bypass valve:

If the number of 2-way valves used for air-side devices exceeds 50% of the number of air-side devices and interlock bypass valves are not used, automatic differential pressure bypass control valves need to be installed on the main water supply and return pipes, and bypass water should first flow through the energy storage water tank and then to the

unit. In this way, low-temperature water will not enter the unit and damage the evaporator.

5. Electrical Installation

(1) Power Supply and Electric Parameters of the Unit

The minimum starting voltage of the unit must be kept above 90% of the rated voltage, the voltage must be within $\pm 10\%$ of the rated voltage range during operation, and the voltage difference between the phases should be within the range of $\pm 2\%$.



An adverse impact will be caused to the unit when the voltage is too high or too low. If the voltage is unstable, excessive current will be generated at the moment when the unit starts for operation. Consequently, the unit cannot start.



The distance (i.e., the voltage drop) between the chiller installation position and the power distribution cabinet and the current size should be considered for the conducting wire diameter. Then, decide the power distribution line path and the main switch capacity to ensure normal operation of the unit.

Caution

The main controller must adopt the same power supply system together with the unit.

It is recommended to determine the diameter of the power input wire of the unit as per the table below. That the appliance shall be installed in accordance with national wiring regulations.

Standard power:

Model	Maximum operating current (A)	Minimum cross-sectional area of power wire (mm ²)			Communication connecting wire (RVVP)	Copper bar size (A x B)
		Phase line	Neutral line	GND		
TCA201	50	16	10	16	The wire for connecting the chiller and the remote controller is a 4-core communication wire and the standard length is 30 m.	The cross-sectional area of the copper bar (A x B) shall not be smaller than the square of the main power wire.
TCA201YCG	90	35	16	16		
TCA301	80	35	16	16		
TCA401	100	50	25	25		
TCA401YHE	130	50	25	25		
TCA401YCG	170	70	35	35		

Non-standard power:

Model	Maximum operating current (A)	Minimum cross-sectional area of power wire (mm ²)			Communication connecting wire (RVVP)	Copper bar size (A x B)
		Phase line	Neutral line	GND		
TCA301XC/B	70	25	16	16	The wire for connecting the chiller	The cross-sectional area of the copper bar (A x B)
TCA401XC/A	100	50	25	25	and the remote controller is a 4-core communication wire and the	shall not be smaller than the square of the main power wire.

Caution:

- a. The recommended specification of the power wire is the copper core cable used by the 70°C multi-core PVC insulated cable passing through sleeves and laid through the insulating wall at the ambient temperature of 30°C in the air and 20°C in the ground (see the IEC_60364-5-523 *Wire and Cable Carrier Flow Standard*). If the actual installation conditions on site have changed, select a proper model based on the layout conditions by referring to the conducting wire specifications provided by the wire manufacturer.
- b. The selection of power wires is closely related to the local climate, soil characteristics, cable length and layout mode. Such unit engineering projects are often designed by design institutes and the selection of power wires is subject to the design of the design institutes.
- c. Shielded twisted pairs are recommended for communication wires to prevent interference. It is forbidden to lay out them with power wires together.

(2) Electrical Wiring for the Unit

The figure below uses three units as an example to illustrate the on-site installation and power distribution. Other units can use the similar method.

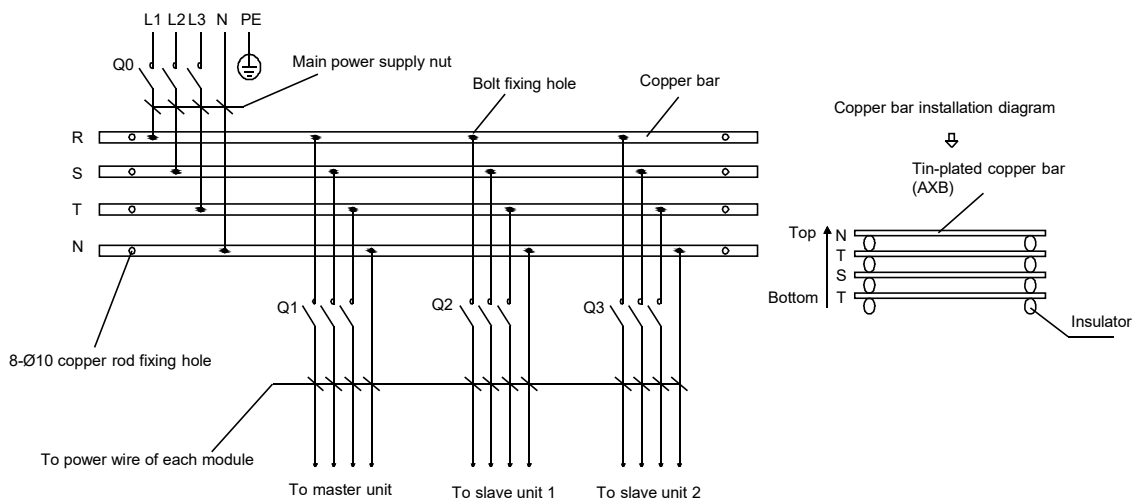

Caution:

- a. The standard unit power is 380 V 3N~ 50 Hz (except non-standard power). TCA201/401YCG power is 220 V 3N~ 60 Hz
- b. Q0 and Q1/Q2/Q3 are air switches and type D air switches are recommended.
- c. Select either Q0 or (Q1/Q2/Q3). (Q1/Q2/Q3) is conducive to the maintenance of single modules.
- d. Consider water pumps and other loads during installation, and select air switches, power wires, and copper bars based on actual situation.
- e. Copper bars are installed vertically. See the copper bar installation diagram.
- f. Copper bars are not required for less than two modules.
- g. The electric wiring diagram is recommended by the manufacturer. Components shown in

the figure are provided for site and are not provided at delivery.

Warning

To ensure personal safety, connect ground wires for the unit in accordance with the electrical regulations.

The unit uses scroll cooling compressors. It is forbidden to run the compressors in reverse direction. Check whether the power supply and electrical components of the unit work properly.

(3) Electrical Wiring Diagram of the Unit

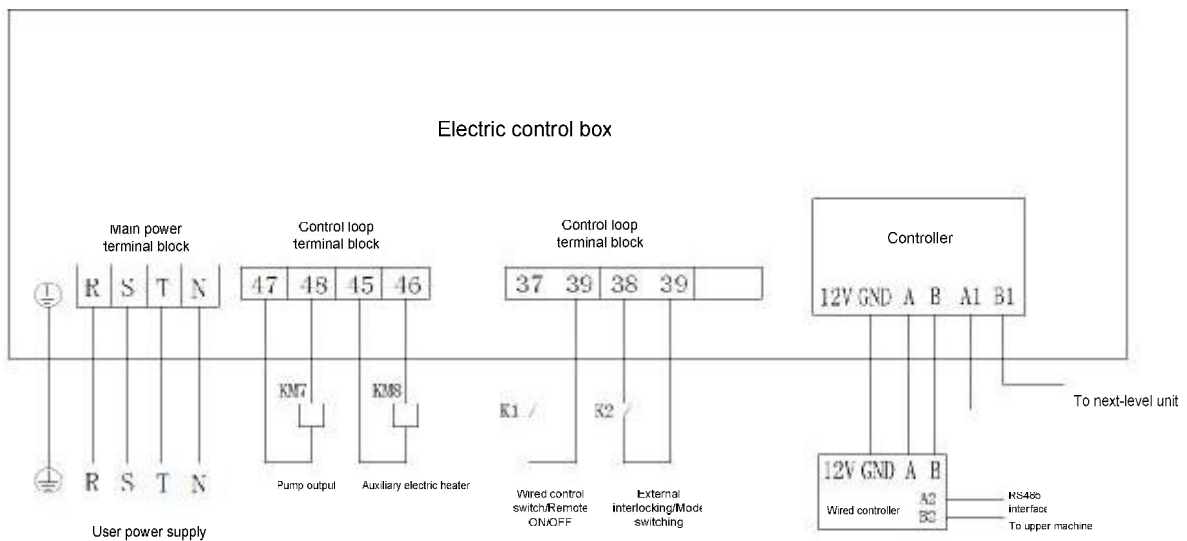

Notes

1. The figure above shows the wiring at the customer site
2. Connect wires for a master unit as per the wiring diagram above
3. The mode switching and remote ON/OFF functions are disabled for standard units. If they are required, turn the DIP switch to remote control. 'K' is used for starting or shutting down the unit. Unit OFF if it is opened and unit ON if it is closed, and K2 is used for mode switching (cooling mode if it is opened and heating mode if it is closed). The wired controller cannot be used to start or shut down the unit.
4. In local control mode, centralized control of buildings can be implemented via the RS-485 interface on the wired controller. The wired controller does not need to be connected in remote control.
5. The figure above is a schematic diagram. The circuit diagram pasted to the unit shall prevail.

(4) Unit Interconnection Schematic Diagram

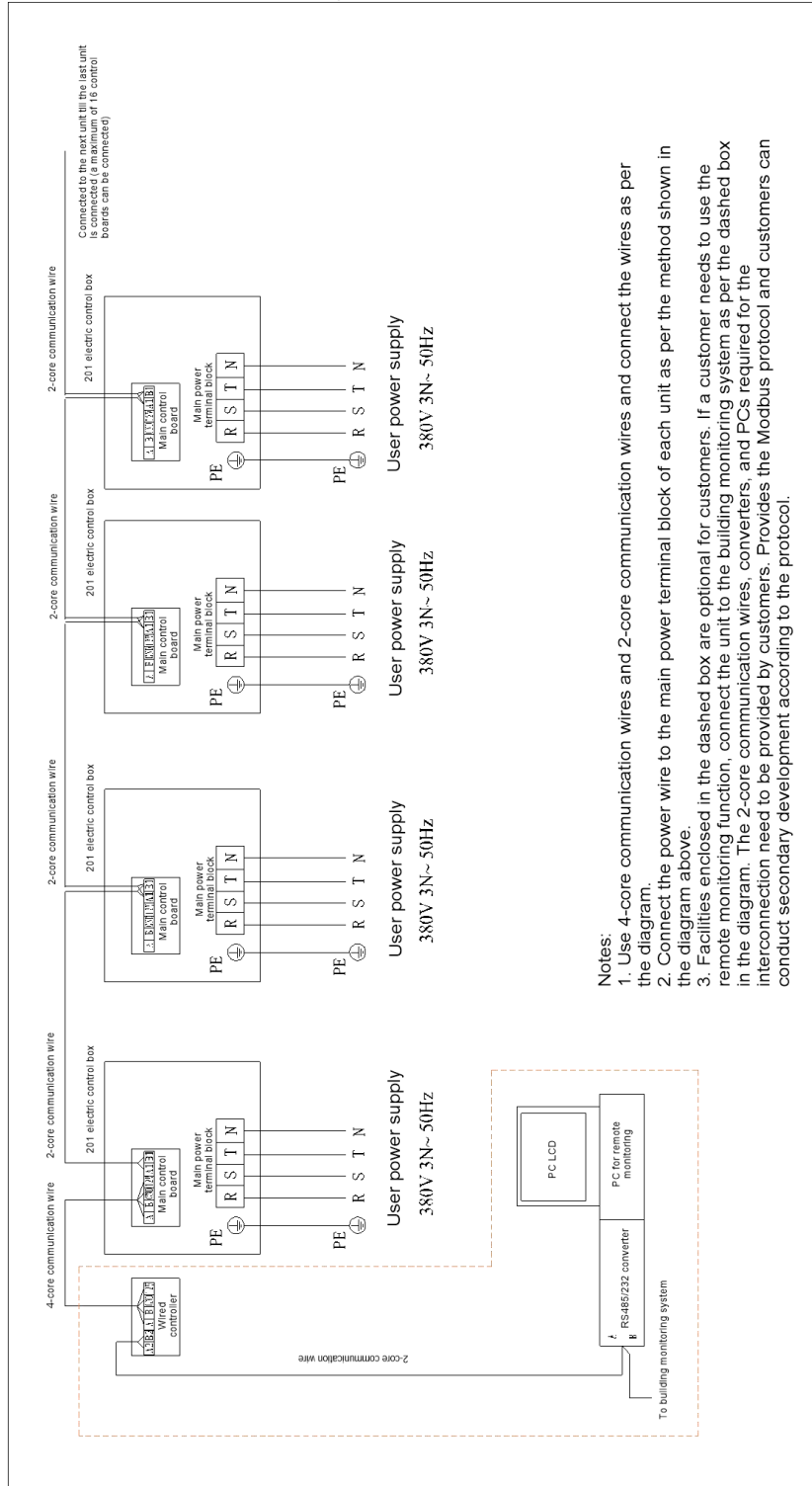

⚠ Caution

The following circuit diagrams are applicable to standard units. The circuit diagram in the manual may differ from the actual circuit diagram pasted to the unit due to product innovation and improvement. The circuit diagram pasted to the unit shall prevail.

For the wiring diagrams of other non-standard units, see the circuit diagram pasted to the unit body.

Note: The schematic diagram is subject to the actual product that comes with the unit!

VI. Unit Commissioning and Operation Description

Caution

Be sure to check the entire air conditioning unit system before powering on for trial operation. Pay attention to the following aspects:

1. Checking the air-side devices of the air conditioner

Check whether the power supply connections of all indoor air-side devices are correct and whether the fan runs properly.

Check whether check valves on the inlet and outlet of indoor air-side devices are all open.

Check whether air in the water system in indoor air-side devices is thoroughly discharged. If there is air in the FCU, open the air discharge valve to discharge the air.

2. Checking the system pipeline

Check whether the system pipeline, water refill pipeline, pressure gauge, and thermometer are installed correctly.

Check whether the static pressure on the water return of the unit is greater than 5.0 mH₂O.

Check whether the system pipeline is clean, whether the refrigerant in the pipeline is full, and whether air is thoroughly discharged.

Check whether valves that should be open are all open in the system and valves that should be closed are all closed.

Check whether proper thermal insulation and condensate drainage measures are taken for the pipeline system.

Check whether the expansion water tank and water refill device are sensitive and whether air in the water pipes is discharged thoroughly. Before starting water pumps, open the air discharge valves to check whether water flows out. If no, air is not thoroughly discharged. In this case, do not start water pumps. Check the expansion water tank and water refill system to ensure that air is discharged thoroughly. Start water pumps after confirming that the pipeline is full of water. Do not run water pumps in the case of water shortage.

Check whether the water system filter is clogged to ensure that the water line is smooth without blockage.

Check whether the water flow switch is correctly installed and whether the wiring is correct.

3. Checking the power distribution system

Check whether the power supply is consistent with that required in the manual and on the unit nameplate. The voltage fluctuation should be within $\pm 10\%$.

Check whether all the power supply lines and control lines are connected in place, whether the wires are connected correctly in accordance with the wiring diagram, whether the grounding is reliable, and whether all the wiring terminals are fastened.

Check whether the main water outlet temperature sensing probe of the unit is



MODULAR AIR-COOLED CHILLER (HEAT PUMP)

installed using a blind hole, and whether the main water outlet temperature can be sensed accurately.

4. Checking the unit

Check whether the appearance of the unit and the piping system inside the unit are in good condition after transportation and handling.

Check whether the electrical lines of the unit are correct, whether the water flow switch is installed and connected to the control loop, whether the pump contactor is interlocked with the control loop, and whether the main water outlet temperature probe of the unit is connected to a correct position.

Check whether the fan blades interfere with the fixed plate and guard net of the unit.

Caution

Only professionals can perform trial operation of the unit. Users are not allowed to commission and run the unit. Otherwise the air conditioning system may be damaged or personal injury accidents may be incurred in severe circumstances.

Pay attention to the issues in the following aspects during trial operation:

- a. After checking the entire system comprehensively and confirming that it meets the requirements, start overall trial operation. Preheat the compressor for 24 hours before trial operation.
- b. Connect to a power supply, check whether the phase sequence protection is normal, and then start the main controller (the chiller starts automatically 3 minutes later). Start the water pump. After confirming that the water pump runs properly, check whether the compressor operating current is within the normal range, whether the fan rotation direction is correct, and whether abnormal sound is generated.
- c. If the main controller displays a power failure, the phase sequence of the incoming power supply for the unit is incorrect. Interchange the power sequence only. Do not change the internal lines of the unit. Otherwise, important parts inside the unit will be damaged.
- d. Check whether the cold and hot conversion of each unit element is normal, and whether the pressure value displayed on the pressure gauge is within the normal range. Keep the trial operation of the unit for a period of time. Put the unit into normal use only after confirming that no fault occurs.
- e. Clean the water filter after trial operation, and fasten all the electrical wiring terminals again. Then, the unit can be put into normal use.
- f. Do not frequently start or stop the unit to prolong the service life of the unit.
- g. When the unit is faulty, find out the cause of the fault as per the fault causes displayed on the controller, and rectify the fault. After the fault is rectified, the controller will perform automatic detection and start relevant systems.
- h. All the protection switches have been set properly before delivery. Do not adjust them by yourself; otherwise you should bear the responsibility for any damage caused by improper adjustment.

VII. Operation Description of the Unit Controller

1. Safety Precautions

Caution

The controller of the air-cooled chiller (heat pump) is a precise assembly. Be sure to read through this controller manual carefully before performing any operation. Any misoperation may damage the unit or cause personal injury.

Pay attention to the following points during installation and use:

(1) Installation precautions

- Read through this manual carefully before installation and connect wires by referring to the wiring diagram.
- The controller must be installed on a solid plane, and keep it away from rain, static electricity, shock, or dust accumulation, which has an adverse effect on the control board and even cause the controller damage.
- Only accessories provided or specified by company can be used. Using any unauthorized accessories may result in a failure of the controller or an electric shock.
- Wiring should be conducted in accordance with the principle of separating strong electric wires from weak electric wires. The control cables should be routed separately from strong electric wires and they should be shielded. If they cannot be routed separately, keep a distance of at least 50 mm between them and take shielding measures. It is absolutely forbidden to bind strong and weak electric wires together for cabling. Otherwise, the controller may fail to work properly or may be damaged.
- Power cords must be connected reliably, they are in good contact, and the insulating layer is in good condition. Loose or broken power wires may lead to electric shocks, short circuits and even fire. Air-conditioning units must be properly grounded.

(2) Use precautions

- Do not use sharp objects when operating the unit. Do not impose strong force, lest the controller panel may be damaged. Do not twist or pull the controller's wires. Otherwise, control components may fail.
- It is necessary to use the power supply that meets requirements. The use of a substandard power supply may damage the controller.
- The controller board is supplied with a 220V AC strong power. Therefore, exercise caution when operating the controller.
- Be sure to control the running status of the air-conditioning unit through the controller. It is forbidden to insert and remove the power plug to switch on/off the unit.

(3) Maintenance precautions

- When the controller is faulty, users are not allowed to repair it at discretion but contact the manufacturer in a timely manner.
- The unit can be maintained and repaired only when the unit is powered off and the power supply is cut off.

The controller and product mentioned in this document are those used in universal environments. If a product is to be used in a harsh environment (including harsh environments with electromagnetic interference), enhanced anti-interference products need to be specified in advance. Universal products are delivered if no requirement is specified.

2. Application Scope

Air-cooled chiller (heat pump) series are modular combined air-conditioning products of company. Their control system consists of the chiller control chip (input/output), sub-board control chip, and centralized operation control panel.

This user operation manual is applicable to modular air-cooled chiller (heat pump) series.

3. System Characteristics**(1) Applicable air conditioning system**

One output water pump, one fan, one plate type heat exchanger (or shell-and-tube heat exchanger), and one compressor compose one independent energy conversion system. One module has two completely independent systems, and 1-12 (or 1-16) modules compose a modular air-cooled chiller (heat pump).

(2) Networking control

RS485 serial buses are used. Communication cables can be connected simply to implement on-site networking.

(3) Basic functions

Information display in four lines (eight Chinese characters at most in each line) in Chinese;

Water pump mode or user-defined heating/cooling operation;

Timed power-on/off function, which allows setting the weekends and three holiday time periods for the unit operation;

Automatic fault diagnosis and handling, intelligent defrosting control, and intelligent anti-freezing operation control;

Unique fuzzy energy control method and optimal load matching.

(4) Digital filtering processing is performed on all collected input signals to ensure the reliability of input signals. Output signals are buffered in multiple levels and no misoperation or jitter occurs, thereby ensuring the reliable and stable operation of the unit.**(5) Password protection permissions are used for parameter setting. All parameters that need to be set have appropriate default values, which are used at the first startup or**





when default values need to be restored.

4. Unit Operation Description

(1) Wired controller instructions

(A) Output of touch-type wired controller:

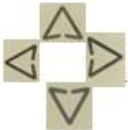

Icon	Name	Function
	Query	1) Query errors on the main interface.
	Menu	1) Tap Menu to enter the function menu on the default interface. 2) Tap Menu to return to the preceding level of menu on the setting interface or query interface.
	Directions	1) Tap the direction button on the menu interface to enter the next level of menu. 2) Tap the direction button on the setting interface to modify the parameter values or set functions.
	OK	1) Tap OK to enter the next level of menu on the menu interface. 2) Tap OK on the setting interface to confirm the parameter setting.
	ON/OFF	1) In power-on state, tap ON/OFF to shut down the unit. 2) In power-off state, tap ON/OFF to start up the unit.

Jan. 1, 2019, 12:00:00
 Unit status: Cooling
 Air conditioner water outlet:
 30.5°C/45°C
 Air conditioner water inlet:
 30.1°C/40°C
 Ambient temperature: 15.6°C

Main interface

The display screen displays current time information in the first line, the current water inlet and outlet temperatures and set values of the unit in the second and third lines respectively, and the ambient temperature of the main module in the fourth line. The operating mode area displays the setting mode of the unit (cooling ❄️, heating 🔥, water pump 🌀 or anti-freezing ❄️). When the heating symbol blinks, the system is defrosting. In the remote control status area, ♀️ is displayed if the unit is remotely controlled and the symbol is not displayed if the unit is controlled by a wired controller. In the operation status area, "Stop" is displayed if

the unit is shut down. If the water pump is started, the water pump symbol (⚙️) is displayed; if the water pump is not started, the symbol is not displayed. If the word "Ambient" blinks, the ambient temperature for unit (including submodules) operation does not meet operating conditions.

Menu interface

<p>Jan. 1, 2019, 12:00:00 Unit Operating Status Unit Port Status Modify User Parameters Modify Maintenance Parameters</p>	<p>Menu interface: Tap the up or down button to switch between menus, tap OK to enter a selected menu interface, and tap Menu to go back to the home page. Unit Operating Status page: tap Menu to go back to the menu page. Unit Port Status page: tap Menu to go back to the menu page, tap left or right button to switch between unit models, and tap up or down to display unit port information. Modify User Parameters page: tap Menu to go back to the menu page, tap up or down button to switch between menus, tap OK to enter the setting menu, tap left or right button to modify parameter value, tap OK to confirm the setting, and tap Menu to go back to the original page.</p>
<p>Jan. 1, 2019, 12:00:00 Check Unit Error Program Version</p>	<p>Modify Maintenance Parameters page: tap Menu to go back to the menu page, tap up or down button to switch between parameters, tap left or right button to change parameter value, and tap OK to confirm the setting. Check Unit Error page: tap Menu to go back to the menu page, tap left or right button to switch between unit models, and tap up or down to display unit error information. Program Version page: tap Menu to go back to the menu page, and tap left or right button to switch between unit models.</p>

Interface Function Description

Interface	Display
Main Interface	<ol style="list-style-type: none"> 1) Operating mode 2) Real-time temperature and humidity, water temperature, etc. 3) Error icon, water pump icon, anti-freezing icon, etc. 4) Error message
Unit Operating Status	<ol style="list-style-type: none"> 1) Water pump status 2) Electric heater status 3) Number of systems loaded by the compressor
Unit Port Status	<ol style="list-style-type: none"> 1) Temperature sensor values, including ambient temperature, discharge temperature, suction temperature, coil temperature, water inlet/outlet temperature, and air return temperature 2) Humidity sensor value 3) Pressure sensor value 4) Operating current of unit 5) EXV steps
Modify User Parameters	<ol style="list-style-type: none"> 1) Operating mode settings, including mode, temperature and humidity 2) Configuration parameter settings, including centralized control parameter 3) Date and time settings 4) Unit timing settings

Check Unit Error	1) Current errors 2) Historical errors
Program Version	1) Main controller program version 2) Wired controller program version

(B) Output of 7" touch screen:

A 7" touch screen is configured to implement communication between the chiller with the ODU through RS485 (COM2 port (A+, B-) of the touch screen is connected to A and B on the main board of the ODU). The touch screen needs to be powered using 24 V DC and supports programming with a USB drive.

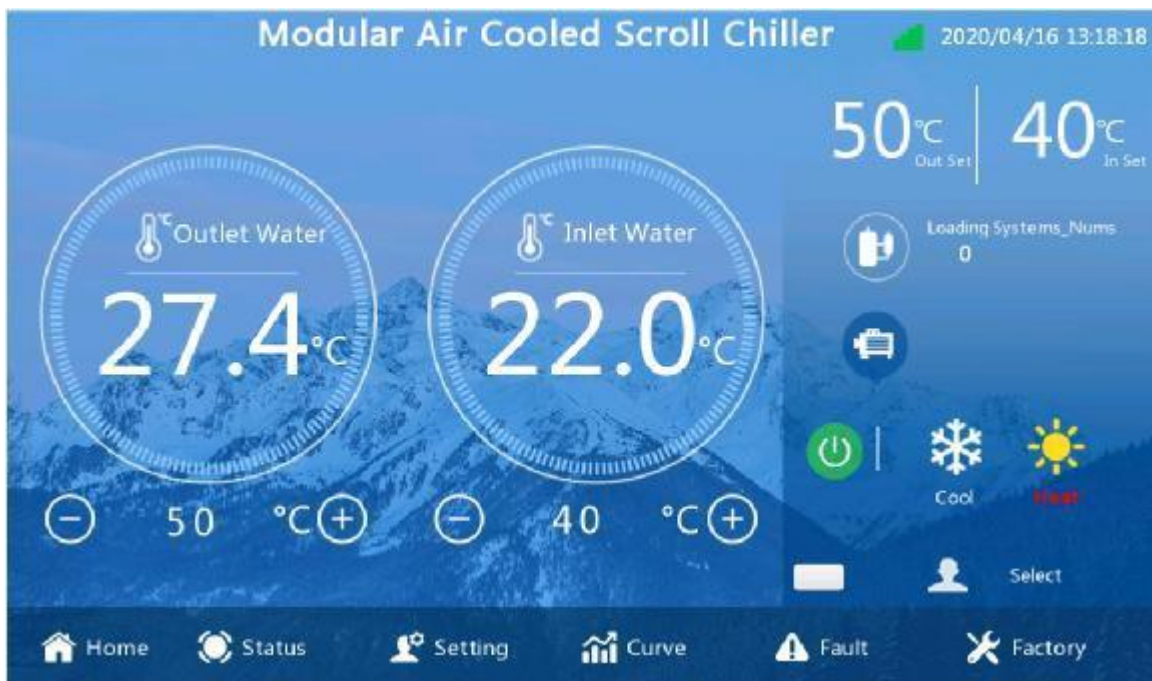
Main interface

Interface Function Description

Page	Note
Homepage	1. Homepage is the initial page after the touch screen is powered on and reset. 2. Water temperature set values and actual values are displayed. 3. Temperatures can be set. 4. The unit operating status, touch screen communication and fault can be observed; 5. Power-on/off operations can be performed.
Dropdown window	1. You can scroll down the touch screen to display this window, or scroll up the touch screen to hide this window. 2. The button operation sound can be turned on/off. 3. The time of reducing brightness of the touch screen can be selected. 4. The time of turning off backlight of the touch screen can be selected. 5. The brightness of the touch screen can be adjusted. 6. The real-time fault alarm information can be observed.

User login	<ol style="list-style-type: none"> 1. Enter the user login page through the login icon on the homepage (or the run screen); 2. The user can log in to get the corresponding operation permissions; 3. The current logged-in user can exit.
Operating status	<ol style="list-style-type: none"> 1. The unit running diagram is displayed. 2. The temperature and mode can be set. 3. Some operating parameters of the unit can be observed; 4. Power-on/off operations can be performed.
User setting	<ol style="list-style-type: none"> 1. Common functions can be set: automatic startup after power restoration, timed power-on/off. 2. Some running parameters of the unit can be viewed.
Trend curve	<ol style="list-style-type: none"> 1. The dynamic changes of set temperature and humidity and actual temperature and humidity can be observed visually. 2. The run data of the unit can be exported.
Fault check	<ol style="list-style-type: none"> 1. Current errors 2. Historical errors

(2) List of Adjustable Parameters

No.	Parameter	Default	Remarks
1	Operating mode	Cool	It needs to be manually
2	Cooling water outlet temperature	7°C	
3	Cooling water inlet temperature	12°C	
4	Heating water outlet temperature	45°C	
5	Heating water inlet temperature	40°C	
6	Defrosting module ID	1	
7	Defrosting System ID	No	
8	MODBUS address	1	Used for remote
9	Baud rate	19200	Used for remote

(3) Description of the DIP Switch on the Main Board
a. Functions of the S1 DIP Switch (TCA401XH)

S1-1		S1-2		S1-3		S1-4	
ON	Master unit	ON	Heat recovery	ON	CH290(TCA401)	ON	HP Sensor
OFF	Slave unit	OFF	Ordinary	OFF	Standard	OFF	HP Switch

b. Functions of the S1 DIP Switch (Except TCA401XH)

S1-1		S1-2		S1-3		S1-4	
ON	Master unit	ON	Heat recovery	ON		ON	HP Sensor
OFF	Slave unit	OFF	Ordinary	OFF	Standard	OFF	HP Switch

MODULAR AIR-COOLED CHILLER (HEAT PUMP)

c. Functions of the S1 DIP Switch (TCA401YHE, TCA401YH, TCA201/401YCG)

S1-1		S1-2		S1-3		S1-4	
ON	Master unit	ON	Y series	ON	\	ON	HP Sensor
OFF	Slave unit	OFF	X series	OFF	Standard	OFF	HP Switch

S1(5678) (slave unit quantity for the master unit, and slave unit address for the slave unit)					
S1-5	S1-6	S1-7	S1-8	Address	
OFF	OFF	OFF	OFF	0	Indicates a single unit.
OFF	OFF	OFF	ON	1	The addresses of slave units are 1-15.
OFF	OFF	ON	OFF	2	
OFF	OFF	ON	ON	3	
OFF	ON	OFF	OFF	4	
OFF	ON	OFF	ON	5	
OFF	ON	ON	OFF	6	
OFF	ON	ON	ON	7	
ON	OFF	OFF	OFF	8	
ON	OFF	OFF	ON	9	
ON	OFF	ON	OFF	10	
ON	OFF	ON	ON	11	
ON	ON	OFF	OFF	12	
ON	ON	OFF	ON	13	
ON	ON	ON	OFF	14	
ON	ON	ON	ON	15	

a. Functions of the S2 DIP Switch

S2(Functional DIP Switch)												
S2-1	S2-2	S2-3		S2-4	S2-5		S2-6		S2-7		S2-8	
OFF	ON	OFF	X series	OFF	OFF	Cooling only	ON	Shared air	ON	R410A	ON	Remote control
OFF	ON	OFF	YH YCG	OFF	ON	Heat pump	ON	Shared air	ON	R410A	OFF	Local control
ON	OFF	OFF	XHE	OFF	ON	Heat pump	OFF	Independent air	OFF	R22	OFF	Local control
ON	OFF	ON	YHE	ON	ON	Heat pump						

b. Functions of the S3 DIP Switch

S3-1	S3-2	S3-3		S3-4	
OFF	OFF	OFF	TCA201	ON	Compressors in parallel connection
OFF	ON	OFF	TCA401		
OFF	ON	ON			
ON	ON	OFF			

(4) Unit Configuration

Model	Refrigerant	Expansion Valve Type	Air System	Water System
TCA201/301/401XH, TCA201XHA, TCA201/401XC, TCA201XHE,TCA301XC/B ,TCA401YH,TCA401YHE TCA401XC/A、 TCA201/401YCG	R410A	Electronic expansion valve	Shared air	Shared water
TCA401XHE	R410A	Electronic expansion valve	Independent air	Shared water

(5) Failure Code List

Failure Code List			
Failure 01	Air conditioner insufficient water flow	Failure 09	Air discharge temperature high 01
Failure 02	External interlocking	Failure 10	Air discharge temperature high 02
Failure 03	Wired controller switch	Failure 11	Air discharge temperature 1#1 fault
Failure 04	Error in communication with the master unit (slave unit)	Failure 12	Air discharge temperature 2#1 fault
Failure 05	Ambient temperature fault	Failure 13	Outer coil temperature 1# fault
Failure 06	Anti-freezing temperature fault	Failure 14	Outer coil temperature 2# fault
Failure 07	Main water outlet fault (for master unit only)	Failure 15	System 1# overload
Failure 08	Insufficient domestic water flow (for master unit only)	Failure 16	System 2# overload
Failure 17	Domestic water inlet fault	Failure 25	Module water inlet temperature fault
Failure 18	Domestic water outlet fault	Failure 26	Module water outlet temperature fault
Failure 19	Water tank temperature fault (for master unit only)	Failure 27	Too low outlet water temperature
Failure 20	Heat recovery outlet temperature fault	Failure 28	
Failure 21	Indoor coil 1# temperature fault	Failure 29	Air conditioner inlet/outlet water temperature high
Failure 22	Indoor coil 2# temperature fault	Failure 30	Unrecoverable fault
Failure 23	High pressure of 1# system	Failure 31	Domestic water outlet temperature high
Failure 24	High pressure of 2# system	Failure 32	Low voltage fault
Failure 33	Air discharge temperature 1#2 fault	Failure 41	1# cooling pressure low
Failure 34	Air discharge temperature 2#2 fault	Failure 42	2# cooling pressure low
Failure 35	Misphase protection	Failure 43	1# heating pressure low
Failure 36	Open-phase protection	Failure 44	2# heating pressure low
Failure 37	System current low	Failure 45	High voltage 1# sensor fault
Failure 38	1# system current low	Failure 46	High voltage 2# sensor fault
Failure 39	1# system current high	Failure 47	Low voltage 1# sensor fault
Failure 40	2# system current high	Failure 48	Low voltage 2# sensor fault
Failure 49	Slave module 1 communication fault	Failure 57	Slave module 9 communication fault
Failure 50	Slave module 2 communication fault	Failure 58	Slave module 10 communication fault
Failure 51	Slave module 3 communication fault	Failure 59	Slave module 11 communication fault
Failure 52	Slave module 4 communication fault	Failure 60	Slave module 12 communication fault
Failure 53	Slave module 5 communication fault	Failure 61	Slave module 13 communication fault
Failure 54	Slave module 6 communication fault	Failure 62	Slave module 14 communication fault
Failure 55	Slave module 7 communication fault	Failure 63	Slave module 15 communication fault
Failure 56	Slave module 8 communication fault	Failure 64	Program and unit mismatch
Failure 65	1# compressor drive communication fault	Failure 73	1# compressor drive hardware fault
Failure 66	2# compressor drive communication fault	Failure 74	1# compressor bus voltage exception
Failure 67	Fan 1 drive communication fault	Failure 75	1# compressor out of step
Failure 68	Fan 2 drive communication fault	Failure 76	1# compressor zero speed protection
Failure 69	Vapor injection 1# temperature fault	Failure 77	1# compressor phase loss
Failure 70	Vapor injection 1# saturation temperature fault	Failure 78	1# compressor overcurrent

MODULAR AIR-COOLED CHILLER (HEAT PUMP)

Failure 71	Vapor injection 2# temperature fault	Failure 79	Reserved
Failure 72	Vapor injection 2# saturation temperature fault	Failure 80	#1 compressor drive fault
Failure 81	2# compressor drive hardware failure	Failure 89	Fan drive hardware fault
Failure 82	2# compressor bus voltage exception	Failure 90	Fan bus voltage exception
Failure 83	2# compressor out of step	Failure 92	Fan out of step
Failure 84	2# compressor zero speed protection	Failure 93	Fan startup failure
Failure 85	2# compressor phase loss	Failure 94	Fan phase loss
Failure 86	2# compressor overcurrent	Failure 95	Fan overcurrent
Failure 87	Reserved	Failure 96	Reserved
Failure 88	#2 compressor drive fault	Failure 97	Fan drive fault

VIII Unit Maintenance

Air-cooled chillers (heat pumps) are highly automated devices. Therefore, check the operation status periodically. Long-term and effective maintenance can greatly enhance the operation reliability of the unit and prolong the unit's service life.

Pay attention to the following points during maintenance and servicing:

- (1) Clean the water filter installed outside the unit periodically to ensure the cleanliness of water in the system and prevent unit damage caused by clogging of the filter.
- (2) Keep the surroundings around the unit clean and dry and ensure smooth ventilation for the unit. Clean the air-side heat exchanger periodically (once 1-2 months) to maintain excellent heat transfer effect and save energy.
- (3) Regularly check whether the water refill and air discharge devices of the water system work properly. Air may enter the system and cause low water circulation or water circulation difficulties, affecting the cooling and heating effect of the unit as well as the reliability of the unit.
- (4) Check whether wiring of the unit power supply and electrical system is secure, and whether electrical components work abnormally. If an exception occurs, repair or replace electrical components. Regularly check whether the unit is grounded reliably.
- (5) If the unit is not used for long after one running period ends, drain water out of the unit pipeline and cut off power. Fill water into the system and conduct an overall check on the unit before starting the unit again. Then, electrify the unit to preheat it for more than 24 hours, and then start the unit and put it into normal operation after confirming that everything is OK.
- (6) Check the working conditions of each component of the unit regularly and check whether the work pressure of the cooling system of the unit is within the normal range. Check whether there are oil dirt on the pipeline connectors and inflation valves of the unit to ensure that no refrigerant leaks out. Only professionals are allowed to add refrigerant. R22 can be filled in liquid or gas form. R410A and R407C are hybrid refrigerant and can be filled only in liquid form. Fill a refrigerant as per the figure below.
- (7) Do not close the water inlet/outlet valves of indoor air-side devices at will during unit operation. Otherwise, the normal operation of the unit may be affected, and the internal heat exchanger of the chiller may be damaged.

Caution

The R410A or R407C hybrid refrigerant must be emptied completely when the system leaks. After vacuumizing the system again, add refrigerant as instructed by the figure on the right side. This prevents change of the system refrigerant components; otherwise the unit operation performance will deviate, affecting the service life of the unit.

The lubricating oil used for the R410A or R407C unit is different from that used for the R22 unit. To add lubricating oil, contact the manufacturer. Do not add lubricating oil at will; otherwise the unit may be damaged.

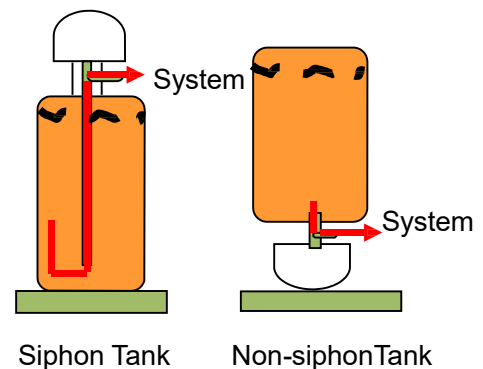

IX. Common Fault Analysis of the Unit and Handling Methods

The unit may get faulty to different degrees during use. The table below provides some common faults and their handling methods. If the unit gets faulty, the user needs to contact an authorized distributor or branch company of company and cannot try to repair it independently.

Common Fault	Cause	Solution
The compressor does not start properly and has no buzzing sounds	<ul style="list-style-type: none"> ☆ The main controller has a power failure or communication cable fault ☆ The alarm indicator of the main controller lights up ☆ The unit controller is in preheating status ☆ The main controller has wrong data settings 	<ul style="list-style-type: none"> ☆ Check whether the communication indicators are on ☆ Check the unit and contact the maintenance personnel ☆ It is normal and for protection purpose ☆ Reset the parameters based on the User Operation Manual
The compressor starts but frequently stops	<ul style="list-style-type: none"> ☆ There is too high or low refrigerant, causing too high discharge pressure or too low air suction pressure ☆ The evaporator gets frost, the water temperature declines rapidly and rises rapidly, the water circulation is poor, or the load of indoor air-side devices is low ☆ The main controller has too low temperature control cycle value 	<ul style="list-style-type: none"> ☆ Make sure the amount of refrigerant is proper; otherwise, discharge excessive refrigerant or add refrigerant ☆ If the water flow is inadequate, check whether the water line is smooth and whether the loop is too short. If the load of the air-side devices is too low, add an energy storage water tank ☆ Change the parameters on the advice of the maintenance personnel
The compressor makes a lot of noise	<ul style="list-style-type: none"> ☆ The power phase sequence of the compressor is wrong ☆ The liquid refrigerant returns to compressor ☆ The components of the compressor are faulty 	<ul style="list-style-type: none"> ☆ Check the power cord of the main power and incoming wire of the compressor ☆ Check whether the expansion valve works normally ☆ Repair or replace the compressor

Common Fault	Cause	Solution
The cooling capacity is relatively low	<ul style="list-style-type: none"> ☆ Insufficient refrigerant, insufficient cooling capacity and low evaporation temperature ☆ The thermal insulation of the water system is poor ☆ The condenser does not remove heat properly ☆ The expansion valve is not properly adjusted ☆ The filter is clogged 	<ul style="list-style-type: none"> ☆ Repair leaking points and add refrigerant ☆ Strengthen thermal insulation of the pipeline and expansion water tank ☆ Clean the condenser and improve condensing conditions ☆ Adjust the expansion valve ☆ Replace the filter
The intake duct of compressor is frosted	<ul style="list-style-type: none"> ☆ The chilled water flow is too small ☆ The water line is blocked or air is not discharged thoroughly 	<ul style="list-style-type: none"> ☆ Check whether the water pump motor matches the unit ☆ Unclog the water line or empty air
Too high condensation pressure	<ul style="list-style-type: none"> ☆ Too much refrigerant ☆ The ambient temperature is too high and the unit is not well ventilated ☆ There is air or non-condensable gas inside the refrigerant or the system 	<ul style="list-style-type: none"> ☆ Discharge excessive refrigerant ☆ Rule out other contributory factors and improve condensing conditions ☆ Discharge air or non-condensable gas through air outlet
Too low condensation pressure	<ul style="list-style-type: none"> ☆ Insufficient refrigerant ☆ There is something wrong with the valve plate of the compressor, thus reducing efficiency 	<ul style="list-style-type: none"> ☆ Check and repair the leaks, and add refrigerant ☆ Replace the compressor
Too high air suction pressure	<ul style="list-style-type: none"> ☆ Too much refrigerant ☆ The return water temperature is high and the heating load is high ☆ The opening of the expansion valve is too large 	<ul style="list-style-type: none"> ☆ Discharge excessive refrigerant ☆ Reduce the chilled water flow and reduce the heating load ☆ Adjust the expansion valve

<p>Due to too low air suction pressure, low voltage protection frequently occurs</p>	<ul style="list-style-type: none"> ☆ Insufficient refrigerant ☆ The return water temperature is low and the indoor air-side device is faulty ☆ The expansion valve has too small opening or is clogged 	<ul style="list-style-type: none"> ☆ Check and repair the leaks, and add refrigerant ☆ Rectify the fault occurring on the air-side device and unclog the water line ☆ Adjust the expansion valve
--	---	---

Common Fault	Cause	Solution
The unit cools properly but does not heat	<ul style="list-style-type: none"> ☆ The operating conditions of air-conditioning are improperly selected ☆ The four-way valve has loosened wires or burned or stuck coils ☆ Due to low temperature, the fin-type heat exchanger is frosted 	<ul style="list-style-type: none"> ☆ Check whether the operating conditions of air-conditioning are improperly selected ☆ Repair the four-way reversing valve ☆ Remove frost and add auxiliary heat source
The compressor rotates continuously while heating	<ul style="list-style-type: none"> ☆ The temperature sensing probe of the water temperature controller is damaged ☆ The temperature set value is too high and the water temperature cannot reaches the set value ☆ The system has low heating efficiency 	<ul style="list-style-type: none"> ☆ Replace the temperature controller ☆ Set the hot water temperature again (45°C recommended) ☆ Add auxiliary heat source if the ambient temperature is too low
The water pump does not work when the main controller is started	<ul style="list-style-type: none"> ☆ The power supplied to the water pump power wire in the customer control cabinet is unavailable ☆ The water pump motor burns out and the bearing is damaged 	<ul style="list-style-type: none"> ☆ Locate the line fault ☆ Replace the water pump motor, bearing, and shaft seal

Caution

The following circumstances are normal phenomena:

When the temperature reaches the set value during unit operation, the unit stops running automatically. After the temperature rises, the unit re-starts automatically according to the preset operating mode.

When the outdoor temperature is low and the humidity is relatively large, the outdoor heat exchanger may frost during operation of the unit. To ensure normal operation of the unit, the microcomputer controller of the unit will make judgment according to the time and temperature and enter

the defrosting process automatically. After defrosting ends, the unit will restart operation automatically according to the operating mode set by the user.

X. After-sales Service

- If repair and maintenance service is needed, call the 400 service hotline.

Caution

Improper maintenance or repair may cause water leakage, electric shocks or fire. Ask authorized seller or service personnel for help when the unit needs to be moved or re-installed.

- Warranty

Warranty details are subject to the order contract.

XI. Other Information

A separate "control accessory box" contains a remote controller, a remote controller communication cable, temperature sensor blind pipe, main water temperature sensor, installation operation manual, and other components. Trial operation can be carried out only after correct installation on site.

1. Installation of the Remote Controller

I. Installation of 120 touch-type wired controller display

1. Open the wired controller junction box. Take out the wired controller and the screws that come with it.
2. Push the backplane on the rear side of the wired controller in the direction of the arrow to remove it.

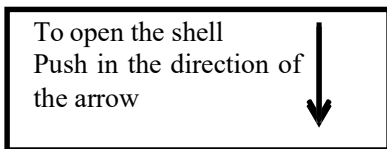

3. As shown in the following figures, pull out the connecting wire of wired controller from the embedded junction box (prepared by the user; 86mm×86mm junction box is recommended) and through the backplane of the wired controller. Then, connect the connecting wire to the plug-in terminal.

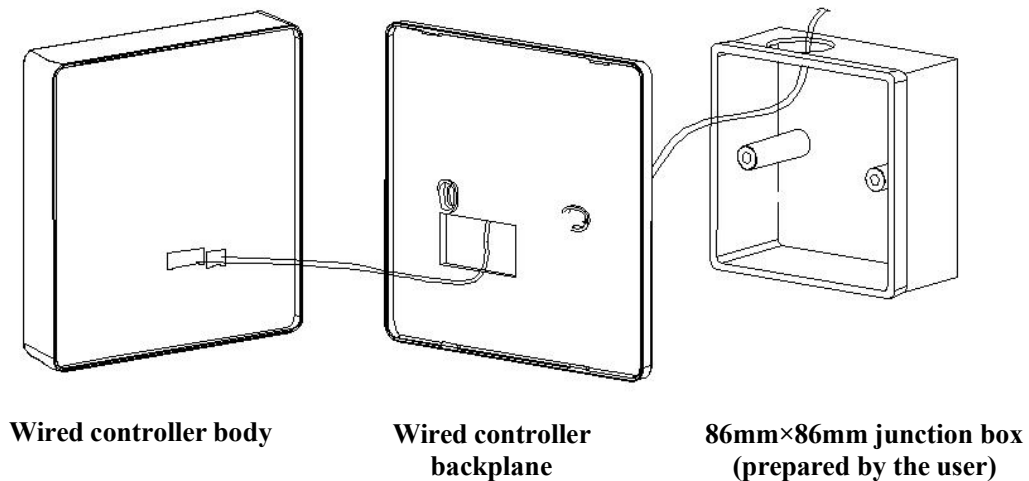

4. Install the backplane onto the 86mm×86mm junction box (prepared by the user), as shown below.

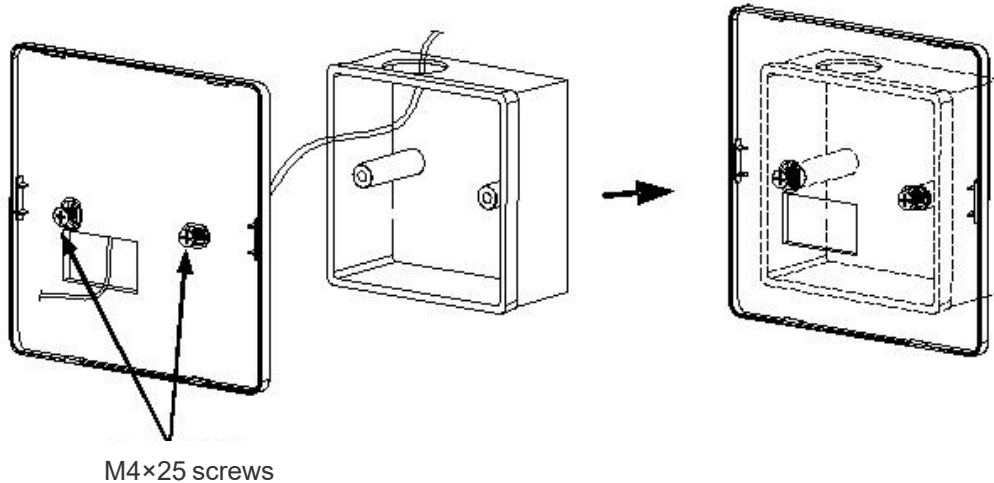

5. Install the wired controller body back to the backplane (in the opposite direction of removing).

If installation of a junction box in a concealed wall is impossible, the user needs to purchase a 86mm×86mm exposed junction box for installation.

II. Installation of 7" touch screen

When the remote controller is installed inside the control cabinet in the equipment room, install the remote controller as follows:

Step 1:
Open a hole on the metal panel of the control cabinet for installing the remote controller.

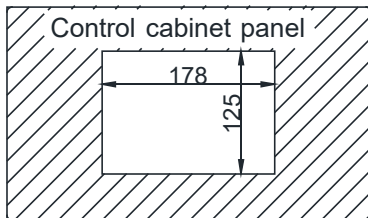

Step 2:
Embed the controller on the panel of the control cabinet.

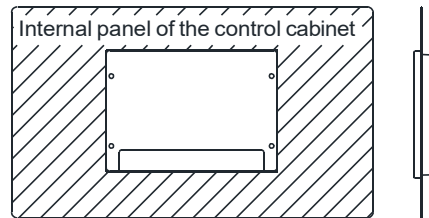

Step 4:
The controller installation is complete.

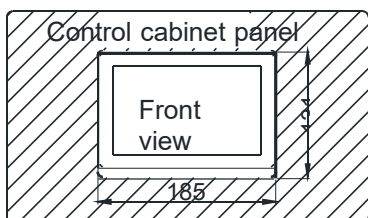

Step 3:
Use a screwdriver to rotate out the fixing clip and press it against the control cabinet panel.

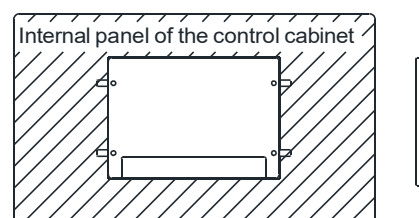

When the remote controller needs to be installed on the wall, install it as follows:

Step 1:
Select a proper position for installation, open a hole on the wall or installation board as shown in the figure below, install the M6 fastening bolts, and tighten the bolts. Ensure that the bolts protrude out of the wall for about 2 mm.

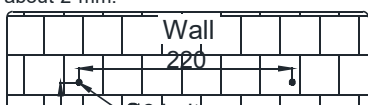

Step 2:
Align the large holes of installation holes on the rear side of the controller box with the fastening bolts.

MODULAR AIR-COOLED CHILLER (HEAT PUMP)

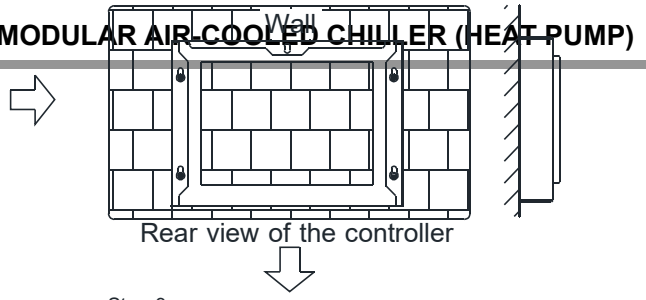

Step 4:
The controller installation is complete.

Step 3:
Level the control box, pull down the control box, and trap the fastening bolts in the upper small holes of control box.

MODULAR AIR-COOLED CHILLER (HEAT PUMP)

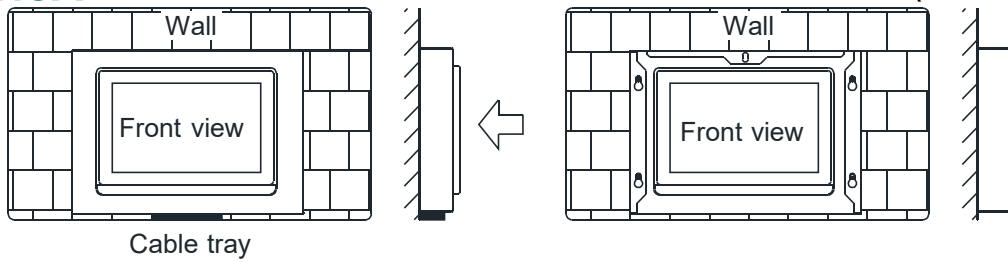

2. Auxiliary Electric Heater

(1) Characteristics

- a. The operation of the auxiliary heater is controlled intelligently. When the ambient temperature is low, the microcomputer automatically starts the auxiliary heating program to compensate for the heating lack caused by heat attenuation due to low ambient temperature. It increases the heat output and makes the unit work in an operating condition closer to the standard operating condition, thereby improving the operation efficiency of the unit and prolonging its service life. When the indoor temperature reaches the set value, the auxiliary heater automatically stops based on the set temperature, to save energy.
- b. The small-sized auxiliary electrical heater occupies less space and is easy to install.
- c. The auxiliary heater is equipped with an overheating control component, which can effectively prevent damage to the heating tube in case of dry burning.
- d. The operating conditions are harsh because of low water temperature in winter. After the unit is restarted, compressor slugging and oil sling may be caused easily, leading to unit faults and affecting the service life of the unit. The use of the auxiliary electric heater can raise the water temperature and ensure the normal and efficient operation of the unit.
- e. The auxiliary electric heater can supplement some heat loss caused by defrosting during unit operation in winter.

The following table lists the power of the auxiliary electric heater at different atmospheric temperatures for reference (unit: kW).

Outdoor Temperature °C	8	6	4	2	0	-2	-4	-6	-8
20					0.15	0.25	0.35	0.45	0.5
18						0.15	0.25	0.35	0.4
16							0.15	0.25	0.3
14								0.15	0.2

Remarks:

- a. Auxiliary electric heaters are not required for cells left blank in the table in terms of energy balance. However, in order to ensure smooth operation of the chiller and prolong the service life of the chiller, it is recommended that auxiliary electric heaters be configured when the outdoor atmospheric temperature is lower than or equal to 2°C.
- b. If an auxiliary electric heater is required, the power of the auxiliary electric heater cannot be smaller than 0.2 kW/kW. Otherwise, when the ambient temperature is low, the heat loss of the water system may be greater than the heat output of the electric heater. As a result, the heater fails to deliver the desired effect.
- c. The data listed in the table above is the power of auxiliary electric heaters per kW heating capacity at relevant indoor and outdoor temperatures.

(2) Installation and Use Description

When the air-cooled chiller (heat pump) runs in heating mode in winter, its heating capacity declines with the drop of the outdoor ambient temperature. Auxiliary electric heaters are installed to facilitate the operation of the air-cooled chiller (heat pump). An auxiliary electric heater is connected to the water outlet pipeline in parallel during engineering project. See the figure below.

The electric control cabinet for an auxiliary electric heater is not configured at unit delivery. Only the electric heating output signal is configured and the startup cabinet needs to be provided by customers. For the wiring of the electric heater, see the circuit diagram delivered with the electric heater. One end of AC contactor coil of the electric heater needs to be connected to the electric heater terminal in the electric control cabinet of the chiller module (for details, see the wiring diagram of the unit).

Note: Company does not provide auxiliary electric heaters for standard units. Please specify the auxiliary electric heater in the order if required. The startup electric control cabinets for auxiliary electric heaters need to be provided by customers.

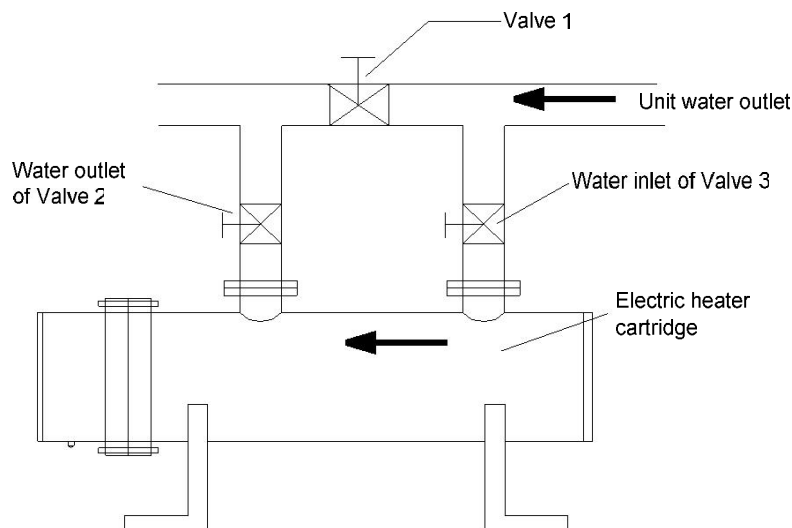

When the unit runs in cooling mode in summer, open Valve 1 and close Valve 2 and Valve 3 to reduce the loss of the water pressure drop on the pipeline. In this way, chilled water of the unit will not flow through the auxiliary electric heater. When the unit runs in heating mode in winter, open Valve 2 and Valve 3 and close Valve 1. In this way, hot water flowing out of the unit flows through the auxiliary electric heater, and supplements heat into the hot water of the unit to raise the water temperature after the unit is electrified. The hot water is supplied to the air-side devices.

 Caution

Open water valves of the unit during commissioning. Open the circulating water pump to discharge air out of the system. Then, electrify the unit for commissioning so as not to burn electric components. If the electric heater is not used, drain water out of the electric heater cartridge to prevent cartridge freezing or rust.

3. Interlock Controller

A standard unit is equipped with an interlock control interface at delivery. Customers can select an interlock controller and connect wires correctly to implement interlock control between indoor air-side devices and the chiller. A single interlock controller can control 8 air-side devices in an interlocked manner, two interlock controllers can accommodate 15 air-side devices, and so on.

Note: The relevant bit on the DIP switch of the unit needs to be turned to remote control position.

If an interlock controller needs to be used, a temperature controller must be used for the air-side devices.

The figure below shows the wiring between the chiller and air-side devices when an interlock controller is used to implement interlocked control between the chiller and air-side devices.

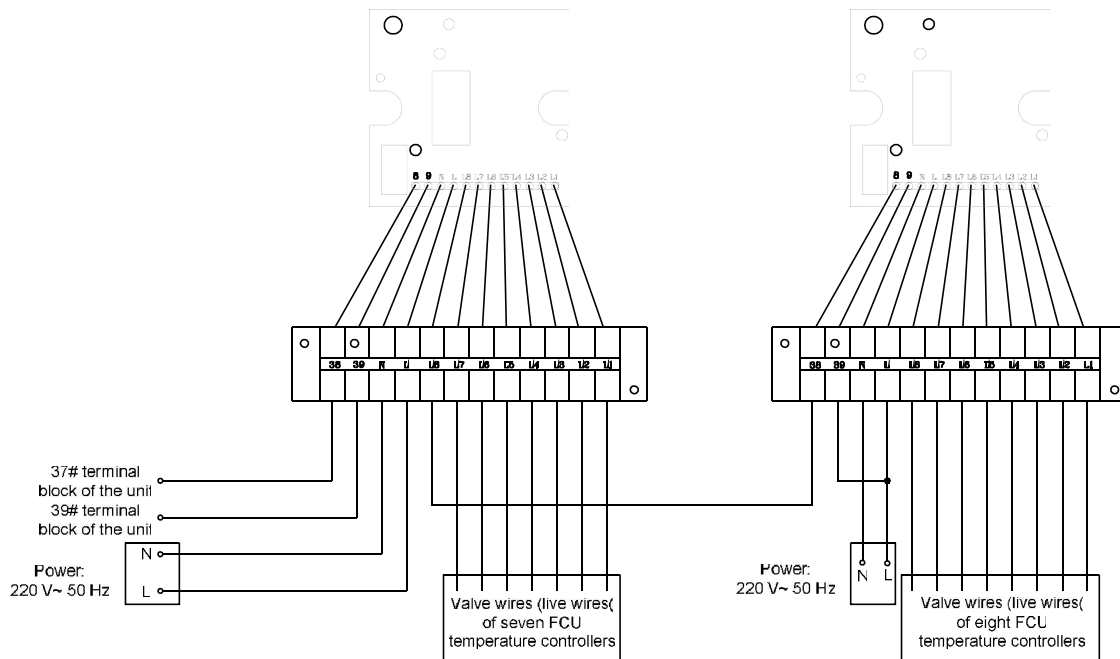

The figure above is the wiring diagram of two interlock controllers and the wiring of multiple interlock controllers is similar to the wiring in the figure above.

Caution

Interlock controllers are not equipped for standard models at delivery. The wired control switch is short-connected to the common line. If an interlock controller needs to be connected, remove the short connection wire and connect wires as per the circuit diagram above.

4. Installation Description of the Main Water Outlet Temperature Sensing Probe

Currently, the main water pipe of a modular unit is installed by engineers on site. Therefore, the main water outlet temperature sensing probe must also be installed on the main water

pipe on site, so as to truly reflect the water outlet temperature of the unit and make the unit work properly. The following provides details of installing a water outlet temperature sensing probe.

The main water outlet temperature sensing probe of the unit is in the control accessory box. Take the probe out of the box and install it correctly.

To reflect the water outlet temperature more accurately, it is necessary to open a hole on the main water outlet pipe and weld and seal the blind pipe (accessory) for heat conduction. Apply thermosensitive adhesive to the internal side of the blind pipe and insert the water outlet temperature sensing probe into the blind pipe.

After the water system is installed completely, open a hole close to the main module on the main water outlet pipe, insert the water outlet blind tube, and weld and seal the water outlet blind tube. Ensure that the temperature sensing probe can accurately sense the water temperature in a timely manner.

Schematic diagram of on-site blind tube installation

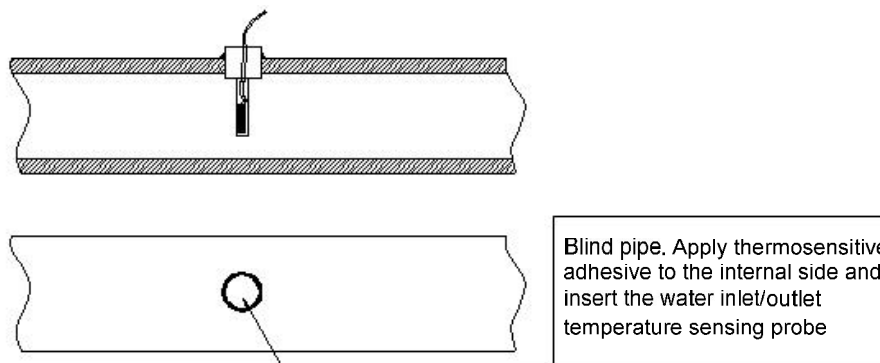

Caution

Make sure that the temperature sensing part of the water outlet temperature sensing probe is deeply inserted into the bottom.

5. Description of the Connection Between the Temperature Sensing Probe/Water Pump and the Chiller

The water temperature sensor, 30 m controller connection cable, and water pump control output cable in the accessory box need to be connected to the control board of the chiller prior to commissioning. The wiring method is as follows:

A. The figure below shows the wiring between the wired controller/30 m controller connection cables and the control board in the chiller control box.

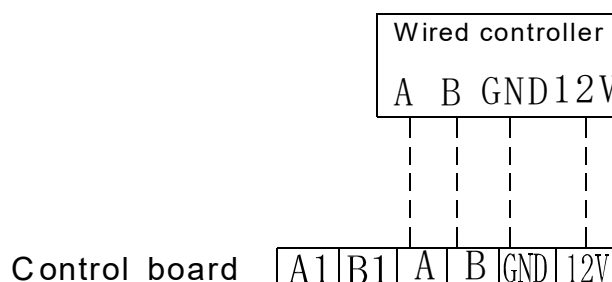

B. The water pump control point needs to be connected to Terminal 47 and Terminal 48 inside the chiller control box during on-site installation.



6. Environmental Protection Description

- This product complies with the environmental protection requirements of the Measures for the Administration of the Restricted Use of the Hazardous Substances Contained in Electrical and Electronic Products.
- Environmental protection service life: In the environmental protection service life, the user's normal use of this product will not cause serious pollution to the environment or cause serious damages to persons and properties. The service life is specified by TICA. The environmental protection service life is not equivalent to the service life of safe use.
- Recycling: When this product is not needed or its service life ends, recycle it according to the related national regulations on recycling of waste electrical and electronic products. Do not discard it at will.
- **Names and content of hazardous substances in products**

Part name	Hazardous substance					
	Plumbum (Pb)	Mercury (Hg)	Cadmium (Cd)	Hexavalent chromium (Cr(VI))	Polybrominated Biphenyls (PBB)	Polybrominated Diphenyl Ethers (PBDE)
Compressor and its	×	○	×	○	○	○
Refrigerant	○	○	○	○	○	○
Fan motor	×	○	○	○	○	○
Heat Exchanger	×	○	×	○	○	○
Pipeline fittings and valves	×	○	×	○	○	○
Screws, bolts, and other	○	○	○	×	○	○
Other metal parts	×	○	○	×	○	○
Controller and electrical	×	○	×	○	○	○
Sponge	○	○	○	○	○	○
Foam	○	○	○	○	○	○
Other plastic parts	○	○	○	○	○	×
Rubber parts	○	○	○	○	○	○

Electric heating components	×	○	○	○	○	○
Other printed matters	○	○	○	○	○	○
Accessories (remote controller, battery)	○	○	○	○	○	○

This table is prepared according to the provisions of SJ/T 11364.

O: It indicates that the content of this hazardous substance in all homogeneous materials in this part is below the limit requirement defined in GB/T 26572.

×: It indicates that the content of this hazardous substance in at least one homogeneous material in this part exceeds the limit requirement defined in GB/T 26572. Moreover, substitution cannot be implemented at present due to technical reasons, and it will be improved gradually along with technical progress in the future.

*: It indicates that the environmental protection service life of the battery matched with the product is 2 years.



The number in this identification indicates that the environmental protection service life of the product under the normal use status is 15 years. Some parts may also have the identification of environmental protection service life, and their environmental protection

service life is subject to the number in the identification. The product configuration may be different due to different models or product improvements. The actual configuration of sold products should prevail.

Warning

The copyright of this user manual belongs to company. No part of this document may be copied, duplicated, or extracted without prior consent or authorization. Company reserves the right to legal proceedings.



TICA PRO LLC

141014, Russia, Moscow oblast, Mytishchi,
Very Voloshinoy Ulitsa, office 705 and 805

Tel.: +7(495)822-29-00

E-mail: info@tica.ru

www.tica.ru