

PRODUCT OVERVIEW



TW-CLASS WATER-COOLED CHILLERS WB design series



SMARTD
GLOBAL #1 IN OIL-FREE CHILLERS

T^W-Class Water-Cooled Chillers

The T^W-Class of chillers is Smardt's water-cooled chiller that utilize Smardt's oil-free magnetic bearing technology with Turbocor's TT/TTS series compressors. The T^W-Class WB series of chillers are available from 85 to 1140 TR (298 to 4009 kW) and can be supplied in multiple configurations, which Smardt can customize per the requirements of your application.



A Smardt T^W-Class WB series chiller equipped with two compressors.

T^W-Class WB Series

Smardt has brought its extensive experience in oil-free chiller development, sales and service into designing the T^W-Class — a range of water-cooled chillers that deliver the highest level of reliability, outstanding efficiency and the lowest total cost of ownership.

T^W-Class chillers offer valuable benefits to owners and operators, such as ease of installation, simple streamlined operation and maintenance, and lower lifetime operating and maintenance costs. These advantages are the hallmark of Smardt chillers.

Smardt's water cooled chiller products include our T^W-Class and V-Class chillers. Your requirements for capacity, configuration, and turndown performance will help your Smardt representative assist with determining the best product fit for your project.

The WB series was the first design series of Smardt's T^W-Class. The WE series was developed to provide more options to meet an increasing variety of project requirements and owner needs.

Global Number One

Smardt is the industry leader in oil-free centrifugal chillers. Smardt pioneered oil-free centrifugal compressor technology to provide plant owners and operators a line of chillers that surpassed industry norms of lifetime performance, energy conservation (reducing operating expenses), streamlined maintenance, and ease of operation.

The largest oil-free chiller in the world is a Smardt chiller, and our oil-free chillers are installed in countries across the globe. This is why we are "the global number one" in oil-free chillers.

Oil-Free Operation

Smardt oil-free centrifugal compressors use magnetic bearings and a variable-speed drive to deliver IPLV efficiencies that far surpass those of conventional oil-lubricated centrifugal, reciprocating, scroll and screw compressors.

Smardt utilizes totally oil-free Turbocor technology, achieving the highest part-load efficiencies for our chillers and chilled water systems (including water-, air- and evaporatively-cooled applications).

Proprietary magnetic bearings replace conventional oil-lubricated bearings. This eliminates the high friction losses, mechanical wear, and the higher-maintenance oil management systems that are inherent with conventional compressor designs.

Turbocor's primary moving part (the rotor shaft and impellers) is levitated during rotation by a digitally controlled magnetic bearing system. Position sensors at each magnetic bearing provide real-time feedback to the bearing control system, 120 times each revolution, ensuring constantly centered rotation.

Smardt's oil-free operation yields chiller energy savings of 35 percent and more compared to standard chillers, while ensuring long-lifecycle reliability.

T^W-Class WB Series Chillers



T^W-Class WB Series Chillers

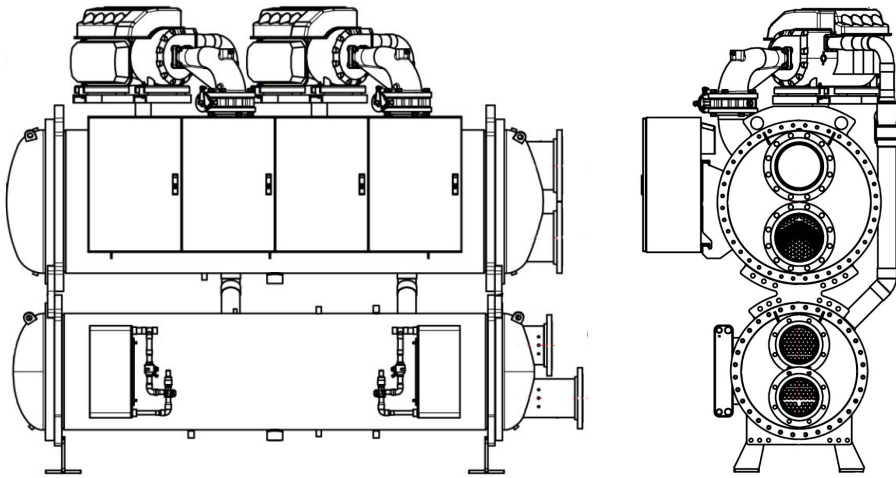

Side and front views of a Smartd T^W-Class WB series chiller customized in a stacked configuration to fit a smaller footprint within a plant room.

Turbocor TT Compressor

T^W-Class WB series chillers can be equipped with up to eight oil-free compressors. VFDs are built-in, and drives are internal to the machine. These oil-free compressors have low-sound output and use environmentally friendly R134a or R-513A refrigerants.

Configurations

Smartd can configure your T^W-Class WB series chiller to fit any footprint, with multiple barrel configurations available.

Applications

Energy conscious plant owners and operators want optimized performance with savings over the life of the chiller. Smartd's T^W-Class WB series chillers support critical-load applications in a variety of markets, including commercial, data center, pharmaceutical, hospital, higher education, district cooling, hotels, malls, and manufacturing.

Highlights

- Largest capacity range in oil-free water-cooled chillers.
- Typically smaller footprint than chillers of comparable capacity.
- Responsive chilled water control under all conditions.
- Inbuilt redundancy with multiple compressors.
- Class leading part-load efficiencies, achieving optimum IPLV in total capacity range.
- Designed for ease of maintenance and serviceability, featuring field-serviceable compressors.
- Smartd quality, acceptance tested and pre-commissioned prior to delivery ensuring trouble-free commissioning and start-up on every project.

T^W-Class WB Series Chillers

Smardt's T^W-Class WB series of chillers with full-load capacities of units with R134a refrigerant, range from 85 to 1140 TR (298 to 4009 kW)

Base Models

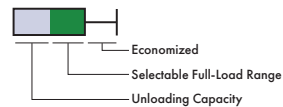
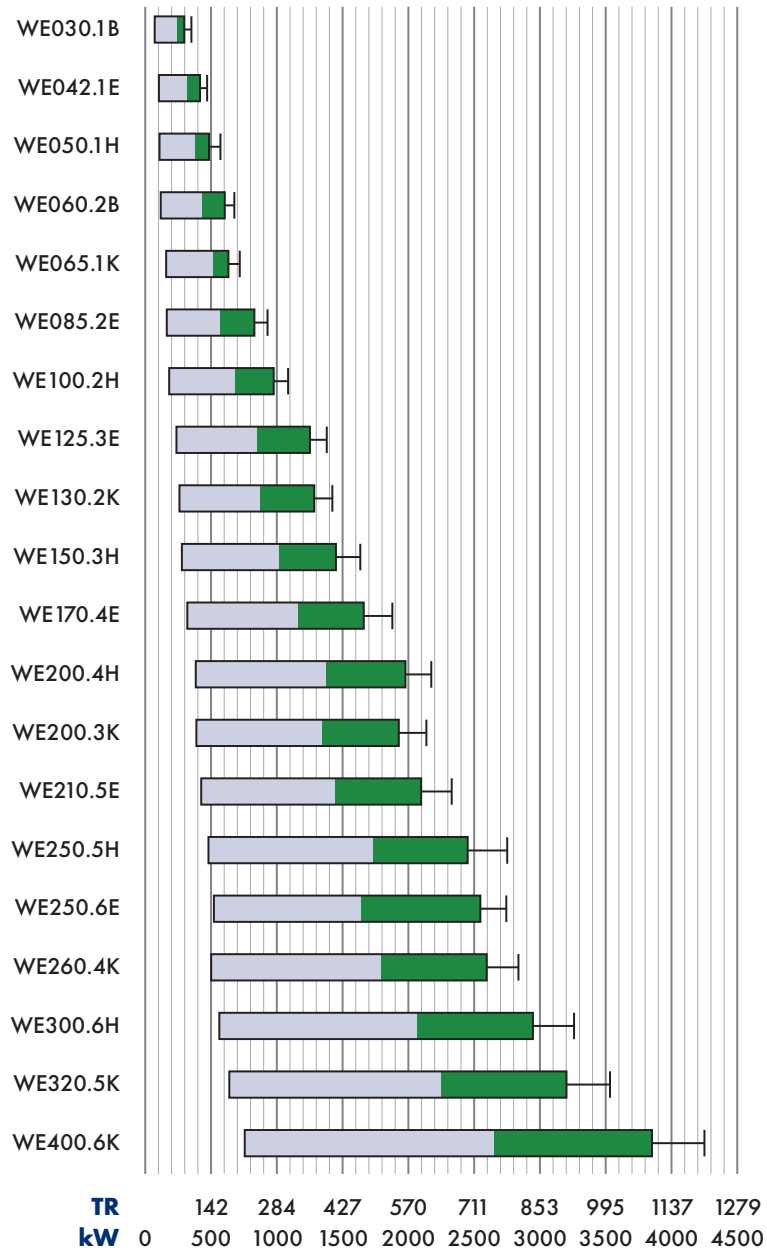

Note: Available cooling capacity will vary with operating conditions and chiller configuration. Capacities shown are based on standard AHRI conditions.

T^W-Class WB Series Chillers

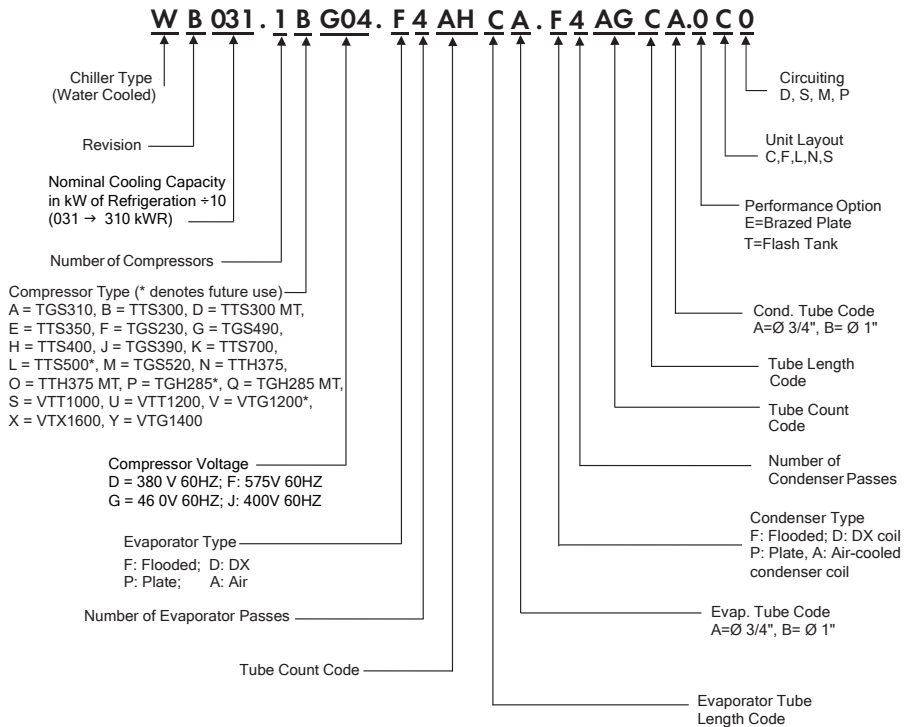

Model nomenclature for the Smardt T^W-Class WB series chiller.

About Smardt

The Smardt team shares more than 25 years' experience working with magnetic bearings and oil-free centrifugal chillers. Smardt was founded in 2005 by Turbocor founder, Roger Richmond-Smith. Accordingly, Smardt has worked with Turbocor technology longer than any other HVAC manufacturer in the world.

Global reach, single focus

The Smardt Chiller Group is both the pioneer and world-leader in oil-free centrifugal chillers, with production facilities in Canada (Montreal area),

Australia (Melbourne area), United States (Plattsburgh, New York), Germany (Stuttgart area), and China (Guangzhou).

Smardt service networks extend across the globe to monitor and support the world's largest installed base of oil-free high-efficiency chillers, with more than 9000 chillers installed globally.

Global reach, single focus

Smardt is both the pioneer and world-leader in oil-free centrifugal chillers, with production facilities in Canada (Montreal area), Australia (Melbourne area), United States (Plattsburgh, New York), Germany (Stuttgart area), and China (Guangzhou).

Smardt service networks extend across the globe to monitor and support the world's largest installed base of oil-free high-efficiency chillers, with more than 9000 chillers installed globally.

«TICA PRO» LLC

Tel: +7 495 127 79 00, +7 915 650 85 85, +7 969 190 85 85

E-mail: info@tica.pro

www.tica.pro



All Smardt chillers are ETL-listed. Electrical safety for the life of the chiller is a fundamental requirement throughout the company. Smardt evaporators and condensers conform to the ASME pressure vessel codes.

Smardt G-Class energy efficiency performance is certified according to AHRI standard 551/591, as is confirmed by AHRI on its website www.ahrinet.org. The IPLV performance of its chillers always exceeds minimum levels set out by ASHRAE standard 90.1, CSA 743, Eurovent, Australia's MEPS, China's CRAA and others, usually by a very considerable margin. Smardt, in company with the majority of the HVACR industry's leading engineers, considers the use of full-load energy efficiencies to predict any chiller's actual year-round energy-efficiency under US comfort-cooling conditions to be totally misleading, and therefore discourages their use.

Witness tests can be arranged on appropriate notice and for an appropriate fee on Smardt's AHRI-certified test stands in Montreal, Canada; Melbourne, Australia; Plattsburgh, USA and Guangzhou, China.

SMARTD *T^W-Class water-cooled chillers, WB design series*