

PRO  
TECHNOLOGY

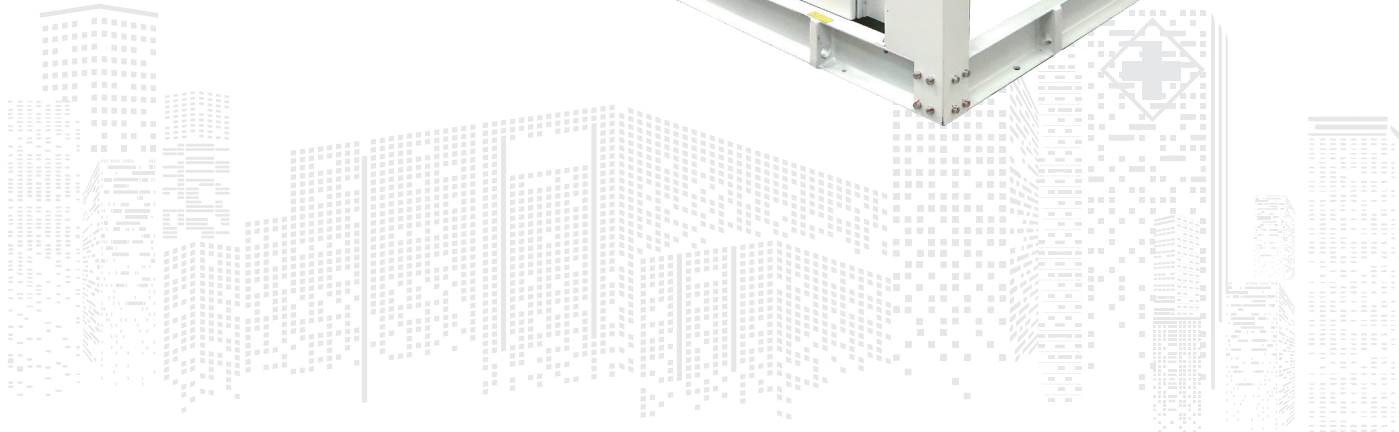

# Air-cooled Flooded Screw Chiller

## TASF Series



# Established in 1991

TICA is a professional enterprise specialized in R&D, manufacturing, sales and services of environment cleaning and thermal energy utilization.

TICA is a national high-tech enterprise, a single leading enterprise cultivated by the Ministry of Industry and Information Technology, a national brand cultivation enterprise of the Ministry of Industry and Information Technology, and a vice chairman member of China Refrigeration and Air-conditioning Industry Association. It has a national-recognized enterprise technology center, an enterprise academician workstation, and a post-doctoral research workstation. Its projects cover Beijing Bird's Nest Stadium, Water Cube, Wukesong Indoor Stadium, PetroChina, Sinopec, State Grid, Nanjing Panda, Hangzhou Xiaoshan International Airport, Hainan Airlines Group, Shangri-La Hotel, Manila Ocean Park, Abu Dhabi Al Muneera, SM City in Philippines and Unilever, etc.

TICA is also the outstanding provider of central air conditioners for China's subway networks and has successfully served nearly 60 key subway lines in major cities such as Beijing, Shanghai, Guangzhou, Shenzhen, Chengdu, Suzhou, Hangzhou and Tianjin. TICA is a professional supplier and service provider in China that specializes in system integration of clean environment. While for microelectronics, hospital operating rooms, biopharmaceutical industry and other professional purification areas, our market share has achieved over 40% in each.

## TICA Quality For IAQ

TICA focuses on indoor air quality (IAQ) in clean environments. Product lines include return air purifiers, heat recovery ventilators, fresh air purifiers, air purifiers, as well as the clean air handling units and digital variable-capacity air handling units used in the professional purification field. Regarding core technology, TICA established an ISO class 1 super-clean environment integration system and won the first prize of CMIST.

TICA's product lines include modular chillers, VRF units, screw chillers, centrifugal chillers, and ORC low-temperature waste heat power generation systems. In 2015, TICA and United Technologies Corporation (UTC) established a global strategic joint venture cooperation relationship and acquired PureCycle, an ORC low-temperature power generation company owned by Pratt & Whitney under UTC. TICA obtained PureCycle trademarks and more than 100 patents and national copyrights. TICA's efficient centrifugal chillers, water-cooled screw chillers, and air-cooled screw chillers are manufactured with the technical license of Carrier under UTC.

TICA is characterized by excellent system integration capability. In the application of "Efficient Refrigeration System of Underground Railway Station", the integrated COP of the refrigeration room amounts to 6.0, and the research achievement reaches the international advanced level. In 2018, TICA merged and acquired an OFC central air conditioning enterprise **SMARTD**. TICA's excellent system integration capability and the **SMARTD** OFC water chillers help increase the integrated COP of the efficient equipment room to 6.7 to 7.0.

TICA---We're striving.

TICA aims to build itself into a world-leading system integration supplier and service provider that specializes in clean environment and thermal energy utilization.



Nanjing Plant



Guangzhou Plant



Tianjin Plant



Chengdu Plant



Kuala Lumpur Plant



Smartd HQ, Montreal



Energy Base

## Content

Page

- Product Overview ..... 2
- Features ..... 3
- Specifications ..... 6
- Dimensions ..... 16
- Installation ..... 18
- Routine Maintenance ..... 25

# Product Overview

TASF series air-cooled flooded screw chiller is equipped with an R134a special high-efficient twin-screw compressor, a flooded evaporator, a unique oil return technology, an economizer for circulation, and so on. Besides its chilling parts and control components that are all products of international well-known brands, the unit is also provided with a solution for intelligent control. The product, which has the characteristics of high efficiency, energy conservation, stability and reliability, etc., is widely used in many comfortable and technological places such as hotels, hospitals, office buildings, shopping malls, apartments and factories.



## Nomenclature

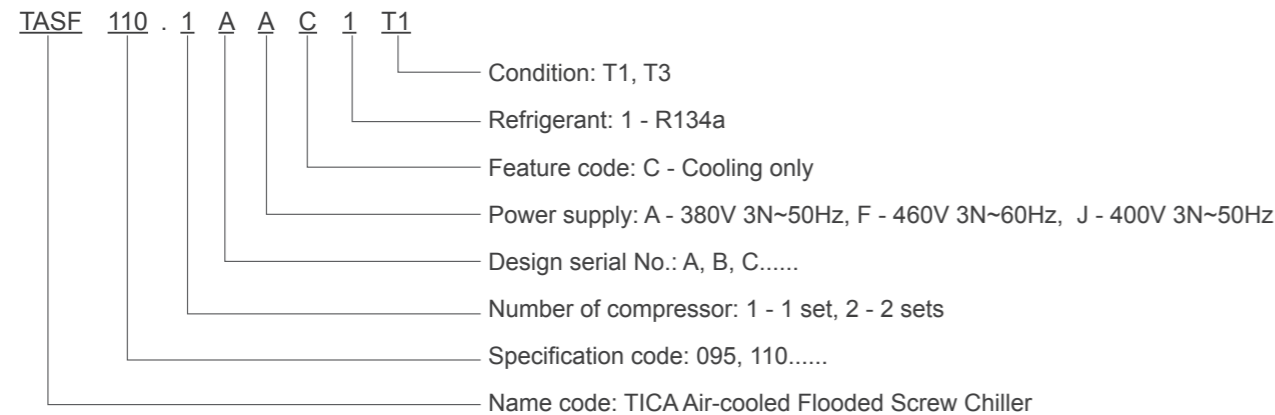

## Operating range

Operating range				
Model	Water leaving temperature (during operation)	Ambient temperature	Voltage	Water flow
TASF-AAC1T1	4°C-20°C	5°C-45°C	360V-400V	50%-120% of the nominal water flow
TASF-AJC1T1			380V-420V	
TASF-AAC1T3		5°C-52°C	360V-400V	
TASF-AFC1T1		5°C-45°C	440V-480V	

## Option:

**Low Ambient Temperature:** The low ambient option adds unit controls and deploy to allow start and operation when the unit works with minimum ambient temperatures at -10°C.

**Low Temperature Brine:** ethylene glycol and propylene glycol (maximum concentration 45%) can be chosen as optional and leaving water temperature shall not less than -5.6°C.

**Anti-corrosion:** Blygold coating or electrophoretic coating can be chosen as optional.

**Vibration Isolators:** Vibration Isolators provide isolation between chiller and structure to help eliminate vibration transmission.

# Features

## Energy-efficient

### High-efficiency Compressor

The high-efficiency semi-hermetic twin-screw compressor, which is specially designed for the R134a refrigerant, can realize stepless regulation for energy through its slide valve. The energy regulation range of a single-compressor unit is from 25% to 100%, and regulation range of a dual-compressor unit is from 12.5% to 100%, which can well avoid the problems faced by ordinary units such as frequent start and stop, large fluctuations in water temperature and especially, excessive temperature and humidity control in technological places, thus minimizing the operation cost.



### High-efficiency Heat Exchanger

As for the high-efficiency flooded heat exchanger, the complex tooth-type structure on the external surface of the heat exchange tube facilitates nuclear boiling, thus largely improving the heat transmission outside of the tube; The spiral tooth-type structure on the internal surface helps increase the disturbance of refrigerating medium when it is flowing in the tube, which greatly increases the heat exchange efficiency in the tube.

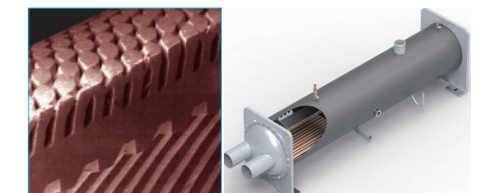

### Two-stage High-efficiency Oil Separator + Unique Oil Return Technology

The external level-2 oil separator, which is a high-efficiency horizontal oil separator of independent research and development, has a built-in high-strength stainless steel filter screen. Through collision, filtering and gravity, the oil separator can realize an oil separation efficiency of over 99.9%, which greatly reduces oil residual in the heat exchanger and increases the operating efficiency of the entire unit.

The patented continuous oil return technology of TICA - oil injected by oil - ensures the safety of oil supply for the compressor as it can take the residual 0.1% refrigeration oil in the evaporator back to the compressor without increasing the power consumption of the compressor.

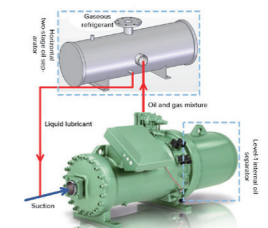

### Electronic Expansion Valve

The unit is equipped with an electronic expansion valve that has a high control accuracy and fast response. Under full load and partial load, the electronic expansion valve can always have an excellent performance that helps greatly increase the energy conservation performance and stability of the unit as well as lower the operation cost.



### Economizer Circulation

Each unit of the TASF series is designed with an economizer, which dramatically improves the performance and reliability of the unit.

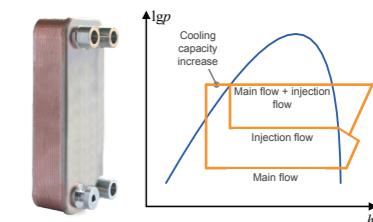

## Comfort and Low Noise

### Precise Control for Water Temperature

The high-precision stepless regulation to the energy regulation slide valve of the compressor realizes high consistency between the actual load and the target load of the compressor and ensures a perfect match between the output capacity of the unit and the demand load of the building system. "Output on demand" of energy ensures temperature stability of outlet water, and the control precision of water temperature can reach  $\pm 0.3^{\circ}\text{C}$ .

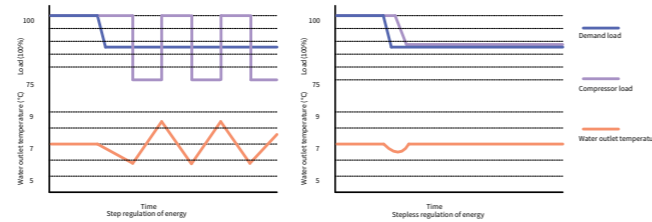

### Low Noise

The unit, which adopts a large airflow and low-noise inner rotor axial flow fan of a well-known brand and is equipped with a long air duct for air diversion, can effectively reduce the noise caused by airflow. Before delivery, the fan has undergone strict tests on static and dynamic equilibrium to ensure stable and low-noise operation. The compressor feet are equipped with rubber shock pads which cannot only reduce unit vibration transmission but also can significantly decrease unit noise; A noise enclosure and spring shock absorber are also optional for the unit to further reduce noise.



### Environmentally Friendly

The environmentally-friendly refrigerant HFC-R134a is used, which does not contain chlorine atoms, is harmless to the atmospheric ozone layer, and has no ban period in the Montreal Agreement; Higher efficiency, fewer power consumption and reduced CO2 emissions; As one of the first enterprises in China's industrial and commercial refrigeration and air-conditioning industry that signed the HCHC Phase-Out Project with the Ministry of Environmental Protection, TICA has always been dedicated to the development of green and environmentally friendly products.



## Reliable Operation

### Multiple Protection Functions

The unit provides multiple safety protection functions to conduct all-round comprehensive monitoring for the unit and the system. In case of any abnormality occurring to the application environment or the system, the functions can protect the unit from damage in a timely manner. The unit has three levels of passwords in order to prevent operations by unauthorized personnel and to ensure safe operation of the unit.



- |   |   |
|---|---|
| Protection of power supply default phase, reverse phase, and unbalanced phase | Protection of too low evaporation pressure              |
| Compressor oil level protection   | Protection of air suction/discharge pressure difference |
| Compressor motor overheat protection  | Disconnection protection                                |
| Compressor motor overload protection  | Protection of too high discharge temperature            |
| Fan overload protection   | Protection of too high water temperature                |
| Compressor start failure protection   | Excessive temperature difference protection             |
| Compressor reverse rotation protection  |   |
| Protection of too high condensation pressure                                  |   |

### Long-term Simulation Experiment

TICA has built a large 350RT air cooling unit performance laboratory. The performance, reliability and structure of the unit are verified and optimized by long-term simulation tests under various changing conditions and extreme conditions, as well as transportation experiment on actual tertiary roads in order to ensure the quality and performance of the unit.



## Intelligent Control

### Intelligent Control System

- The industrial-level microcomputer controller and the LCD screen constitute the control center of the unit. In addition, TICA's auto control technology of independent development features the world's most advanced control technology and enables powerful control functions.
- With a cutting-edge intelligent control program and an advanced capacity regulation system, the compressor can realize stepless regulation at a load range of 25% - 100%. The unit load and the load at the user side which are highly matched ensures precise control of water temperature by the unit under all working conditions, and the temperature control precision can reach  $\pm 0.3^{\circ}\text{C}$ .
- The application of graded control for the unit fan effectively reduces the power consumption of the unit in the transitional ambient temperature;
- The advanced pre-control function makes it possible for the operator to take relevant remedy measures in a timely manner before any failure occurs to avoid frequent shutdown of the unit;
- The unit supports the compiling of weekly operating schedules to implement comprehensive automatic start and stop control of the unit, which truly implements unattended and automatic operation.

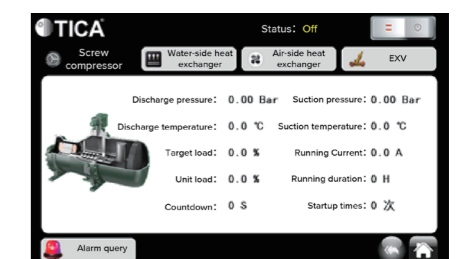

# Specifications

## T1 Condition.(380V 3N~50Hz)

Model TASF-AAC1T1		095.1	120.1	140.1	155.1	180.1	205.1	225.1	240.1	140.2	160.2	180.2	205.2	
Nominal cooling capacity	kW	336	425	495	556	645	725	791	820	503	568	644	732	
	kcal/h	288960	365500	425700	478160	554700	623500	680260	705200	432580	488480	553840	629520	
Cooling power input	kW	99.5	133.0	147.0	166.0	190.8	215.8	244.5	255.4	154.8	177.5	200.6	224.6	
EER	kW/kW	3.38	3.20	3.37	3.35	3.38	3.36	3.24	3.21	3.25	3.20	3.21	3.26	
Cooling rated current	A	182	229	264	294	340	378	430	447	290	327	362	399	
Maximum startup current	A	358	488	615	683	845	845	965	965	596	601	671	671	
Maximum operating current	A	254	303	353	388	439	480	563	504	435	486	562	562	
Refrigerant	Type	R134a												
	Refrigerant circuit number	1						2						
Compressor	Type	Semi-hermetic screw compressor												
	Energy regulation range	25%-100% stepless regulation						12.5%-100% stepless regulation						
	Startup Type	Y-△												
Fan	Air flow	m <sup>3</sup> /h	147000	147000	196000	196000	245000	245000	294000	294000	196000	196000	294000	294000
	Quantity	Set	6	6	8	8	10	10	12	12	8	8	12	12
	Fan motor	kW	13.8	13.8	18.4	18.4	23.0	23.0	27.6	27.6	18.4	18.4	27.6	27.6
	Current	A	31.8	31.8	42.4	42.4	53.0	53.0	63.6	63.6	42.4	42.4	63.6	63.6
Water side heat exchanger	Type	Highly Efficient Flooded Shell-and-Tube												
	Water flow	m <sup>3</sup> /h	58	73	85	96	111	125	136	141	87	98	111	126
	Water pipe diameter	DN(mm)	150	150	150	150	150	150	200	150	150	150	150	
	Water pressure drop	kPa	62	68	71	68	67	71	72	67	62	66	68	71
Design Pressure	MPa	1.0												
Dimensions	Length	mm	3600	3600	4790	4790	5990	5990	7180	7180	4790	4790	7180	7180
	Width	mm	2250											
	High	mm	2460											
Weight of unit	Transportation	kg	3660	4150	4600	4700	5530	5650	6200	6380	5420	5560	7320	7452
	Operation	kg	3710	4210	4670	4780	5620	5750	6310	6500	5490	5640	7430	7572

★Notes:

- Nominal cooling condition: chilled water inlet/outlet temperature is 12°C/7°C, ambient dry bulb temperature is 35°C.
- Allowable voltage fluctuation range is 360V~400V.
- The above parameters may change because of product improvement. Therefore, it shall be subject to the parameters on the product nameplate and the actual product.

## T1 Condition.(380V 3N~50Hz)

Model TASF-AAC1T1		240.2	260.2	280.2	310.2	340.2	360.2	375.2	410.2	445.2	475.2	
Nominal cooling capacity	kW	850	894	989	1112	1184	1291	1316	1450	1564	1682	
	kcal/h	731000	768840	850540	956320	1018240	1110260	1131760	1247000	1345040	1446520	
Cooling power input	kW	266.0	268.8	294.1	335.4	348.8	380.8	391.7	429.4	484.2	523.3	
EER	kW/kW	3.20	3.33	3.36	3.32	3.39	3.39	3.36	3.38	3.23	3.21	
Cooling rated current	A	459	491	527	593	629	679	694	753	851	912	
Maximum startup current	A	791	968	968	1071	1284	1284	1325	1325	1517	1458	
Maximum operating current	A	606	707	707	777	878	878	960	960	1104	986	
Refrigerant	Type	R134a										
	Refrigerant circuit number	2										
Compressor	Type	Semi-hermetic screw compressor										
	Energy regulation range	12.5%-100% stepless regulation										
	Startup Type	Y-△										
Fan	Air flow	m <sup>3</sup> /h	294000	392000	392000	392000	490000	490000	490000	490000	450000	450000
	Quantity	Set	12	16	16	16	20	20	20	20	20	20
	Fan motor	kW	27.6	36.8	36.8	36.8	46.0	46.0	46.0	46.0	46.0	46
	Current	A	63.6	84.8	84.8	84.8	106.0	106.0	106.0	106.0	106.0	106.0
Water side heat exchanger	Type	Highly Efficient Flooded Shell-and-Tube										
	Water flow	m <sup>3</sup> /h	146	154	170	191	204	222	226	249	269	289
	Water pipe diameter	DN(mm)	200	200	200	200	200	200	200	200	200	200
	Water pressure drop	kPa	71	68	71	69	69	68	71	72	72	70
Design Pressure	MPa	1.0										
Dimensions	Length	mm	7180	9570	9570	9570	11970	11970	11970	11970	11970	11970
	Width	mm	2250									
	High	mm	2460	2520								
Weight of unit	Transportation	kg	8300	9080	9200	9400	10910	11060	11120	11300	11850	11950
	Operation	kg	8430	9220	9350	9560	11080	11240	11310	11500	12060	12170

★Notes:

- Nominal cooling condition: chilled water inlet/outlet temperature is 12°C/7°C, ambient dry bulb temperature is 35°C.
- Allowable voltage fluctuation range is 360V~400V.
- The above parameters may change because of product improvement. Therefore, it shall be subject to the parameters on the product nameplate and the actual product.

### T1 Condition.(400V 3N~50Hz)

Model TASF-AJC1T1		095.1	120.1	140.1	155.1	180.1	205.1	225.1	240.1	140.2	160.2	180.2	205.2	
Nominal cooling capacity	kW	336	425	495	556	645	725	791	820	503	568	644	732	
	kcal/h	288960	365500	425700	478160	554700	623500	680260	705200	432580	488480	553840	629520	
Cooling power input	kW	99.5	133.0	147.0	166.0	190.8	215.8	244.5	255.4	154.8	177.5	200.6	224.6	
EER	kW/kW	3.38	3.20	3.37	3.35	3.38	3.36	3.24	3.21	3.25	3.20	3.21	3.26	
Cooling rated current	A	173	218	250	279	323	359	409	425	276	311	344	379	
Maximum startup current	A	340	464	584	649	803	803	917	917	566	571	637	637	
Maximum operating current	A	241	288	336	369	417	456	534	478	413	462	534	534	
Refrigerant	Type	R134a												
	Refrigerant circuit number	1						2						
Compressor	Type	Semi-hermetic screw compressor												
	Energy regulation range	25%-100% stepless regulation						12.5%-100% stepless regulation						
	Startup Type	Y-Δ												
Fan	Air flow	m <sup>3</sup> /h	147000	147000	196000	196000	245000	245000	294000	294000	196000	196000	294000	294000
	Quantity	Set	6	6	8	8	10	10	12	12	8	8	12	12
	Fan motor	kW	13.8	13.8	18.4	18.4	23.0	23.0	27.6	27.6	18.4	18.4	27.6	27.6
	Current	A	30.2	30.2	40.3	40.3	50.4	50.4	60.5	60.5	40.3	40.3	60.5	60.5
Water side heat exchanger	Type	Highly Efficient Flooded Shell-and-Tube												
	Water flow	m <sup>3</sup> /h	58	73	85	96	111	125	136	141	87	98	111	126
	Water pipe diameter	DN(mm)	150	150	150	150	150	150	150	200	150	150	150	150
	Water pressure drop	kPa	62	68	71	68	67	71	72	67	62	66	68	71
Design Pressure	MPa	1.0												
Dimensions	Length	mm	3600	3600	4790	4790	5990	5990	7180	7180	4790	4790	7180	7180
	Width	mm	2250											
	High	mm	2460											
Weight of unit	Transportation	kg	3660	4150	4600	4700	5530	5650	6200	6380	5420	5560	7320	7452
	Operation	kg	3710	4210	4670	4780	5620	5750	6310	6500	5490	5640	7430	7572

★Notes:

- Nominal cooling condition: chilled water inlet/outlet temperature is 12°C/7°C, ambient dry bulb temperature is 35°C.
- Allowable voltage fluctuation range is 380V~420V.
- The above parameters may change because of product improvement. Therefore, it shall be subject to the parameters on the product nameplate and the actual product.

### T1 Condition.(400V 3N~50Hz)

Model TASF-AJC1T1		240.2	260.2	280.2	310.2	340.2	360.2	375.2	410.2	445.2	475.2	
Nominal cooling capacity	kW	850	894	989	1112	1184	1291	1316	1450	1564	1682	
	kcal/h	731000	768840	850540	956320	1018240	1110260	1131760	1247000	1345040	1446520	
Cooling power input	kW	266.0	268.8	294.1	335.4	348.8	380.8	391.7	429.4	484.2	523.3	
EER	kW/kW	3.20	3.33	3.36	3.32	3.39	3.39	3.36	3.38	3.23	3.21	
Cooling rated current	A	436	466	501	563	598	645	659	715	808	866	
Maximum startup current	A	751	920	920	1018	1220	1220	1259	1259	1441	1385	
Maximum operating current	A	575	671	671	738	834	834	912	912	1049	937	
Refrigerant	Type	R134a										
	Refrigerant circuit number	2										
Compressor	Type	Semi-hermetic screw compressor										
	Energy regulation range	12.5%-100% stepless regulation										
	Startup Type	Y-Δ										
Fan	Air flow	m <sup>3</sup> /h	294000	392000	392000	392000	490000	490000	490000	490000	450000	450000
	Quantity	Set	12	16	16	16	20	20	20	20	20	20
	Fan motor	kW	27.6	36.8	36.8	36.8	46.0	46.0	46.0	46.0	46.0	46.0
	Current	A	60.5	80.6	80.6	80.6	100.8	100.8	100.8	100.8	100.8	100.8
Water side heat exchanger	Type	Highly Efficient Flooded Shell-and-Tube										
	Water flow	m <sup>3</sup> /h	146	154	170	191	204	222	226	249	269	289
	Water pipe diameter	DN(mm)	200	200	200	200	200	200	200	200	200	200
	Water pressure drop	kPa	71	68	71	69	69	68	71	72	72	70
Design Pressure	MPa	1.0										
Dimensions	Length	mm	7180	9570	9570	9570	11970	11970	11970	11970	11970	11970
	Width	mm	2250									
	High	mm	2460	2520								
Weight of unit	Transportation	kg	8300	9080	9200	9400	10910	11060	11120	11300	11850	11950
	Operation	kg	8430	9220	9350	9560	11080	11240	11310	11500	12060	12170

★Notes:

- Nominal cooling condition: chilled water inlet/outlet temperature is 12°C/7°C, ambient dry bulb temperature is 35°C.
- Allowable voltage fluctuation range is 380V~420V.
- The above parameters may change because of product improvement. Therefore, it shall be subject to the parameters on the product nameplate and the actual product.

### T1 Condition.(460V 3N~60Hz)

Model TASF-AFC1T1		100.1	120.1	145.1	165.1	190.1	215.1	245.1	265.1	285.1	150.2	165.2	200.2	
Nominal cooling capacity	kW	355	430	513	579	667	755	867	940	1011	528	589	709	
	kcal/h	305300	369800	441180	497940	573620	649300	745620	808400	869460	454080	506540	609740	
Cooling power input	kW	107.4	133.9	157.6	178.3	203.2	231.5	256.7	292.2	311.5	164.6	183.8	212.6	
Cooling rated current	A	157	188	217	253	286	327	358	408	433	242	272	312	
EER	kW/kW	3.31	3.21	3.26	3.25	3.28	3.26	3.38	3.22	3.25	3.21	3.20	3.33	
Maximum startup current	A	314	371	465	586	650	805	805	917	917	485	522	533	
Maximum operating current	A	219	268	296	335	378	416	466	545	490	370	417	438	
Power supply		460V~3N~60Hz												
Refrigerant	Type	R134a												
	Refrigerant circuit number	1						2						
Compressor	Type	Semi-hermetic screw compressor												
	Energy regulation range	25%-100% stepless regulation									12.5%-100% stepless regulation			
	Startup Type	Y-△												
Fan	Air flow	m <sup>3</sup> /h	147000	147000	196000	196000	245000	245000	294000	343000	343000	196000	196000	294000
	Quantity	Set	6	6	8	8	10	10	12	14	14	8	8	12
	Fan motor	kW	13.2	13.2	17.6	17.6	22	22	26.4	30.8	30.8	17.6	17.6	26.4
	Current	A	31.8	31.8	42.4	42.4	53	53	63.6	74.2	74.2	42.4	42.4	63.6
Water side heat exchanger	Type	Highly Efficient Flooded Shell-and-Tube												
	Water flow	m <sup>3</sup> /h	61	74	88	100	115	130	149	162	174	91	101	122
	Water pipe diameter	DN(mm)	150	150	150	150	150	150	200	200	200	150	150	150
	Water pressure drop	kPa	69	70	76	74	72	77	74	73	71	68	71	68
	Design Pressure	MPa	1.0											
Dimensions	Length	mm	3600	3600	4790	4790	5990	5990	7180	8380	8380	4790	4790	7180
	Width	mm	2250											
	High	mm	2460											
Weight of unit	Transportation	kg	3630	4120	4570	4670	5520	5610	6140	7020	7050	5240	5340	7260
	Operation	kg	3680	4170	4630	4730	5610	5700	6240	7140	7195	5320	5420	7360

★Notes:

- Nominal cooling condition: chilled water inlet/outlet temperature is 12°C/7°C, ambient dry bulb temperature is 35°C.
- Allowable voltage fluctuation range is 440V~480V.
- The above parameters may change because of product improvement. Therefore, it shall be subject to the parameters on the product nameplate and the actual product.

### T1 Condition.(460V 3N~60Hz)

Model TASF-AFC1T1		225.2	240.2	260.2	290.2	300.2	330.2	345.2	380.2	395.2	430.2	445.2	485.2	
Nominal cooling capacity	kW	795	860	922	1026	1052	1159	1210	1335	1393	1511	1566	1715	
	kcal/h	683700	739600	792920	882360	904720	996740	1040600	1148100	1197980	1299460	1346760	1474900	
Cooling power input	kW	241.3	267.7	281.8	315.2	328.5	356.6	369.1	402.2	423.3	458.3	469.6	510.8	
Cooling rated current	A	350	376	392	434	474	506	527	566	603	647	660	711	
EER	kW/kW	3.29	3.21	3.27	3.26	3.20	3.25	3.28	3.32	3.29	3.30	3.33	3.36	
Maximum startup current	A	582	639	761	761	921	921	1028	1028	1221	1221	1260	1260	
Maximum operating current	A	482	536	593	593	671	671	756	756	832	832	910	910	
Power supply		460V~3N~60Hz												
Refrigerant	Type	R134a												
	Refrigerant circuit number	2												
Compressor	Type	Semi-hermetic screw compressor												
	Energy regulation range	12.5%-100% stepless regulation												
	Startup Type	Y-△												
Fan	Air flow	m <sup>3</sup> /h	294000	294000	392000	392000	392000	392000	490000	490000	490000	490000	450000	450000
	Quantity	Set	12	12	16	16	16	16	20	20	20	20	20	20
	Fan motor	kW	26.4	26.4	35.2	35.2	35.2	35.2	44	44	44	44	44	44
	Current	A	63.6	63.6	84.8	84.8	84.8	84.8	106	106	106	106	106	106
Water side heat exchanger	Type	Highly Efficient Flooded Shell-and-Tube												
	Water flow	m <sup>3</sup> /h	137	148	159	177	181	199	208	230	240	260	269	295
	Water pipe diameter	DN(mm)	150	200	200	200	200	200	200	200	200	200	200	200
	Water pressure drop	kPa	71	73	72	68	71	67	72	73	72	72	72	73
	Design Pressure	MPa	1.0											
Dimensions	Length	mm	7180	7180	9570	9570	9570	9570	11970	11970	11970	11970	11970	
	Width	mm	2250											
	High	mm	2460			2520								
Weight of unit	Transportation	kg	8170	8240	8980	9140	9260	9340	10850	11040	11080	11280	11630	12040
	Operation	kg	8280	8360	9090	9260	9390	9480	11000	11200	11250	11460	11820	12240

★Notes:

- Nominal cooling condition: chilled water inlet/outlet temperature is 12°C/7°C, ambient dry bulb temperature is 35°C.
- Allowable voltage fluctuation range is 440V~480V.
- The above parameters may change because of product improvement. Therefore, it shall be subject to the parameters on the product nameplate and the actual product.

### T3 Condition.(380V 3N~50Hz)

Model TASF-AAC1T3		095.1	120.1	140.1	155.1	180.1	205.1	225.1	140.2	160.2	180.2	205.2	
Nominal cooling capacity	kW	336	425	495	556	645	725	791	503	568	644	733	
	kcal/h	288960	365500	425700	478160	554700	623500	680260	432580	488480	553840	630380	
Cooling power input	kW	99.5	133.0	147.0	166.0	190.8	215.8	244.5	154.8	177.5	200.6	224.7	
Cooling rated current	A	182	229	264	294	340	378	430	290	327	362	399	
EER	kW/kW	3.38	3.20	3.37	3.35	3.38	3.36	3.24	3.25	3.20	3.21	3.26	
Nominal cooling capacity*	kW	298	376	438	493	571	642	701	428	483	548	648	
	kcal/h	256280	323360	376680	423980	491060	552120	602860	368080	415380	471280	557280	
Cooling power input*	kW	123.9	165.6	183.1	206.7	237.6	268.7	304.5	189.2	217.0	245.2	279.7	
Cooling rated current*	A	222	279	321	357	414	461	524	348	392	433	486	
Maximum startup current	A	358	488	615	683	845	845	965	626	637	695	695	
Maximum operating current	A	259	379	431	483	526	526	660	496	558	610	610	
Power supply		380V 3N ~ 50Hz											
Refrigerant	Type	R134a											
	Refrigerant circuit number	1					2						
Compressor	Type	Semi-hermetic screw compressor											
	Energy regulation range	25%-100% stepless regulation						12.5%-100% stepless regulation					
	Startup Type	Y-△											
Fan	Air flow	m <sup>3</sup> /h	147000	147000	196000	196000	245000	245000	294000	196000	196000	294000	294000
	Quantity	Set	6	6	8	8	10	10	12	8	8	12	12
	Fan motor	kW	13.8	13.8	18.4	18.4	23.0	23.0	27.6	18.4	18.4	27.6	27.6
	Current	A	31.8	31.8	42.4	42.4	53.0	53.0	63.6	42.4	42.4	63.6	63.6
Water side heat exchanger	Type	Highly Efficient Flooded Shell-and-Tube											
	Water flow	m <sup>3</sup> /h	58	73	85	96	111	125	136	87	98	111	126
	Water pipe diameter	DN(mm)	150	150	150	150	150	150	150	150	150	150	150
	Water pressure drop	kPa	62	68	71	68	67	71	72	62	66	68	71
	Design Pressure	MPa	1.0										
Dimensions	Length	mm	3600	3600	4790	4790	5990	5990	7180	4790	4790	7180	7180
	Width	mm	2250										
	High	mm	2460										
Weight of unit	Transportation	kg	3660	4150	4600	4700	5530	5650	6200	5420	5560	7320	7452
	Operation	kg	3710	4210	4670	4780	5620	5750	6310	5490	5640	7430	7572

★Notes:

- Nominal cooling condition: chilled water outlet temperature is 12°C/7°C, ambient dry bulb temperature is 35°C.
- \*: The parameters in condition of: chilled water outlet temperature is 7°C, ambient dry bulb temperature is 46°C.
- Allowable voltage fluctuation range is 360V~400V.
- The above parameters may change because of product improvement. Therefore, it shall be subject to the parameters on the product nameplate and the actual product.

### T3 Condition.(380V 3N~50Hz)

Model TASF-AAC1T3		240.2	260.2	280.2	310.2	340.2	360.2	375.2	410.2	445.2	
Nominal cooling capacity	kW	850	894	989	1112	1184	1291	1316	1450	1564	
	kcal/h	731000	768840	850540	956320	1018240	1110260	1131760	1247000	1345040	
Cooling power input	kW	266.0	268.8	294.1	335.4	348.8	380.8	391.7	429.4	484.2	
Cooling rated current	A	459	491	527	593	629	679	694	753	851	
EER	kW/kW	3.20	3.33	3.36	3.32	3.39	3.39	3.36	3.38	3.23	
Nominal cooling capacity*	kW	753	760	876	985	1007	1144	1119	1284	1385	
	kcal/h	647580	653600	753360	847100	866020	983840	962340	1104240	1191100	
Cooling power input*	kW	331.3	328.6	366.2	417.7	426.3	474.2	478.8	534.7	603.0	
Cooling rated current*	A	559	587	642	722	753	826	830	917	1036	
Maximum startup current	A	867	1046	1046	1166	1371	1371	1371	1371	1614	
Maximum operating current	A	758	863	863	967	1052	1052	1052	1052	1298	
Power supply		380V 3N ~ 50Hz									
Refrigerant	Type	R134a									
	Refrigerant circuit number	2									
Compressor	Type	Semi-hermetic screw compressor									
	Energy regulation range	12.5%-100% stepless regulation									
	Startup Type	Y-△									
Fan	Air flow	m <sup>3</sup> /h	294000	392000	392000	392000	490000	490000	490000	490000	450000
	Quantity	Set	12	16	16	16	20	20	20	20	20
	Fan motor	kW	27.6	36.8	36.8	36.8	46.0	46.0	46.0	46.0	46.0
	Current	A	63.6	84.8	84.8	84.8	106.0	106.0	106.0	106.0	106.0
Water side heat exchanger	Type	Highly Efficient Flooded Shell-and-Tube									
	Water flow	m <sup>3</sup> /h	146	154	170	191	204	222	226	249	269
	Water pipe diameter	DN(mm)	200	200	200	200	200	200	200	200	200
	Water pressure drop	kPa	71	68	71	69	69	68	71	72	72
	Design Pressure	MPa	1.0								
Dimensions	Length	mm	7180	9570	9570	9570	11970	11970	11970	11970	11970
	Width	mm	2250								
	High	mm	2460	2520							
Weight of unit	Transportation	kg	8300	9080	9200	9400	10910	11060	11120	11300	11850
	Operation	kg	8430	9220	9350	9560	11080	11240	11310	11500	12060

★Notes:

- Nominal cooling condition: chilled water inlet/outlet temperature is 12°C/7°C, ambient dry bulb temperature is 35°C.
- \*: The parameters in condition of: chilled water outlet temperature is 7°C, ambient dry bulb temperature is 46°C.
- Allowable voltage fluctuation range is 360V~400V.
- The above parameters may change because of product improvement. Therefore, it shall be subject to the parameters on the product nameplate and the actual product.



# Water Pressure Drop Curve

## Water Pressure Drop Curve-Single Compressor(50Hz)

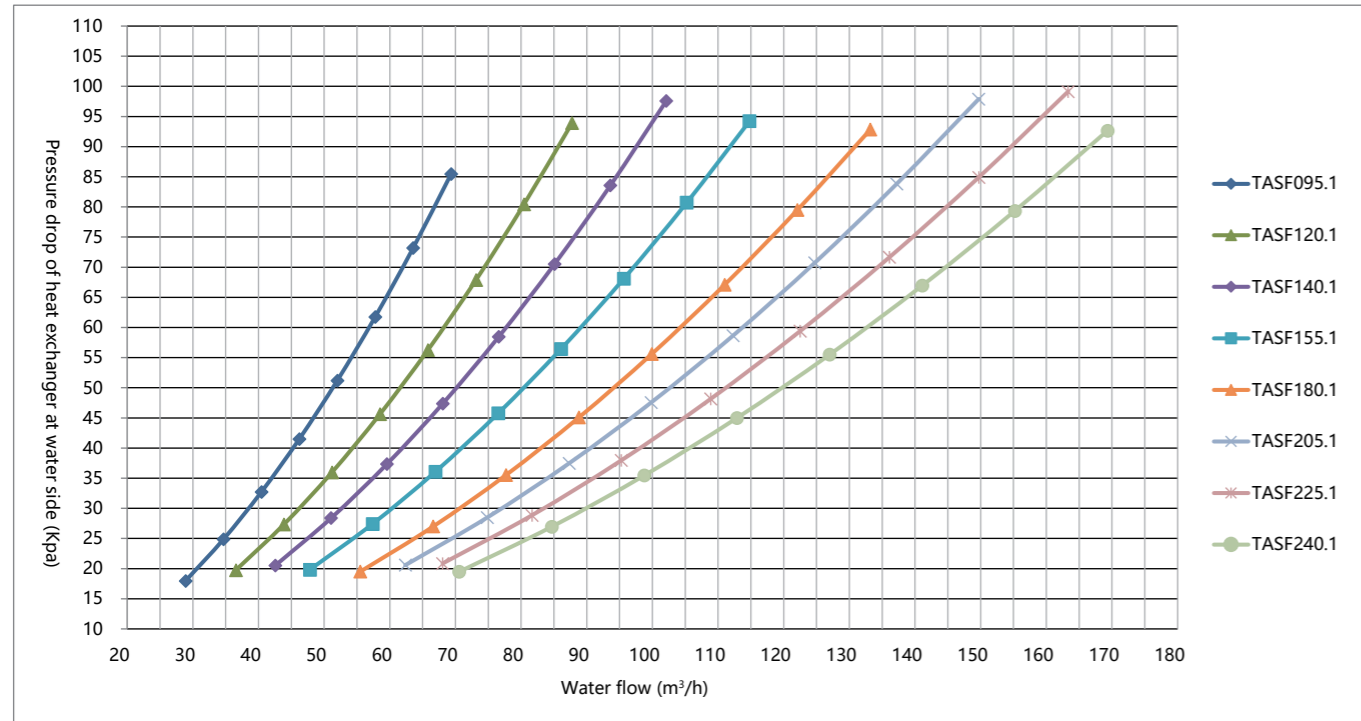

## Water Pressure Drop Curve-Single Compressor(60Hz)

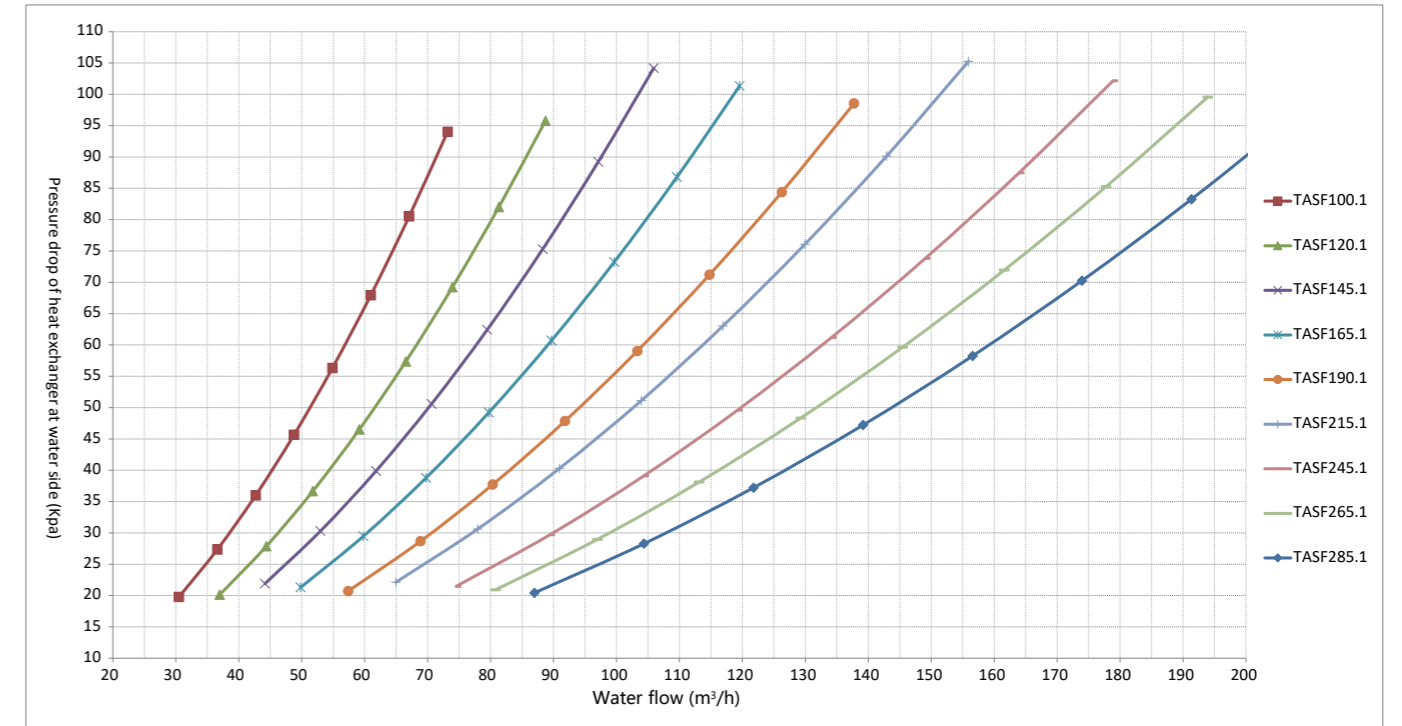

## Water Pressure Drop Curve-Dual Compressors(50Hz)

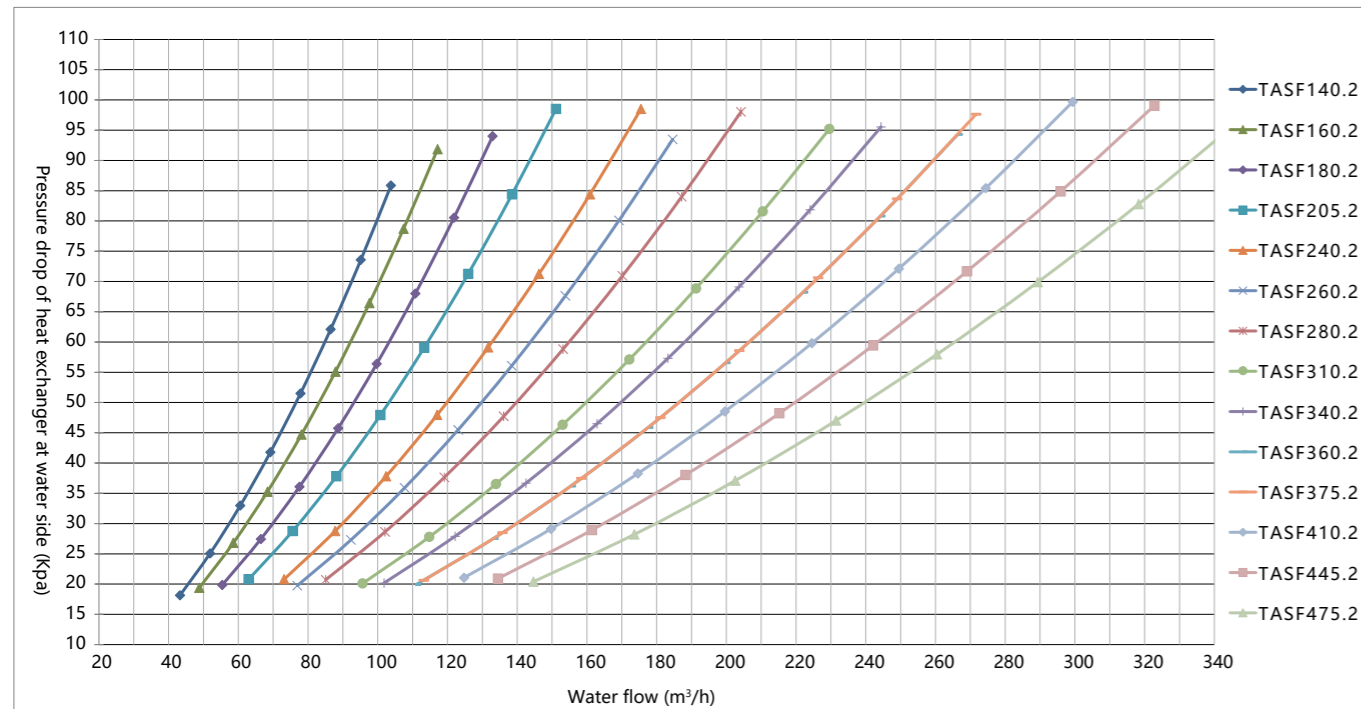

## Water Pressure Drop Curve-Dual Compressors(60Hz)

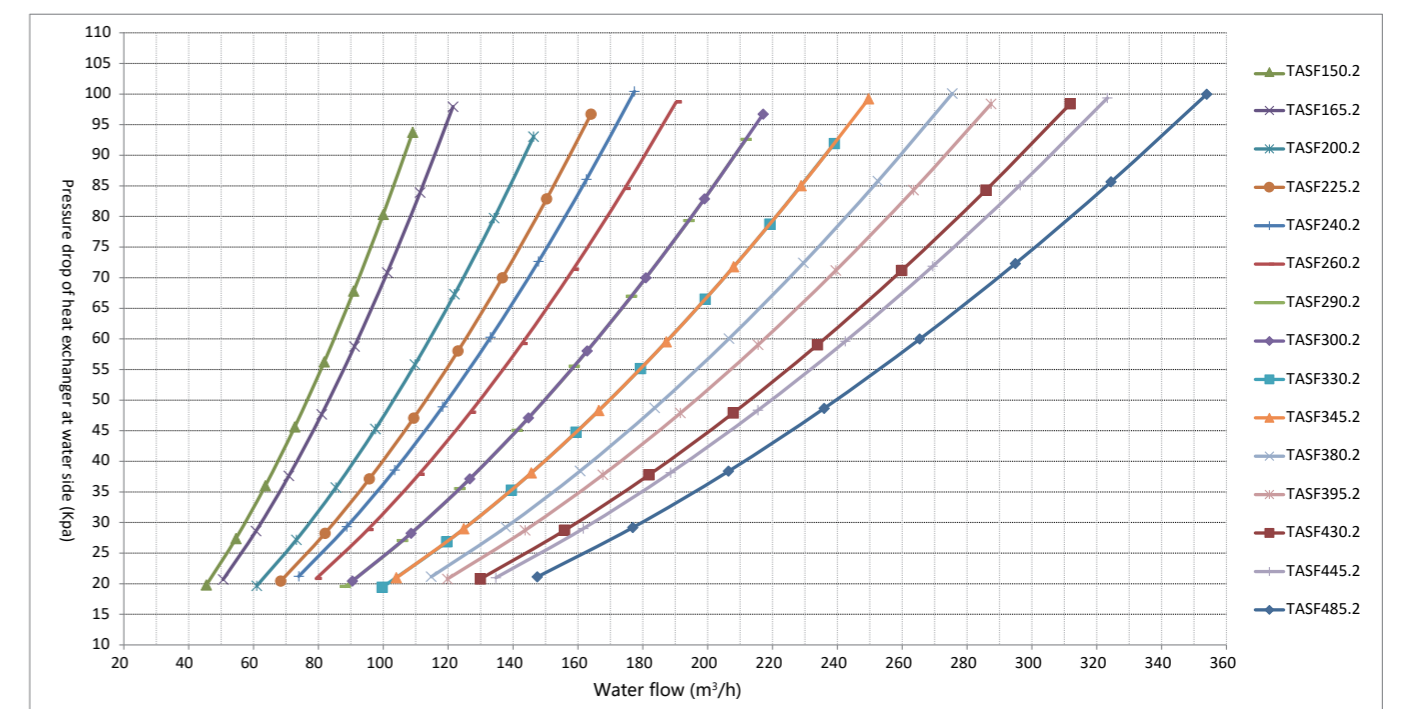

# TASF Dimensions Data

095.1/100.1/120.1

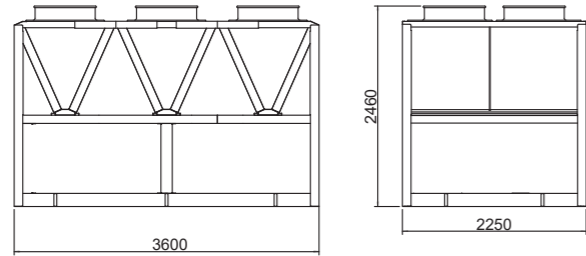

265.1/285.1

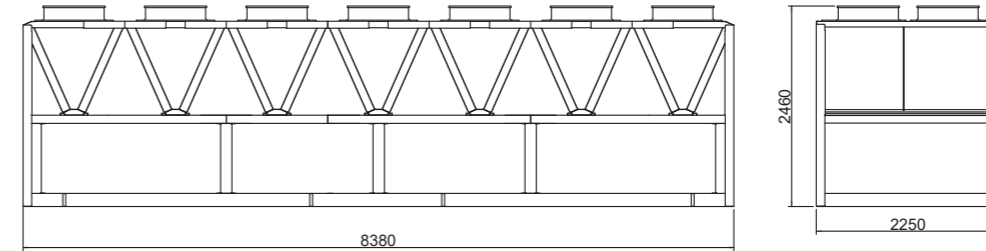

140.1/145.1/155.1/165.1

140.2/150.2/160.2/165.2

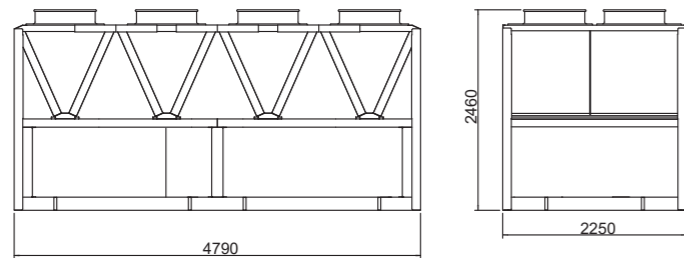

260.2/280.2/290.2/300.2/310.2/330.2

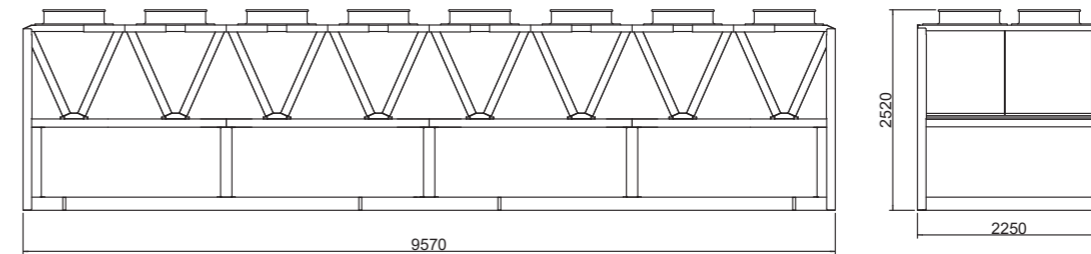

180.1/190.1/205.1/215.1

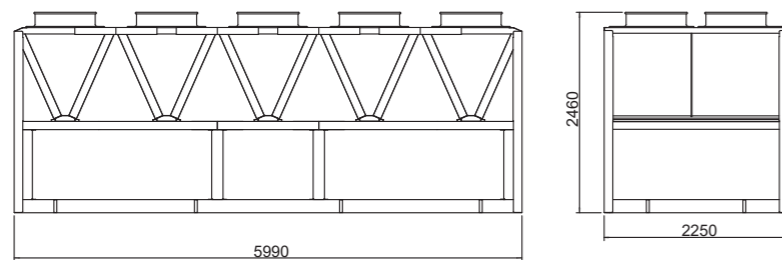

340.2/345.2/360.2/375.2/380.2/395.2/410.2/430.2/445.2/475.2/485.2

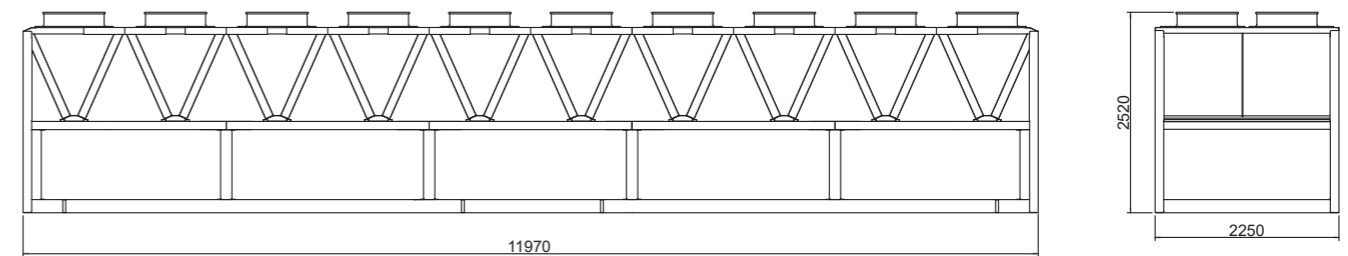

225.1/240.1/245.1

180.2/200.2/205.2/225.2/240.2

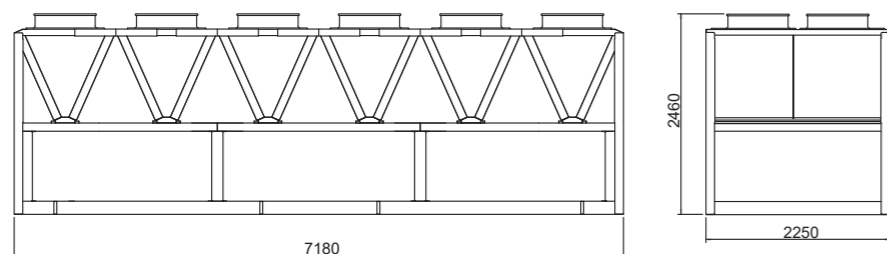

# Unit Installation Diagrams

## Diagram for Installation Space of Unit

Layout requirements for corners or depressions

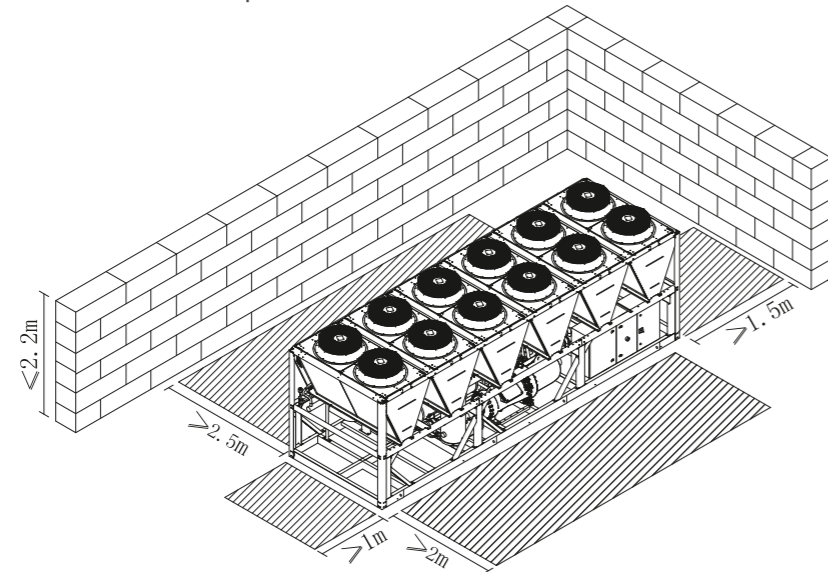

★ Notes

1. The unit must be installed in a place with good ventilation and heat transmission. To prevent inverse flow of condenser air, it is recommended to reserve side spacing as shown above; under such conditions, there should not be any obstacles above the unit.
2. In case of any structure above the unit, a space height of at least 3 meters shall be reserved between the structure and the unit so as to ensure free airflow for the unit;
3. Since the re-circulating hot air seriously affects the energy efficiency ratio of the unit or even causes the condensing pressure to be too high or the fan motor to fail, please make sure to meet the requirement for installation space mentioned above.

## Diagram for Lifting and Placement of Unit

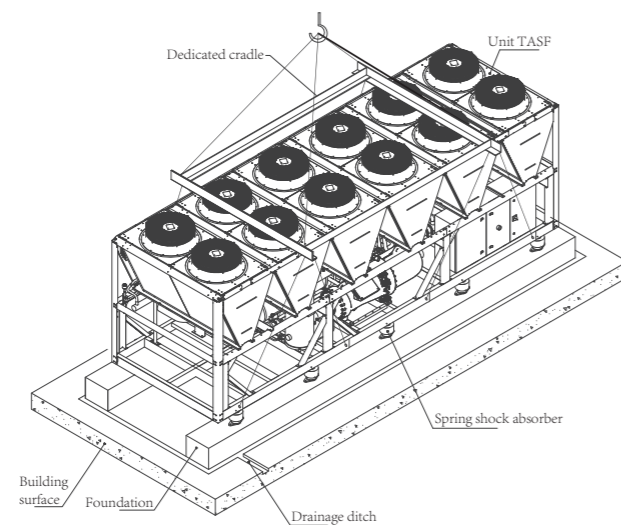

★ Notes

1. Lift the unit according to the diagram. Make sure to use special lifting equipment such as cradle to protect the unit;
2. In case of any scratches occurring during the lifting process, it is recommended to treat the damaged parts.

# Foundation Diagrams

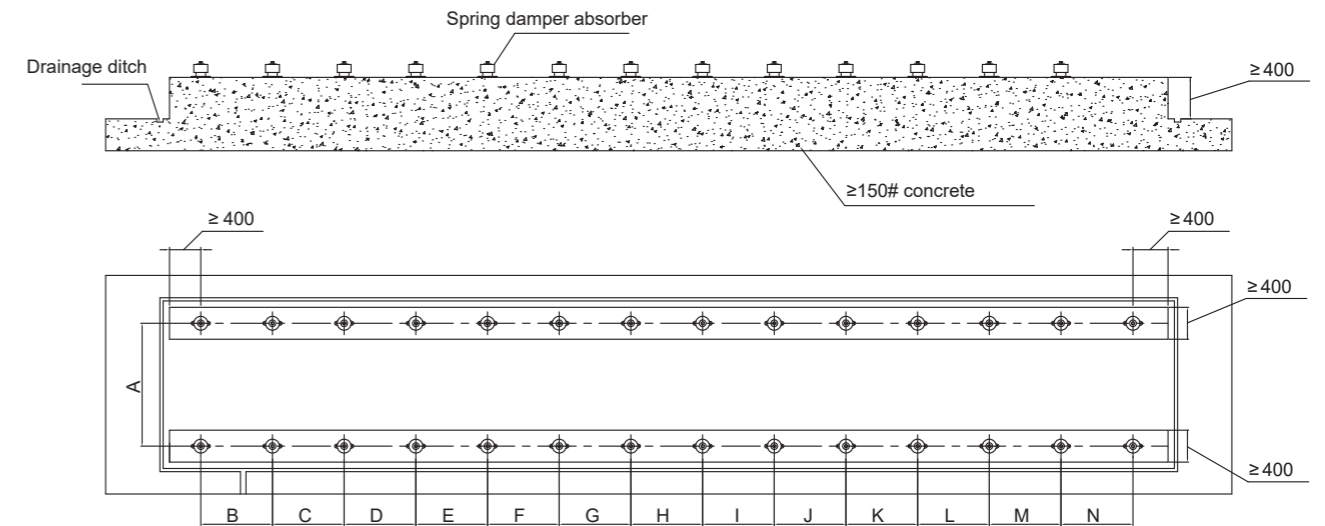

Model	Code (mm)														Spring damper absorber	
	A	B	C	D	E	F	G	H	I	J	K	L	M	N	Model	Quantity
TASF095.1AA/JC1T1 TASF095.1AAC1T3 TASF100.1AFC1T1	2170	1392	1392	-	-	-	-	-	-	-	-	-	-	-	MHD-850	6
TASF120.1AA/JC1T1 TASF120.1AAC1T3 TASF120.1AFC1T1	2170	1392	1392	-	-	-	-	-	-	-	-	-	-	-	MHD-1050	6
TASF140.1AA/JC1T1 TASF140.1AAC1T3 TASF145.1AFC1T1	2170	1390	1390	1390	-	-	-	-	-	-	-	-	-	-	MHD-810	8
TASF155.1AA/JC1T1 TASF155.1AAC1T3 TASF165.1AFC1T1	2170	1390	1390	1390	-	-	-	-	-	-	-	-	-	-	MHD-850	8
TASF180.1AA/JC1T1 TASF205.1AA/JC1T1 TASF180.1AAC1T3 TASF205.1AAC1T3 TASF190.1AFC1T1 TASF215.1AFC1T1	2170	1340	1340	1340	1340	-	-	-	-	-	-	-	-	-	MHD-810	10

★ Notes

1. Foundation levelness  $\le 0.1\%$ ;
2. The bearing capacity of foundation  $\ge 1.5$  times of the operating weight of unit;
3. Drainage ditches must be provided around the foundation to prevent accumulation of water;
4. Shock absorbers must be installed between the unit and the foundation (the shock absorber itself has anti-slip and anti-roll functions and does not need to be fixed on the foundation).

Model	Code (mm)														Spring damper absorber	
	A	B	C	D	E	F	G	H	I	J	K	L	M	N	Model	Quantity
TASF225.1AA/JC1T1 TASF240.1AA/JC1T1 TASF225.1AAC1T3 TASF245.1AFC1T1	2170	1588	1588	1588	1588	-	-	-	-	-	-	-	-	-	MHD-920	10
TASF265.1AFC1T1 TASF285.1AFC1T1	2170	1300	1300	1300	1300	1300	1300	-	-	-	-	-	-	-	MHD-730	14
TASF140.2AA/JC1T1 TASF160.2AA/JC1T1 TASF140.2AAC1T3 TASF160.2AAC1T3 TASF150.2AFC1T1 TASF165.2AFC1T1	2184	1390	1390	1390	-	-	-	-	-	-	-	-	-	-	MHD-1050	8
TASF180.2AA/JC1T1 TASF205.2AA/JC1T1 TASF180.2AAC1T3 TASF205.2AAC1T3 TASF200.2AFC1T1	2184	1588	1588	1588	1588	-	-	-	-	-	-	-	-	-	MHD-1050	10
TASF240.2AA/JC1T1 TASF240.2AAC1T3 TASF225.2AFC1T1 TASF240.2AFC1T1	2184	1588	1588	1588	1588	-	-	-	-	-	-	-	-	-	MHD-1200	10
TASF260.2AA/JC1T1 TASF280.2AA/JC1T1 TASF260.2AAC1T3 TASF280.2AAC1T3 TASF260.2AFC1T1 TASF290.2AFC1T1	2184	1255	1255	1255	1255	1255	1255	1255	1255	-	-	-	-	-	MHD-810	16
TASF310.2AA/JC1T1 TASF310.2AAC1T3 TASF300.2AFC1T1 TASF330.2AFC1T1	2184	1255	1255	1255	1255	1255	1255	1255	1255	-	-	-	-	-	MHD-850	16
TASF340.2AA/JC1T1 TASF360.2AA/JC1T1 TASF375.2AA/JC1T1 TASF410.2AA/JC1T1 TASF340.2AAC1T3 TASF360.2AAC1T3 TASF375.2AAC1T3 TASF410.2AAC1T3 TASF345.2AFC1T1 TASF380.2AFC1T1 TASF395.2AFC1T1 TASF430.2AFC1T1	2184	1240	1240	1240	1240	1240	1240	1240	1240	1240	-	-	-	-	MHD-810	20
TASF445.2AA/JC1T1 TASF475.2AA/JC1T1 TASF445.2AAC1T3 TASF445.2AFC1T1 TASF485.2AFC1T1	2184	1240	1240	1240	1240	1240	1240	1240	1240	1240	-	-	-	-	MHD-850	20

★ Notes

1. Foundation levelness ≤ 0.1%;
2. The bearing capacity of foundation ≥ 1.5 times of the operating weight of unit;
3. Drainage ditches must be provided around the foundation to prevent accumulation of water;
4. Shock absorbers must be installed between the unit and the foundation (the shock absorber itself has anti-slip and anti-roll functions and does not need to be fixed on the foundation).

# On-Site Wiring Diagram

## Single compressor

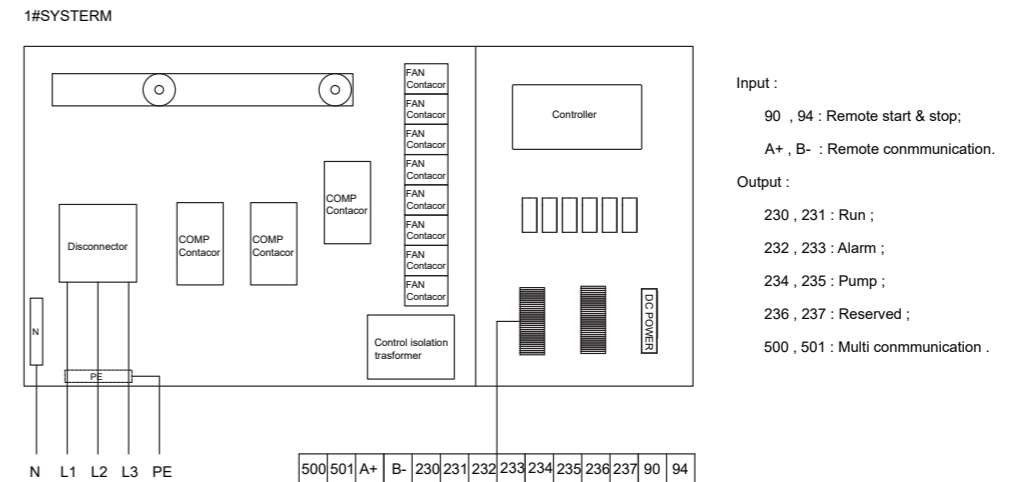

## Dual compressors

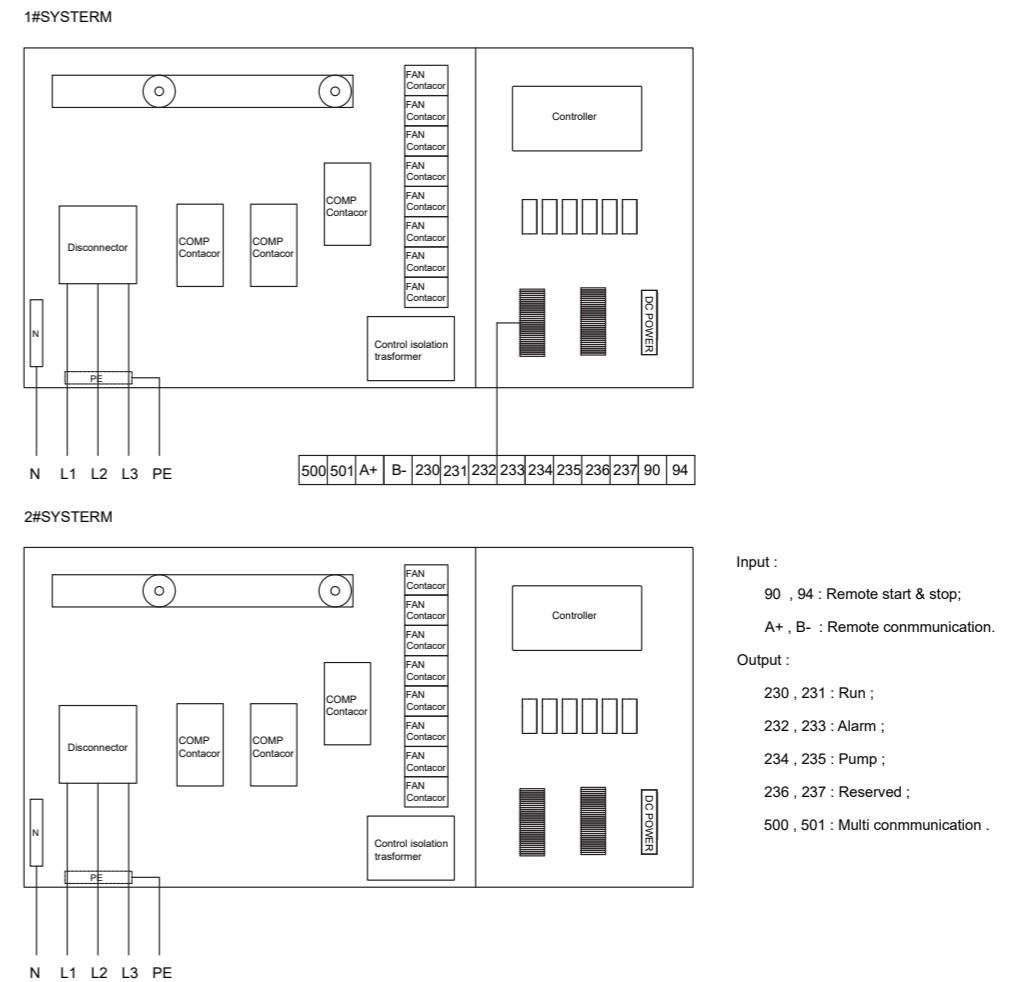

# Installation and Debugging

The unit installation and maintenance must be carried out by professionals who have received professional training, get familiar with the local standards and rules, and have practical operation experience and qualifications of refrigeration equipment. The first operation of the unit must be carried out by the professional service department; otherwise, the quality of the unit is hardly guaranteed.

## Handling of Unit

The entire unit is transported, and the refrigerant required for normal operation has been charged in the unit. Handle the unit carefully, avoiding damages to it due to reckless operation or refrigerant leakage.

## Acceptance Upon Delivery at Site

After arrival of the equipment, carefully check whether all the items are complete against the packing list, and whether the parts are damaged during transportation; if any parts are damaged, notify the forwarder and put forward a written compensation request. Our company will not bear the liability for compensation for any damages that arise after the acceptance of the goods.

## Lifting of Unit

Be sure to use a cable twisted rope or chain with a sufficient bearing capacity to fasten the steel pole passing through the lifting hole on the unit base to lift the unit, and operate according to the requirements of the lifting diagram; make sure that the panel of the fins and other parts of the unit are not damaged, and note to use special lifting equipment such as spreader bar and cradle to protect the unit during lifting; do not tilt the unit by more than 30°.

## Foundation Requirements

The unit should be placed on a horizontal plane foundation, bottom floor or building roof that can bear the operating weight of the entire equipment. Please refer to the unit nameplate for the operating weight. Spring damper absorbers must be provided if the unit is to be installed on a building roof so as to avoid vibration and noise transmission. If the unit location is too high which makes it inconvenient for the maintenance personnel to conduct maintenance, it should set up appropriate scaffolds around the unit and the scaffolds must bear the weight of maintenance personnel and equipment. (You may refer to some of the requirements on the Foundation Drawing of Unit above).

## Environmental Requirements

It is better to install the unit in a relatively spacious area where sufficient air can flow by the fin coil. There should be enough spacing around the unit to allow air to flow into the fin coil and such space can also be used as maintenance passages. (You may refer to some of the requirements on the Diagram for Installation Space of Unit above). It is proper to use the unit in a region with an ambient temperature above -15°C. In areas with snowfalls in winter where the unit also needs to operate in winter, the installation height must be increased and it is recommended to install a snow cover for the unit if there may be snow accumulation at the installation site so as to ensure normal air flow by the fin coil.

## Water Pipe Installation

Check valves must be installed at the unit inlet and outlet to facilitate routine maintenance of the water system. It is suggested to install a thermometer and a pressure meter at the water inlet/outlet of the heat exchanger of the unit in order for ease of regular inspection and repair; A water filter should be installed at the water inlet of the pump and the heat exchanger; It should check the water tightness of the pipeline before the pipe is wrapped with thermal insulation materials and before the water enters the unit; All pipelines connecting to the unit should be installed with a vibration damping device; A flow control device meeting the requirements must be installed; The blow-off pipe installed for the air conditioning engineering system must keep away from the inlet and outlet water pipelines of the heat exchanger of the unit, otherwise it will the normal operation of the unit.

## Water Quality Requirements

The compositions of water in various regions are relatively complicated. If water different from the common water quality is used, the water should be tested before entering the heat exchanger of the unit. If the water quality does not meet the requirements of air conditioning water, water treatment is required. For water treatment, see the Code for Design of Industrial Recirculating Cooling Water Treatment or other relevant standards. See the following table for reference indexes.

Item	Unit	Allowable values required by air conditioning water
Suspended substance	mg/L	< 10
pH value (25°C)	mg/L	6.5 - 8.0
Conductivity (25°C)	μS/L	< 800
Methyl orange alkalinity	mg/L	< 150
Acid consumption (PH = 4.8)	mg/L	< 100
Total hardness CaCO <sub>3</sub>	mg/L	< 200
Fe <sup>2+</sup>	mg/L	< 1.0
Cl <sup>-</sup>	mg/L	< 200
SO <sub>4</sub> <sup>2-</sup>	mg/L	< 200
SiO <sub>2</sub>	mg/L	< 50
NH <sub>4</sub> <sup>+</sup>	mg/L	< 1.0
S <sup>2-</sup>	mg/L	Cannot be detected
Free chlorine	mg/L	< 1.0
Petroleum category	mg/L	< 5

# Water Pipe Connection Diagram

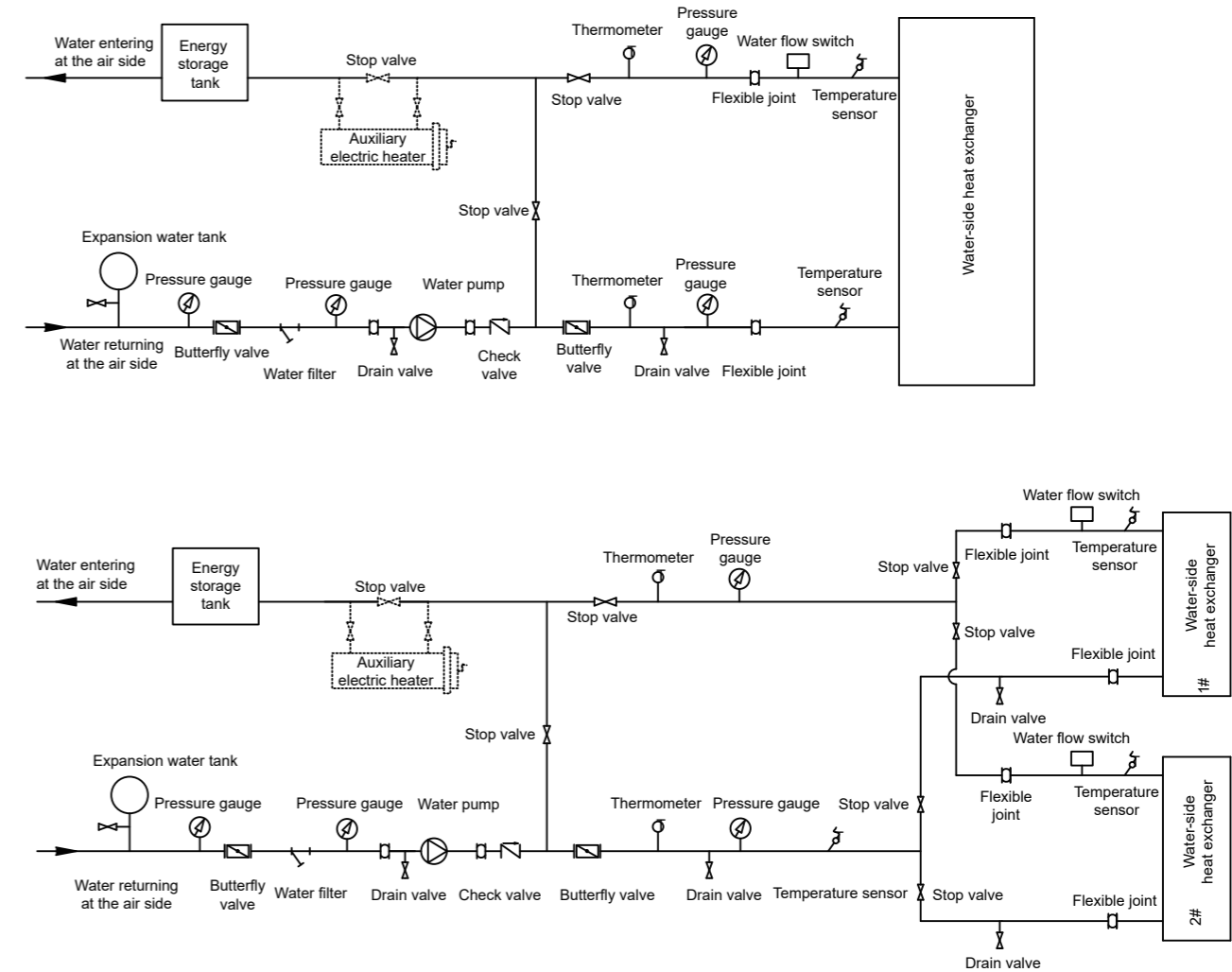

## ★ Notes

- Water cycling system shall be designed as simple as possible and avoid the use of too many elbows. Straight pipes shall be arranged on the same plane where possible.
- Pay attention to the locations of water inlet and outlet of the heat exchanger to prevent connection errors.
- Install manual or automatic air release valve at the top points of water cycling system.
- Expansion tank shall be anti-corrosive and rust proof and installed at the top points of entire pipeline system.
- Install a thermometer and pressure meter at the water inlet and outlet.
- For the dual-compressor unit, a temperature sensing blind pipe shall be reserved at the user's general water pipe in order to further install a temperature sensor.
- Water drain valves should be installed at the bottom of elbows to make sure the water in the whole unit is emptied.
- Install a stop valve at the pipeline connecting the heat exchanger of the unit to the user's water pipe.
- Install a bypass valve between the water inlet pipe and the water outlet pipe of the heat exchanger of the unit in order for ease of maintenance and pipeline washing.
- Install flexible joints to reduce vibration of pipelines.
- Impurities in the water system will cause fouling and scaling on the heat exchanger, so a filter should be installed upstream the pump.
- To boost cooling performance and save energy, pipelines shall be completely insulated.
- To prevent frequent breakdowns of the unit caused by too small load, it is recommended to use energy storage tank.

## Selection of Water System Parts

<b>Stop Valve</b>	Determine the valve according to the water pipe diameter. Usually the pipe diameter of the selected valve is identical to that of the connecting pipe of the unit.
<b>Water Filter</b>	It is used to filter the impurities from the water system. Usually select a filter with more than 60 meshes.
<b>Check Valve</b>	It is installed at the water pump outlet to prevent damage to the water pump when water flows back. The diameter of the valve pipe is identical to that of the connecting pipe of the unit.
<b>Bypass Valve</b>	It is installed between the inlet water pipe and outlet water pipe of the unit vessel. Open this valve when cleaning the pipeline.
<b>Thermometer</b>	It is used to facilitate overhaul and maintenance of the unit and to observe the operating status of the unit. Usually the range of it is selected from 0°C to 100°C.
<b>Water Pump</b>	The water capacity of water pump is selected according to the water flow parameters of the unit: Water capacity of pump = $L \times 1.1$ (L— water flow of the unit); the pump lift is calculated according to the following formula: Pump lift = [water resistance of the unit + most unfavorable pipe length $\times$ (2%- 5%) + water resistance at the end of the most unfavorable path] $\times$ 1.1.
<b>Automatic Air Discharge Valve</b>	It is used to discharge air from the water system and make the unit operate normally. It is installed at the highest point of the system.
<b>Expansion Water Tank</b>	It is mainly used to contain the excessive water, stabilize water pressure in the system, and supplements water to the system. Generally it is installed at the return water pipe, higher than the water pipe in the system, so that the unit can operate properly. Its capacity is calculated according to the following formula: Expansion water tank volume $V=(0.03 \text{ to } 0.034) V_c$ $V_c$ —System water capacity
<b>Energy Storage Water Tank</b>	It is used for energy regulation to reduce frequent start/stop times of the compressor when the air conditioning system load changes so as to increase the system operation efficiency and to prolong the service life of the unit. Its capacity is calculated according to the following formula: Energy storage tank volume $V (m^3) = (Q/27.9n) - V_s$ $Q$ — Cooling capacity (kW) $n$ — Number of heads $V_s$ — Water capacity in the pipeline of the chilled water system and in the heat exchanger $m^3$

★ Notes

The tested pressure value of the pipeline pressure test is greater than 1.25 times the operating pressure, but not less than 0.6 MPa. When the pressure is maintained for 5 minutes, the pressure drop is not greater than 0.02 MPa. The system is qualified when leakage is not detected.

The water pressure test cannot be performed when the air temperature is lower than 5°C. The pressure meter for the pressure test is qualified, with the precision not lower than grade 1.5, and the full scale value is 1.5 to 2 times the maximum tested pressure.

Water is added from the lower part of the system and air is discharged from the upper part. During the pressure test, add water slowly and evenly to reach the pressure, stop the pump, and check the system. Repair cannot be performed when there is pressure in the system.

After the pressure test is qualified, rinse the water pipeline repeatedly (do not pass the equipment) till impurities such as silt and iron filings are not contained in the drained water and water is clear.

## Routine Maintenance

TICA recommends the user record the routine operating data of air-conditioning equipment and regularly carry out maintenance.

1. Before using the unit for the first time, check the functioning of the air side equipment and other parts of the water system.
2. (Recommended) Use the following service schedule to maintain the unit:

Daily inspection	1. Check whether the unit generates any alarm
	2. Check whether the air discharge and air suction pressures and oil pressure are normal
	3. Check whether the oil level is normal (check through the oil sight glass to ensure proper amount of oil)
	4. Check for any abnormal compressor or fan noise
	5. Check for odors inside the startup cabinet and control cabinet
	6. Check whether the temperature sensor and temperature probe are securely fixed
	7. Check for any appearance damage of the unit and whether heat exchanger or discharge fan is blocked
	8. Check whether the water pump and valve function normally
	9. Check the appearance of water pipes for damages and leakage
Monthly inspection	1. Check the coil of compressor oil (the oil should be clear and clean; if the color turns dark brown or muddy, replace the oil; if the oil turns black, disassemble and inspect the compressor)
	2. Check the color of the test paper in the sight glass of liquid supply pipe (yellow indicates that the refrigerant has excessive water content)
	3. Check for leakage in the refrigerant loop (whether there is any greasy dirt or sound of leak)
	4. Clean the startup cabinet and control cabinet
	5. Check cleanness of the water line filter, and clean the filter when necessary
	6. Check the water quality, and send the water sample for laboratory analysis if possible (water quality should comply with the standard Code for Design of Industrial Recirculating Cooling Water Treatment or other relevant standards)





---

**TICA PRO LLC**

Tel. +7(495)127-79-00

E-mail: [info@tica.ru](mailto:info@tica.ru)

Website: <https://en.tica.pro/>

---



Note: Due to constant improvement and innovation of TICA's products, the product models, specifications and parameters contained in this document are subject to change without prior notice.