

INSTALLATION & OPERATION MANUAL

INVERTER MULTI SYSTEM UNIT

Applicable to: TIMS-CSREA Series

Contents

Safety Precautions	5
Installation of ODU	6
Dimensions	6
Installation space	7
Handling	9
Placement	9
Installation of refrigerant piping	11
Caution:	11
Diameters of refrigerant piping	14
Installation of branch pipes	14
Limits for refrigerant piping	17
Air tightness test, vacuuming and supplementing refrigerant	18
Air tightness test	18
Vacuuming	18
Supplementing refrigerant	19
Electrical control installation	20
Wiring cautions	20
Wiring specifications	21
Electrical wiring	22
Communication wiring	22
Illustration on control board of ODUs	23
Code settings	23
Settings of relevant keys	25
Digital display	27
Trial Operation	29
Before trial operation	29
Trial Operation	29
Trial operation check	30
Description of hazardous substances	31

Application Form for Debugging Independent Inverter VRF Air Conditioning Unit by Installer

Full name of installer: _____

Address of installer: _____

Owner's name or employer: _____

Person to contact: _____ Tel: _____

Installation site: _____ Province City _____

Unit model: _____

IDU bar code: _____

ODU bar code: _____

Distributor: _____

Tel: _____

Installer: _____

Tel: _____

Person to contact: _____

Fax: _____

Person to contact: _____

Fax: _____

The following items are to be filled by the installer correctly, so that the debugging can be arranged in due time. In case the form contents are different from the real situation, causing the experts unlikely to conduct debugging on site, the installer must be liable for labor and travelling expenses incurred to the debugging experts.

Contents to be Checked and Confirmed by Installer

Before installation, ask the installer to carefully read through the manuals and relevant requirements attached to the unit.

1. Check installation position

a. Whether heat dissipation and ventilation for ODU meets requirements for distance	Yes ()	No ()
b. Whether ODU is installed on a base firmly and with vibration damping measures applied	Yes ()	No ()
c. Whether IDU is provided with vibration damping measures and properly fastened	Yes ()	No ()
d. Whether there is space for maintenance	Yes ()	No ()

2. Check electrical system before installation

a. Whether air switch capacity and power wire diameter meet unit requirements	Yes ()	No ()
b. Whether correctly wired and whether wiring terminal is pressed and completely connected	Yes ()	No ()
c. Whether neutral line and grounding wire are connected in accordance with electrical codes	Yes ()	No ()
d. Whether the distribution of control wire and power wire meets anti-interference requirements	Yes ()	No ()
e. Whether the length of control wire and power wire is proper	Yes ()	No ()

3. Check refrigerating system before installation

a. Whether refrigerant duct meets factory requirements in terms of its diameter and thickness	Yes ()	No ()
b. Whether the length of refrigerant duct meets relevant requirements	Yes ()	No ()
c. Whether added nitrogen for welding refrigerant duct to protect air conditioning unit	Yes ()	No ()
d. Whether cleaned refrigerant duct	Yes ()	No ()



e. Whether used nitrogen for holding pressure to test leakage	Yes ()	No ()
f. Whether vacuumized refrigerating system against installation manual	Yes ()	No ()
g. Whether supplemented refrigerant according to standard	Yes ()	No ()

NANJING TICA CLIMATE SOLUTIONS CO., LTD. Fax: 86258532309 E-mail: tica@ticachina.com

Application Form for Debugging Independent Inverter VRF Air Conditioning Unit by Installer

4. Check air duct system before installation		
a. Whether the installation of air duct system is designed by professionals	Yes ()	No ()
b. Whether external residual pressure matched actual resistance of air duct	Yes ()	No ()
c. Whether air duct system is provided with static pressure box for air supply and return	Yes ()	No ()
d. Whether air flow organization of indoor air supply and return is reasonable	Yes ()	No ()
e. Whether air duct is insulated	Yes ()	No ()
f. Whether air valve is reasonably set	Yes ()	No ()
h. Whether return air inlet or IDU is equipped with filter and make sure they are clean	Yes ()	No ()
i. Whether equipped with air return duct in the case of ceiling air return	Yes ()	No ()
j. Whether there is fresh air device	Yes ()	No ()
k. Air supply and return mode: 1 bottom air supply and side air return: 2 side air supply and side air return	Yes ()	No ()
5. Check indoor condensate water system before installation		
a. Pour water into drain pan to check whether condensate water could be discharged smoothly and whether there is leakage	Yes ()	No ()
b. Check whether condensate water pipe is tightly sealed to prevent condensation on the surface of pipe	Yes ()	No ()
c. Whether water trap is designed in accordance with the manual attached to the unit	Yes ()	No ()
6. Preparation before debugging		
A. Whether the power supply voltage is within the normal range of the unit and whether the three-phase degree of balance is less than 2%	Yes ()	No ()
b. Ensure the power is not temporary	Yes ()	No ()
c. Whether the clients and Party A's inspection experts are in place in time	Yes ()	No ()
d. Whether there are sufficient facilities (ladder and lifting table etc.) to ensure normal work of operators	Yes ()	No ()
e. Whether the unit is pre-heated for 24 hours before powering on for debugging	Yes ()	No ()
7. Other circumstances		
Date of requiring debugging: Before _____.		
Applicant (seal):		
Signature:		Date:

Safety Precautions



Caution: Read this manual carefully before installation and use of the unit.

The following standard is applied to this product:

GB/T 18837-2015 JB8655-1997

This installation manual is applied to TICA TIMS-CSREA series independent R410A inverter VRF air conditioning units. The manual is subject to change based on improvement on air conditioners without further notice.

Preparation before installation

- Installation shall be left to a licensed professional. Users shall not install, repair or displace the air conditioning unit by themselves.
- Be sure to use a dedicated power circuit. Make sure the supply voltage fluctuates within $\pm 10\%$ of rated voltage. Power supply should be separate from welding transformer because the latter may cause large voltage fluctuation.
- Get a licensed electrician to install the unit according to national and local power standard, and to check whether line capacity meets requirements and whether power lines are loose or damaged.
- "Electrical control schematic diagram" is attached to the back side of cover plate of ODU control box. Please keep the manual properly for further reference.

Precautions during installation

- Do not touch heat exchanger fins. Otherwise, it may cause damage to the fins or reduced performance for the unit or finger injury.
- The cover plate for control box must be fastened to

prevent incoming of dust and water. The electrical parts must be waterproof and away from water sources, otherwise electric shock or fire may be caused.

- After installation, be sure to make an air tightness check whether there is pipeline leakage.

Precautions for using R410A refrigerant devices

- Please supplement refrigerating system with liquid refrigerant. In the case of gaseous refrigerant, composition of refrigerant in the system may change.
- Do not mix into other refrigerants.
- Do not use the following tools ever used for common refrigerants (such as R22): pipeline pressure test devices, filling hoses, leakage detection devices, refrigerant filling base, and refrigerant recovery devices.
- Make sure to use vacuum pump dedicated for R410A series.

Precautions at trial operation

- When the system is powered on for the first time or after being left unused for a long time, ODU power must be connected 24 hours before use. Otherwise, the

compressor may be burnt (make sure the air conditioner is in standby mode at the seasons they are needed most).

- Do not turn on the air conditioner when the panel or protection screen is removed. The moving parts inside the air conditioner may hurt people or other objects.

- Do not touch refrigerant pipeline during operation or just at the end of operation.

The pipeline of the air conditioner may be very hot or cold during its operation, which may lead to scald or frostbite.

- Do not turn off power immediately after the unit stops. Wait at least for five minutes, otherwise water leakage may occur.

- Please cut off general power supply during seasons the air conditioners are not used, so as to prolong the service life and save energy.

- All the IDUs and ODUs of the same system must be supplied with power simultaneously.

Installation of ODU

Standard model

ODU capacity is indicated by its cooling capacity with the unit kW

Model	TIMS252CSREA	TIMS285CSREA	TIMS335CSREA
Cooling capacity	25.2kW	28.5kW	33.5kW
Maximum number of IDUs	14	16	19

Dimensions

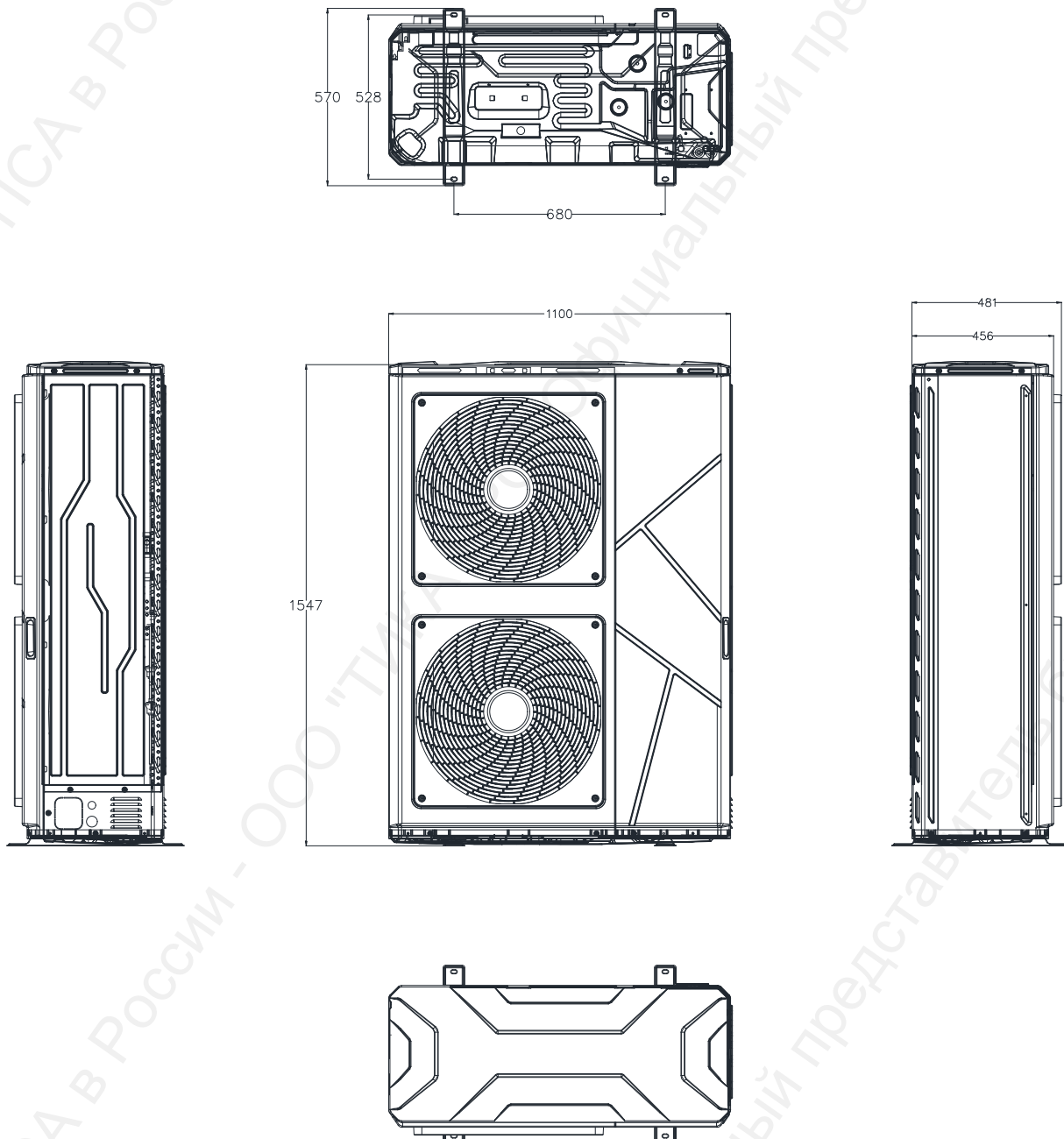

Installation of ODU

Installation space

Requirements for installation position

- The installation position shall have sufficient strength to bear the unit weight and its vibration during operation. If the ODU is installed on a roof, make sure the roof is strong enough and water-proof.
- The ODU shall be installed in a well ventilated place to ensure good heat exchange.
- Places unsuitable for installation:
 - ▲ The place where acid or alkaline substance or corrosive gas (e.g., sulfur dioxide and hydrogen sulfide) may be produced, easily corroding the unit and leading to refrigerant leakage.
- Places where air conditioning units must not be installed:
 - ▲ The place where flammable gas or volatile combustibles may be produced. If flammable gas leaks and accumulates around the unit, the unit may explode.
 - ▲ Do not install the ODU where it is exposed directly to strong wind or typhoon. When conditions permit, add auxiliary equipment to prevent water, snow or direct sunshine.

Requirements for ODU installation space:

- Make sure there is enough space above the unit.
- The side with TICA symbol attached shall be the front side of ODU.
- The space required for installing or maintaining an ODU is shown in the following figure.

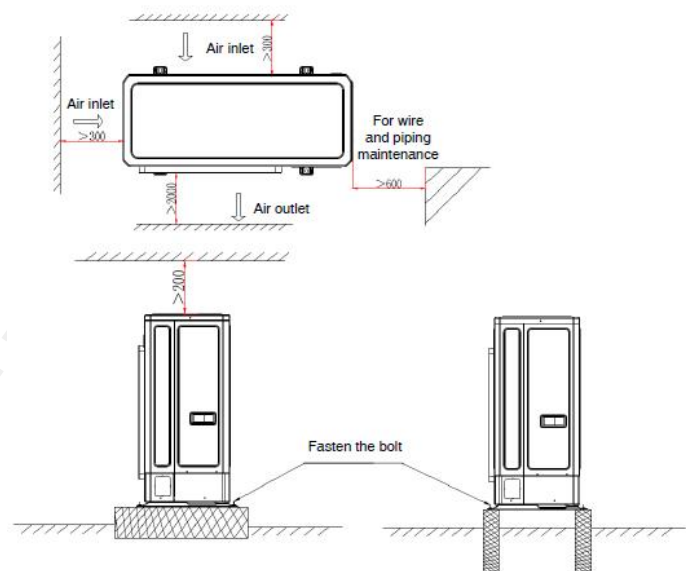

Installation of ODU

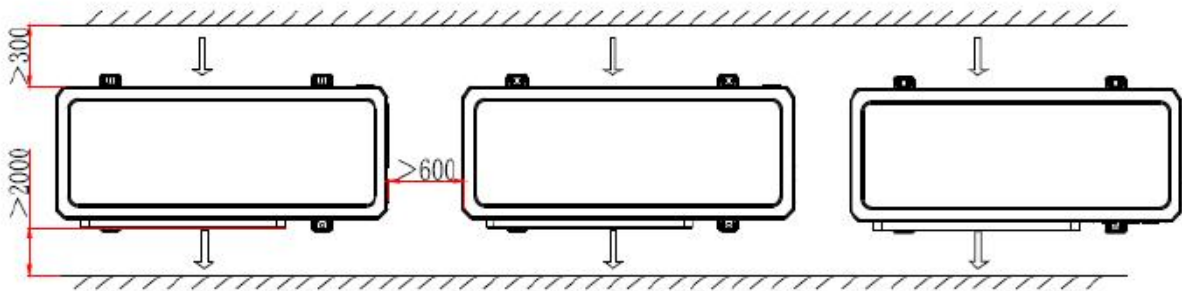
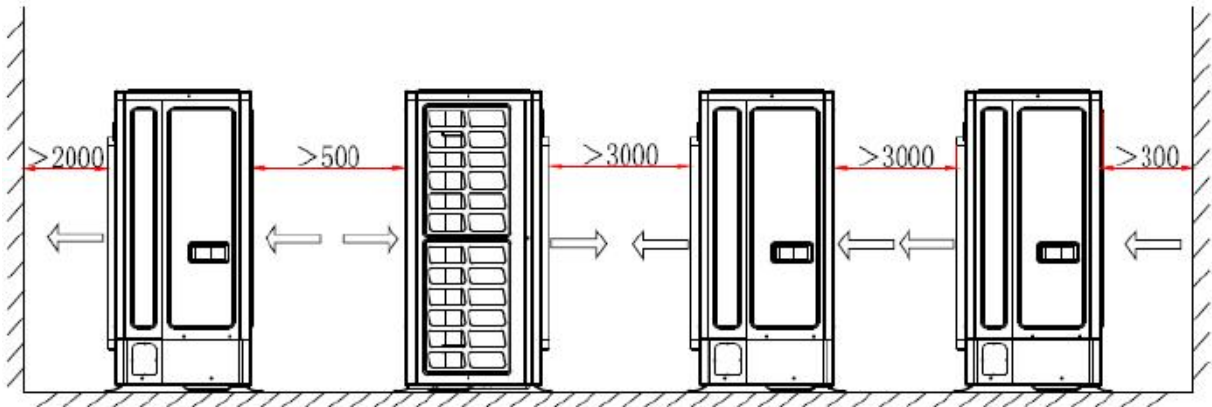

Installation of ODU

Handling

Caution:

- Fragile and handle with care.
- The degree of inclination shall not exceed 30° while handling (do not put the unit on its side).
- Keep heat exchange fins safe while handling and installing the unit. In case of any damages, please use fin comb to fix it up.
- Properly dispose of packaging bags and prevent kids from playing with them.

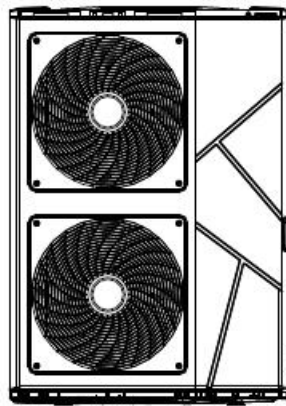

- Use forklift to handle: be careful when inserting the fork into the pocket at the bottom, and prevent fork from damaging the unit or the unit bottom.
- Use crane to handle: tighten hoisting rope according to what is shown in the figure, and keep the unit weight even during hoisting.
- Use two hoisting ropes at least 8 m long and about 20 mm in diameter to support the unit weight. Do not use tying band of the unit for handling.
- After the wooden framework is removed: use paper or cloth as pad between hoisting rope and the unit to prevent damages to the unit body.

Placement

- Make sure the ODU is placed firmly at a level place to prevent vibration and noises.
- Use a base larger than the width of ODU's support legs (66 mm) to support the unit.
- The shock-absorbing pads shall cover the entire bearing surface of the base.
- The unit base shall be at least 200 mm higher above the ground.
- Around the base there should be drain to ensure that the condensate water generated during operation could flow out.

Installation of ODU

- Concrete foundation: the foundation shall be above the ground for at least 150 mm.

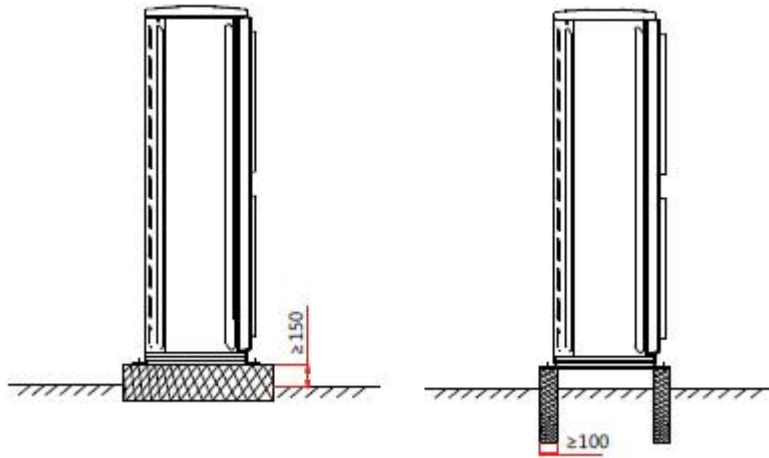

- Use anchor bolts, nuts and pads to fasten the ODU tightly to the base. Caution: shock-absorbing pads need to cover the entire bottom of the unit, and the pad thickness is greater than or equal to 20 mm.
- For anti-corrosive models: use rubber pads. If the nut joints get loose, the unit will not be corrosion proof.

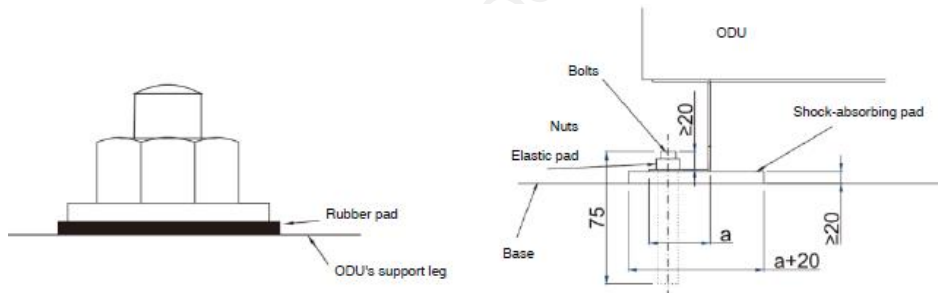

Installation of refrigerant piping

Caution:

- Use clean piping that is free from dust, moisture or any other substances.
- Store all the pipelines needed for installation indoors, and keep two ends of pipelines sealed till welding.
- Pass copper pipes into the holes at wall and seal the holes to prevent dirt coming in.
- Do not do ODU piping work on rainy days, lest that moisture and dirt would enter the pipelines.
- Try to reduce bended piping and use bends with larger radius.
- When connecting refrigerant piping, the stop valve of ODU shall be closed completely after refrigerant piping between ODU and IDU is done, and refrigerant leakage test and vacuumizing process are finished.

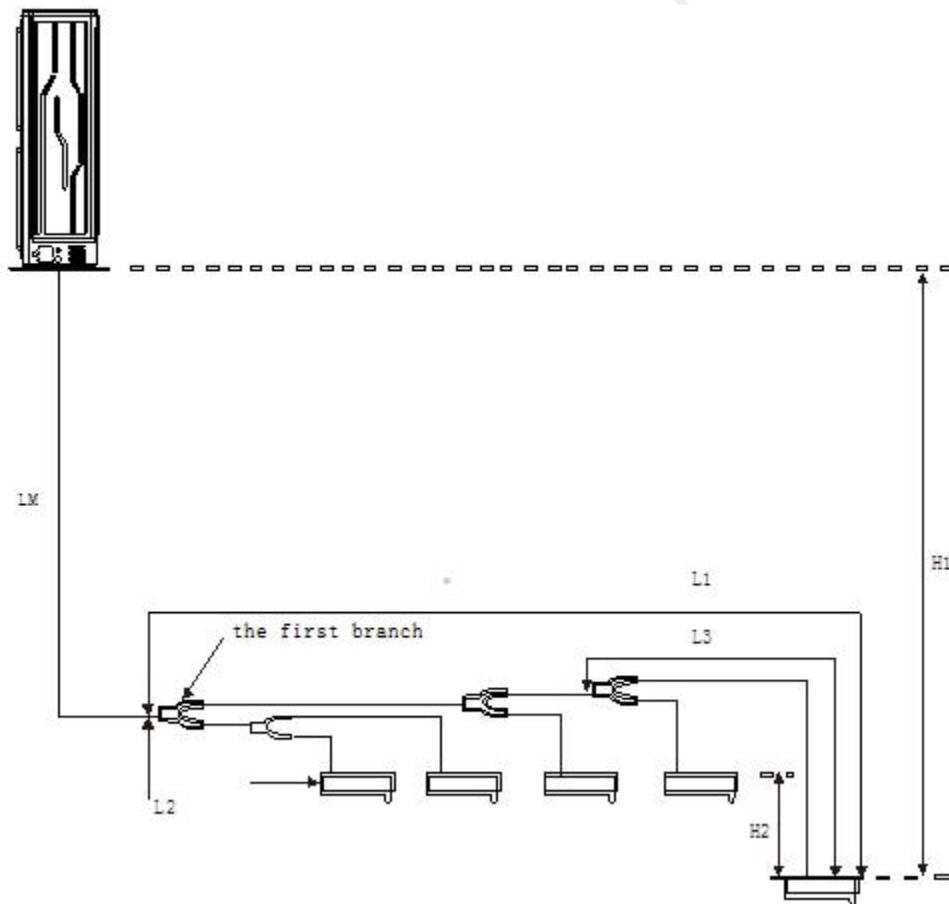

Installation of refrigerant piping

	Definition	Limit (actual length)	Remarks
H1* ¹	Level difference between the IDU and ODU	When the ODU is at the upper position: < 50 m When the ODU is at the lower position: < 40 m	
H2* ¹	Level difference among IDUs	< 20 m	
L1* ²	Equivalent longest piping distance from the IDU to the first branch pipe	< 40 m	
LM	Piping from the ODU to the first branch pipe on the indoor side	< 90 m	> 40 m: Increase the size of main pipe by one
L1-L2	(Longest piping distance from the IDU to the first branch pipe on the indoor side) - (Shortest piping distance from the IDU to the first branch pipe on the indoor side)	< 40 m	
L3	Distance from the IDU to the nearest branch pipe	< 40 m	
Total L	Total length of piping (total length of all liquid pipes or all gas pipes of the system)	Equivalent length < 1000 m	

*1: Contact TICA's engineers when exceeding the above limits.

*2: If it exceeds 40 m, the remarks on the next page shall be met.

Diameters of branch pipe of the IDU

The IDU is equipped with branch pipes h~p. Refer to the following table for the selection of the branch pipe size.

Unit: mm

IDU capacity	When the length of the branch pipe ≤ 10 m (outer diameter × minimum wall thickness)		When the length of the branch pipe > 10 m (outer diameter × minimum wall thickness)	
	Gas side	Liquid side	Gas side	Liquid side
A<71	φ12.7×0.8	φ6.35×0.8	φ15.9×1.0	φ9.5×0.8
A≥71	Piping according to the normal pipe diameter			

Note: In order to ensure the best use effect of the IDU, control the length of the branch pipe within 10 m (shall not exceed 30 m), otherwise the indoor heat exchange effect will be affected.

Installation of refrigerant piping

Remarks: The equivalent longest piping distance from the IDU to components of the first branch pipe shall be no more than 40 m. However, when all the following conditions are met, it is allowed to extend the length to 90 m. (in the case of "using TICA branch pipe".)

Required conditions	Legends	
1. The diameter of the pipe between the components of the first branch pipe and those of the last branch pipe needs to be increased. (Make the variable diameter pipe on the site); If the piping diameter is the same with that of the main pipe, it does not need to be increased.	$b + c + d + e + f + g + p \leq 90 \text{ m};$ The piping diameters of b, c, d, e, f, g needs to be increased	The piping size shall be increased as follows $\varphi 9.5 \rightarrow \varphi 12.7$ $\varphi 12.7 \rightarrow \varphi 15.9$ $\varphi 15.9 \rightarrow \varphi 19.1$ $\varphi 19.1 \rightarrow \varphi 22.2$ $\varphi 22.2 \rightarrow \varphi 25.4$ $\varphi 25.4 \rightarrow \varphi 28.6$
2. When calculating the total extension length, the actual length of the preceding pipes must be doubled. (Except for main pipe and pipes without increased pipe diameter.)	$a + b \times 2 + c \times 2 + d \times 2 + e \times 2 + f \times 2 + g \times 2 + h + i + j + k + l + m + n + p \leq 1000 \text{ m}$	
3. Distance from the IDU to the nearest branch pipe component $\leq 40 \text{ m}$	$h, i, j, l, m, n, p \leq 40 \text{ m}$	
4. Distance difference between (the ODU to the farthest IDU) and (the ODU to the nearest IDU) $\leq 40 \text{ m}$	Farthest IDU-nearest IDU $(a + b + c + d + e + f + g + p) - (a + h) \leq 40 \text{ m}$	

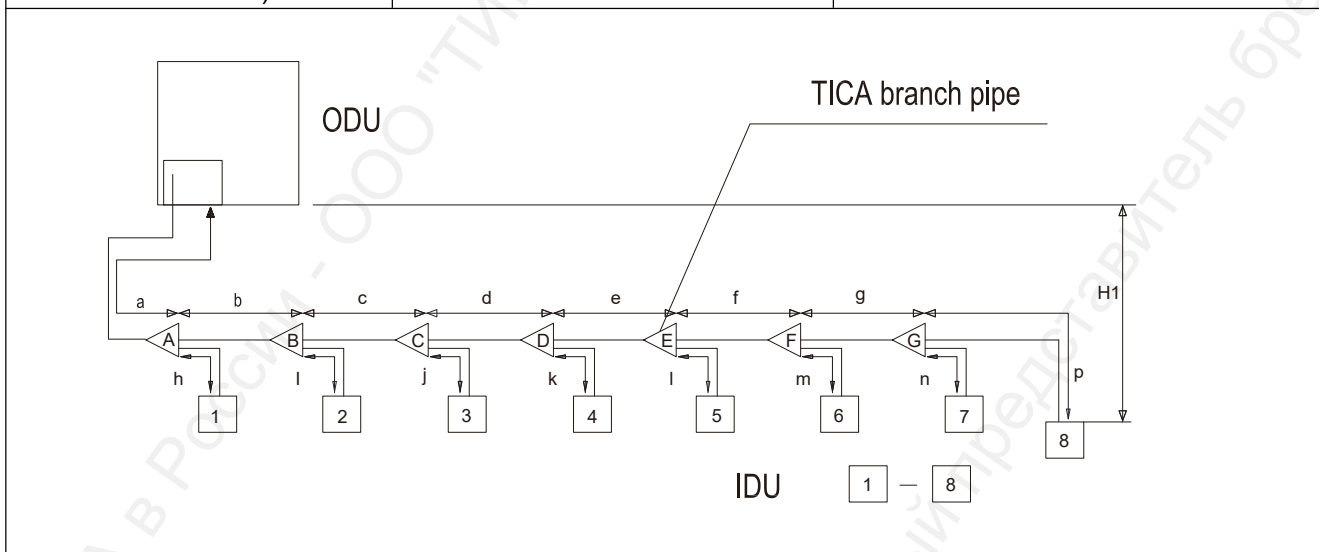

Installation of refrigerant piping

Diameters of refrigerant piping

The size of the copper pipe of the main pipe in the figure shall be selected from the following table based on the capacity of its upstream ODU.

ODU model	Piping length (LM + L1) < 90 m Main pipe length (LM) < 40 m		Piping length (LM + L1) < 90 m Main pipe length (LM) > 40 m		Piping length (LM + L1) > 90 m	
	Liquid pipe (mm)	Gas pipe (mm)	Liquid pipe (mm)	Gas pipe (mm)	Liquid pipe (mm)	Gas pipe (mm)
TIMS252CSREA	12.7	22.23	12.7	25.4	15.88	25.4
TIMS285CSREA	12.7	22.23	12.7	25.4	15.88	25.4
TIMS335CSREA	12.7	25.4	12.7	28.58	15.88	28.58

- The piping between the last-level branch pipe and IDU shall have the same sizes with IDU piping.
- The piping between branch pipes shall be based on the total capacity of downstream IDUs connected to the piping.

Total capacity of connected IDUs	Liquid pipe specifications (mm)	Air pipe specifications (mm)
$X < 16.8$	φ 9.52	φ 15.88
$16.8 \leq X < 22.5$	φ 9.52	φ 19.05
$22.5 \leq X < 33.0$	φ 9.52	φ 22.23
$33.0 \leq X$	φ 12.7	φ 25.40

Remarks: The size of the piping between branch pipes shall not be greater than that of copper pipe at Place A in the figure above.

Installation of branch pipes

- Branch pipes shall be selected based on the total capacity of downstream IDUs connected:

Total capacity of downstream IDUs connected to branch pipes	Model of branch pipes
$X < 16.8$	TBP4022TA
$16.8 \leq X < 22.5$	TBP4022TA
$22.5 \leq X < 33.0$	TBP4033TA
$33.0 \leq X$	TBP4072TA



The model of branch pipe components and the diameter of main pipe and branch pipe shall be confirmed against working drawings and installation instructions. There should not be sharp turns (90° angle) or other branch pipe components falling within 500 mm of branch pipe components. The straight pipe distance between two adjacent branch pipes shall not be less than 1000 mm.

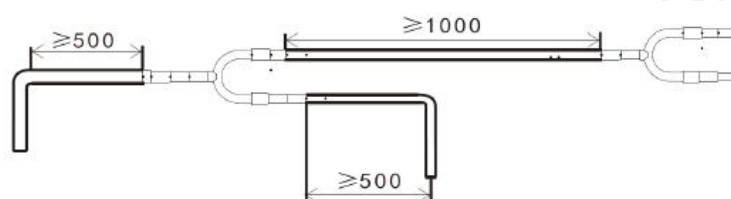

Installation of refrigerant piping

- ⚠** Branch pipes can be vertically or horizontally installed and as close as possible to the IDU.
When installed horizontally, the angle shall be between $\pm 15^\circ$.

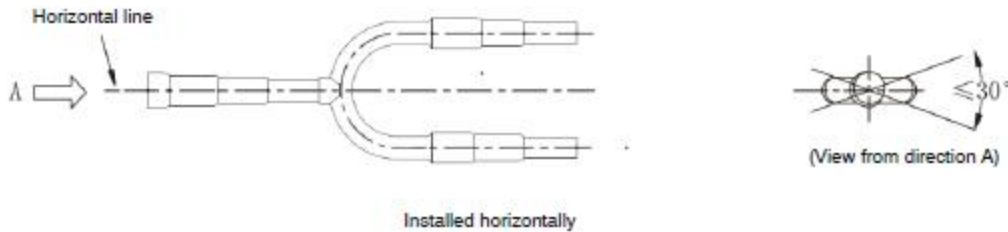

See the following figure when branch pipes are installed vertically.

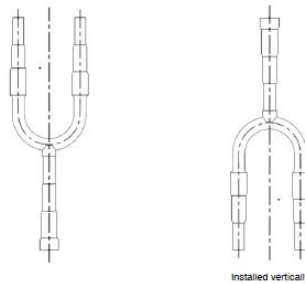

- Size of branch pipes:
TBP4022TA

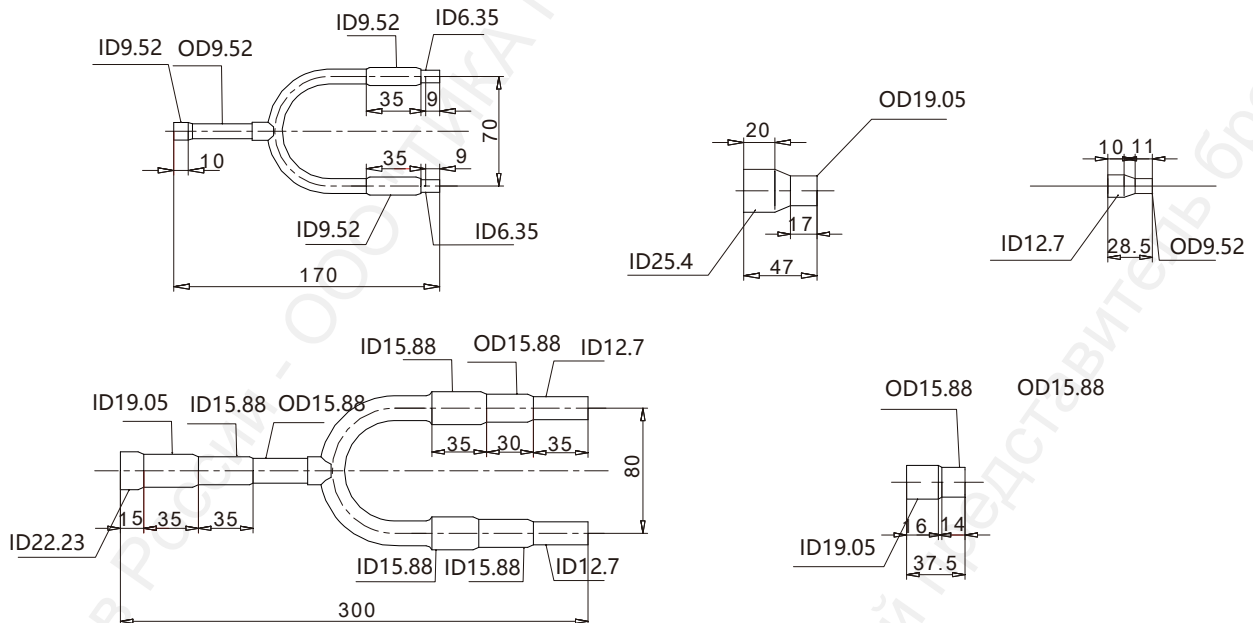

Installation of refrigerant piping

TBP4033TA

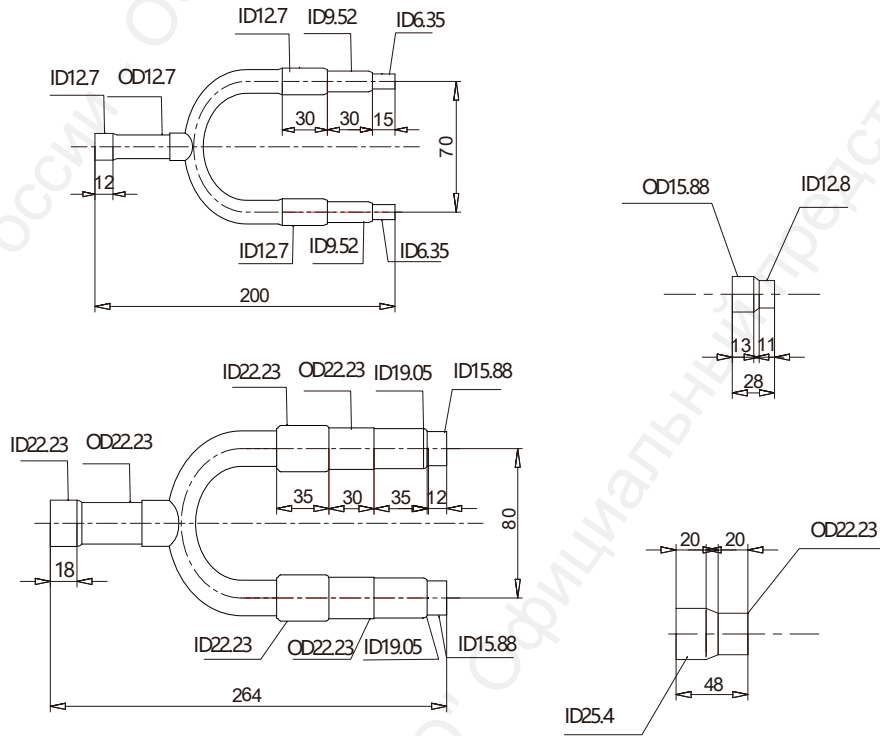

TBP4072TA

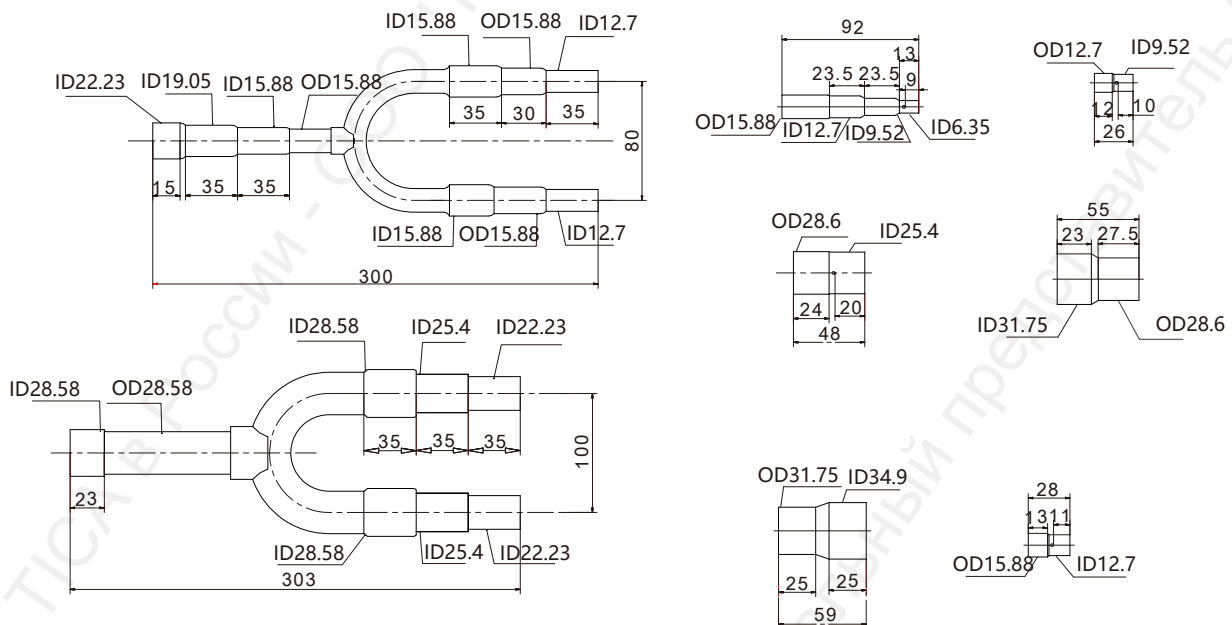

Installation of refrigerant piping

Limits for refrigerant piping

Capacity combination

$$50\% \leq \frac{\Sigma \text{ Rated cooling capacity of IDU}}{\text{Rated cooling capacity of ODU}} \leq 130\%$$

Remarks: It is recommended that the above value shall not be greater than 100% when selecting models. For scenarios with lower simultaneous usage coefficient, the above value may exceed 100%.

Unit capacity		Single unit
Maximum equivalent piping length		≤ 400 m
Level difference	Level difference between IDU and ODU	H1 ≤ 50 m (when the ODU is at the upper position)
		H1 ≤ 40 m (when the ODU is at the lower position)
	Level difference among IDUs	H2 ≤ 30 m

Note (1): Equivalent length is the converted length after taking into account of pressure losses at elbows.

Equivalent length = actual pipe length + number of elbows × equivalent length of each elbow

Equivalent length of every place of branch pipe is 0.5 m, and please refer to the following table for equivalent length of elbows.

Pipe diameter	Equivalent length
	Elbow (m)
φ 9.52	0.18
φ 12.7	0.2
φ 15.88	0.25
φ 19.05	0.35
φ 22.23	0.4
φ 25.4	0.45
φ 28.6	0.5
φ 31.8	0.55

Precautions when breaking through the knockout

- Do not damage the unit shell when trying to break through the knockout.
- Ensure the hole to be trimmed after being broke through with a hammer, and protect it from corrosion by painting.
- When passing the wire through knockout, put grommet in the hole or wrap wires with adhesive tape for protection.

Air tightness test, vacuuming and supplementing refrigerant

For TICS units, vacuum pump, pressure gauge, compound pressure gauge and charging hose used for R410A refrigerant are different from those used for R22 refrigerant. Make sure to use R410A dedicated tools.

Air tightness test

Caution:

- After piping work is completed, make sure to do air tightness test for IDU and piping.
- Do not use flammable gas or air (oxygen) as pressurized gas, otherwise fire or explosion may be caused; use nitrogen only.

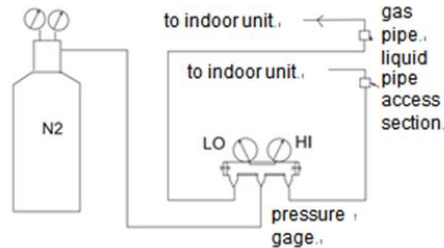

Steps:

Step 1: Use a vacuum pump to discharge air out of the system from the spool of liquid-side check valve. Hold gauge pressure at -1kgf/cm^2 for one hour. If pressure rises, there may be moisture or leakage in the system; Otherwise, proceed to the next step.
 Step 2: Close the vacuum pump, increase the pressure by 0.3MPa from the spool of the gas-/liquid-side check valve and hold it for 3 minutes. Check whether there are large leakage points.
 Step 3: Continue to increase pressure to 1.5 MPa for three minutes, and check whether there are minor leakage points.
 Step 4: Continue to increase pressure to 4.0 MPa for 24 hours, and check whether there are micro leakage points

Caution:

- Use nitrogen in air tightness test instead of oxygen, flammable and toxic gas, or water.
- Use R410A dedicated pressure gauge, with measuring range above 4.5 MPa.
- Connect high pressure pipe and low pressure pipe and increase pressure for them at the same time, without connecting to ODU.
- After passing air tightness test, if not used immediately, release system pressure to 0.2-0.3 MPa and then seal it.

Vacuuming

- Use vacuum pump with volume above 4 L/s. The vacuum degree must support -755 mmHg and lower.
- To prevent lubricating oil from flowing in the reverse direction to refrigerant system, use vacuum pump with electronic one-way valve.
- Vacuum air pipe and liquid pipe at the same time. Before vacuuming, make sure again that stop valves at air and liquid sides of IDUs are closed.
- Use R410A dedicated tools, such as pressure gauge and liquid supplementing pipe.

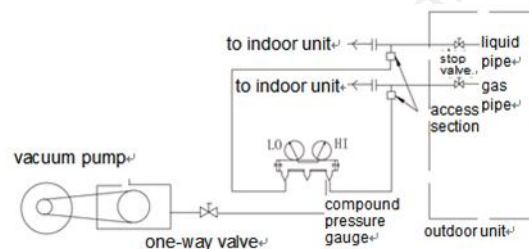

Air tightness test, vacuuming and supplementing refrigerant

Supplementing refrigerant

Principles:

Before delivery, the ODUs have been filled with a certain amount of refrigerant, but which cannot meet the needs of extended pipes. So refrigerant has to be added according to the actual length of refrigerant piping at installation site.

Steps:

- Close compound pressure gauge, replace vacuum pump with filling tank connected with charging pipe. Make sure the air is drained completely, and connect the joints of filling tanks and put the tank mouth down on the platform scale.
- Set the quantity to be filled at the electronic scale, and successively open the valve of filling tank and valve of compound pressure gauge to fill the system with refrigerant. When reaching the limits, immediately close valve of filling tank and disconnect connection pipes.

Caution:

- For refrigerant tank with siphon: the tank needs not to be put upside down because the siphon can reach the tank bottom.
- If using R410A filling tank without siphon, make sure the tank is put upside down in the filling process, which is shown as below

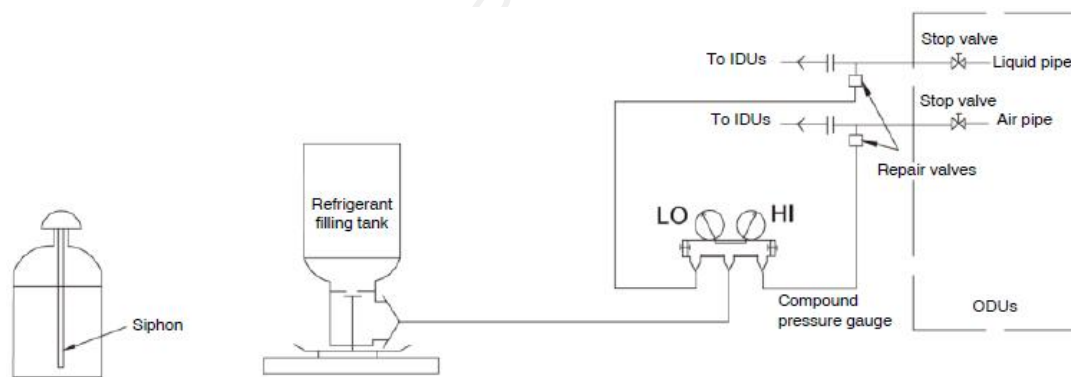

Calculation of amount to be filled (R410A):

Liquid pipe diameter (mm)	6.35	9.52	12.7	15.88	19.05	22.23
Supplemented refrigerant quantity (g/m)	22	57	110	170	260	360

Supplemented refrigerant quantity = Σ liquid pipe length at various diameters \times supplemented refrigerant quantity per meter

Electrical control installation

Wiring cautions

Cautions for power wiring

- Use copper wire as power wire and do not make it too tight.
- The indoor and outdoor units use different circuit loop: three-phase for outdoor unit, and single-phase for indoor unit.
- All the IDUs and ODUs of the same system must be supplied with power simultaneously.
- The distribution box shall be provided with a set of electric leakage protection device and air switch for each module.
- Make sure all the earth lines of the unit are connected to ground securely. Do not connect earth lines to lightning devices, telephone line, gas pipe or tap water pipe. Improper grounding may cause electrical shock or fire.

Cautions for communication line wiring

- TICS series independent inverter VRF air conditioning unit has both high voltage (power) line and control (communication) line. Do not connect power line to the connecting terminal of communication cables!
- The total length of communication line is less than 1000 m.
The shielding layer of communication line must be connected to earth lines of each module and IDUs securely.

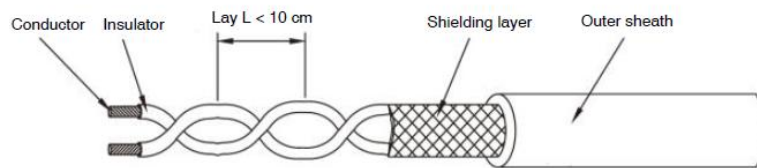

Legends of shielded twisted pair

- Communication lines are well connected before power on.
- Do not remove the power plug with power on, lest the communication chips would be damaged. To prevent high voltage signal from disturbing control signal, shielded twisted pair must be used.
- Try to select shielded twisted pair with dense shielding layers and smaller lay. Control signal has two polarities A and B, and different polarities cannot be connected, otherwise communication failures may be caused;

As shown in the figure below.

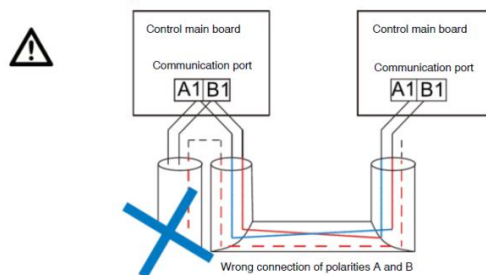

- When power line is parallel with communication line, they shall be covered by respective conduits and kept at some distance away.



Electrical control installation

Wiring specifications

Notes:

- As wires need to be bent during installation process, it is recommended to use flexible wires, otherwise installation may fail.
- The parameters in the table below are corresponding to multiple strands of flexible copper wires. If other wires are selected, please refer to electrician's manual based on wiring current provided in the table.
- For safety purpose, do not carry out wiring work based on rated current, for the operating conditions may be varied with seasons.

Table of ODU wiring specification

ODU model	Power supply	Voltage range (V)	Fuse circuit breaker (A)	General power line	Length (m)	Earth line	Communication line
TIMS252CSREA	Three-phase 380V/50Hz	418/342	30	6 mm ²	≤20	6 mm ²	0.75-1.25 mm ² polyethylene shielded twisted pair
				10 mm ²	20-50	10 mm ²	
TIMS285CSREA		418/342	30	6 mm ²	≤20	6 mm ²	
				10 mm ²	20-50	10 mm ²	
TIMS335CSREA		418/342	30	6 mm ²	≤20	6 mm ²	
				10 mm ²	20-50	10 mm ²	

Electrical control installation

Electrical wiring

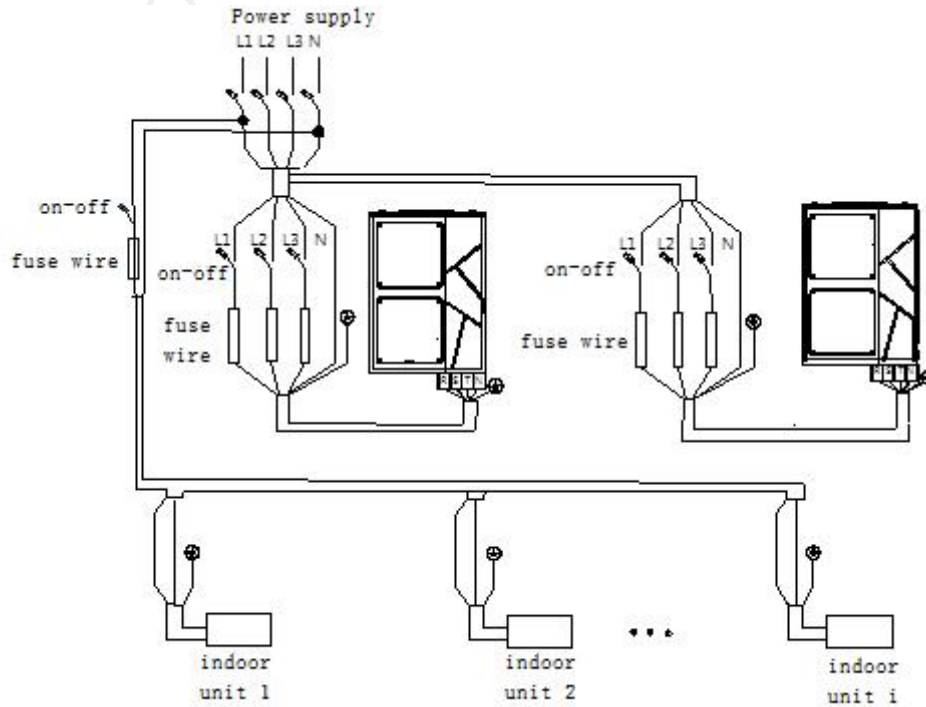

Communication wiring

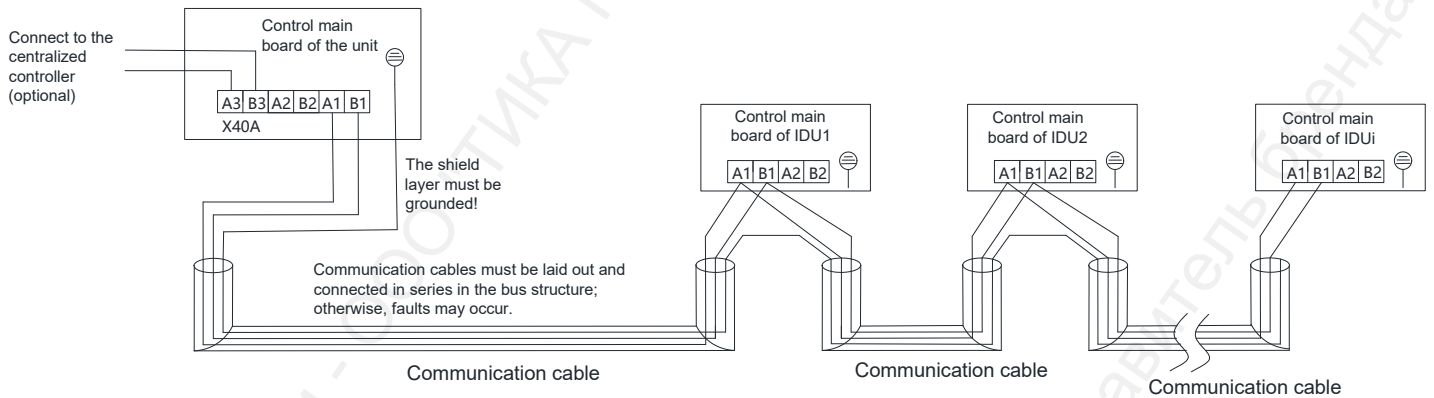
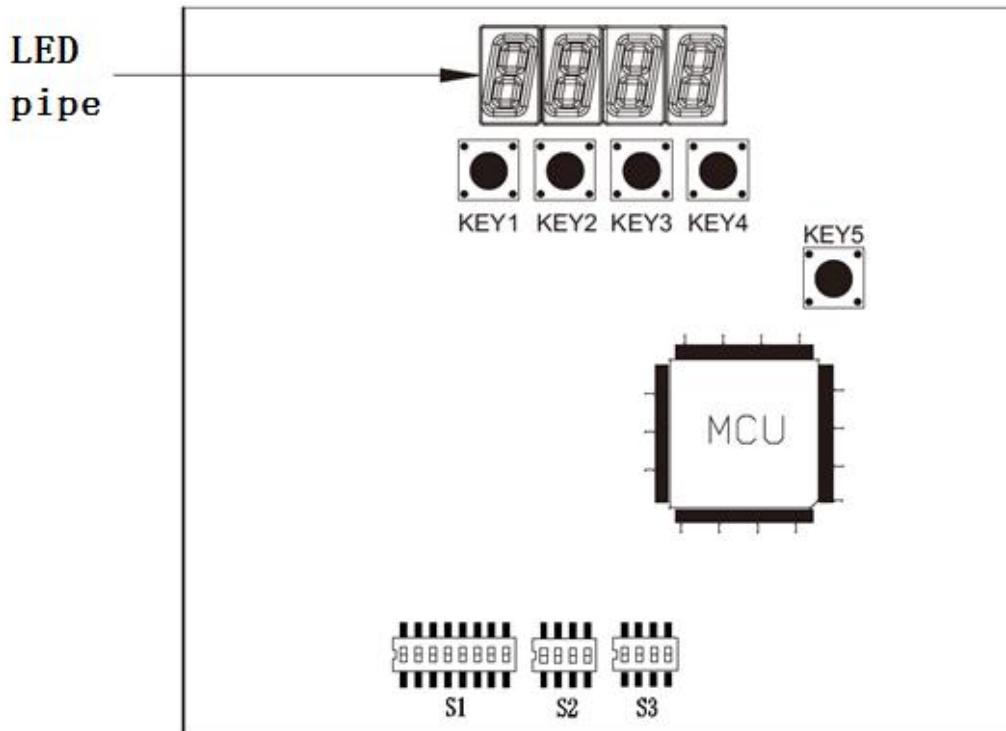
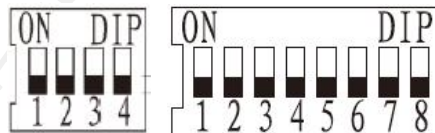

Illustration on control board of ODUs



Code settings

Notes:



- "0" for the status above, and "1" when dialed to the "ON" position.
- Description on ODU address setting: based on the specific situation after installation is completed.
- The unit must be powered on again after the DIP switch is reset.
- ODU capacity code has been set properly before delivery. Please check whether the setting is right.



Illustration on control board of ODUs

- S1: ODU capacity code (reserved)

Meaning/DIP	S1-5	S1-6	S1-7	S1-8
CXREA	0	0	0	0

- S2: System set DIP switch. The group is reserved by default
- S3: DIP switch of ODU capacity

Capacity/DIP	S3-1	S3-2	S3-3	S3-4
252	0	0	0	1
285	0	0	1	0
335	0	0	1	1



Illustration on control board of ODUs

Settings of relevant keys

1) Contents

1. SP01: address setting under centralized monitoring, AR01, AR02...AR99;
2. SP02: setting of centralized monitoring of baud rate;
3. SP03: silent mode
4. SP04: selecting of compressor drive manufacturer (default)
5. SP05: selecting of fan drive manufacturer (default)
6. SP06: selecting of compressor manufacturer (default)
7. SP07: selecting of fan manufacturer (default)
- 8) SP08: selecting of user mode;
- 9) SP09: manual power on/off;
- 10) SP10: manual address clearing;
- 11) SP11: manual oil return
- 12) SP12: reserved

2) Buttons and corresponding label

Buttons: KEY1, KEY2, KEY3, KEY4 and KEY5

Shown icons:

- 1) KEY1: Click KEY1 menu key and set parameters;
- 2) KEY2/KEY3: After entering the second-level menu item, click KEY2/KEY3 to turn up and down, and click KEY4 to confirm to enter the next level of menu items;
- 3) KEY4: confirm key;
- 4) KEY5: reset key;
- 5) SP**: indicates the parameter number, where ** indicates the specific parameter number (01, 02... 11, 12);
- 6) SP01→Ar**: indicates the address of device for centralized monitoring, where ** indicates the specific address (01, 02... 98, 99);
- 7) SP02→b***: indicates the baud rate of centralized communication, where *** indicates the specific address (96, 192), and the corresponding baud rates are 9600 and 19200 respectively;
- 8) SP03:
 - 0: qoFF non-silent mode;
 - 1: qoN1 auto silent mode (with temperature trend control);

- 2: qoN2 smart silent mode;
 - 3: qoN3 forced silent mode 1;
 - 4: qoN4 forced silent mode 2;
 - 5: qoN5 forced silent mode 3;
 - 6: qoN6 forced silent mode 4;
- 9) SP08:
- 0: od-0 represents giving priority to the existing operating mode;
 - 1: od-1 represents the VIP mode;
 - 2: od-2 represents the cooling priority mode;
 - 3: od-3 represents the heating priority mode;
 - 4: od-4 represents the cooling-only mode;
 - 5: od-5 represents the heating-only mode;
- 10) SP09: 0003 cooling fully on, 0004 cooling fully off, 0009 heating fully on, 0010 heating fully off;
- 11) SP10: manually address clear, select "0033", and then confirm with K4.

3) Description of specific operations

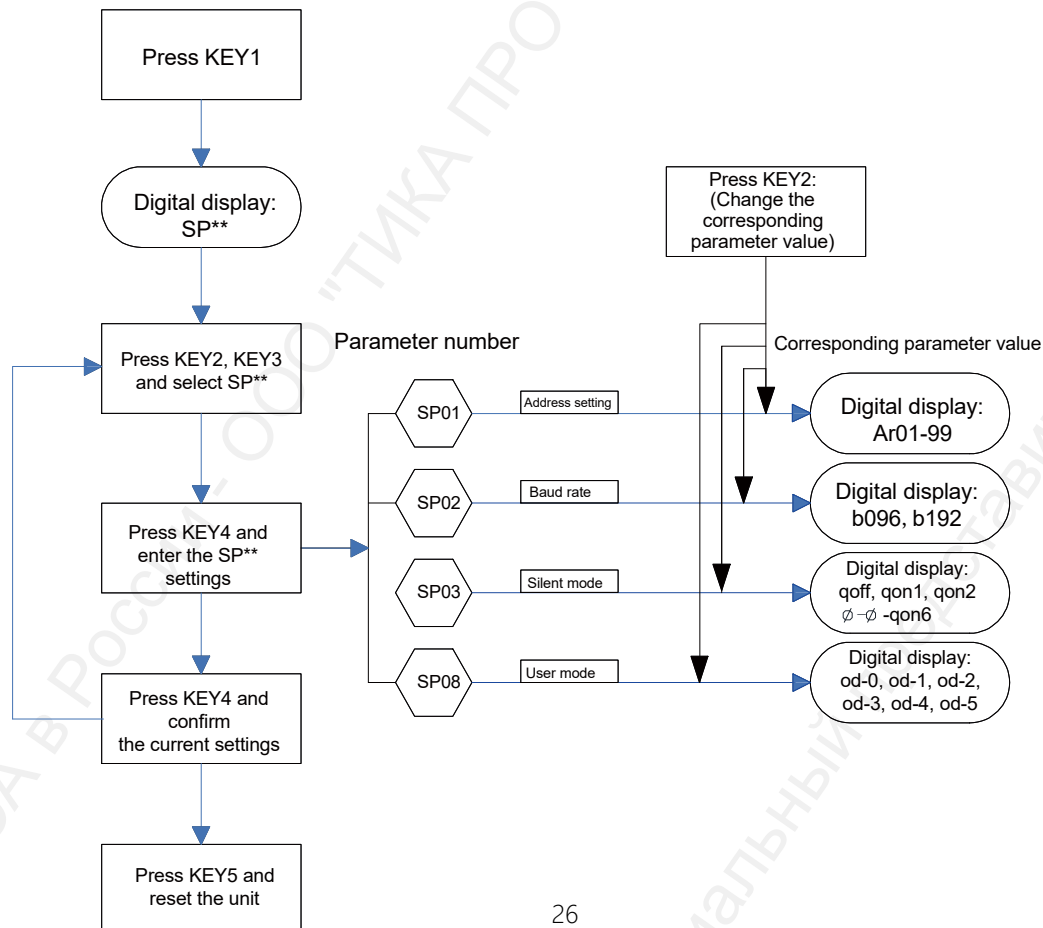

Illustration on control board of ODU's

Digital display

- Description of contents displayed on digital tubes

Note	0	1	2	3	4	5	6	7	8	9
Digital tube display	0	1	2	3	4	5	6	7	8	9
Note	A	B	C	D	E	F	G	H	I	J
Digital tube display	A	B	C	D	E	F	G	H	I	J
Note	L	N	O	P	R	S	T	U	Y	
Digital tube display	L	N	O	P	R	S	T	U	Y	

When operation mode varies, digital tube will display the new mode correspondingly; normally it will display this mode for five seconds before displaying real-time clock; in the case of malfunctions, it will display the current malfunction code.

- Table of fault codes of digital tubes

Code	content	handling
E000	INV1 high pressure switch-off	Outdoor unit stop
E001	FAN1 drive error	1# compressor stop
E002	INV1 drive overload	1# compressor stop
E003	INV1 exhaust temperature over heat	1# compressor stop
E004	INV1 drive communication error	1# compressor stop
E005	FAN1 drive communication error	1# compressor stop
E006	INV1 drive over heat error	1# compressor stop
E007	INV1 drive error	1# compressor stop
E008	Ambient temperature sensor THo1 error	Outdoor unit stop
E009	1# compressor exhaust temperature sensor THo2 error	1# compressor stop
E010	Suction temperature sensor THo3 error	Protection mode
E011	Tho4 fault of inlet temperature sensor at the auxiliary side of plate heat exchanger	Protection mode
E012	THo5 fault of outlet temperature sensor at the auxiliary side of plate heat exchanger	Protection mode

E013	THo6 fault of outlet temperature sensor at the main side of plate heat exchanger	Protection mode
E014	THo7 fault of temperature sensor of defrosting temperature point	Outdoor unit stop
E015	1# compressor exhaust temperature sensor THo8 error	2# compressor stop
E016	1# compressor top temperature sensor FCo1 fault	1 # compressor stop
E017	2# compressor top temperature sensor FCo2 fault	2# compressor stop
E018	Reserved	
E019	Reserved	
E020	Abnormal capacity distribution between IDU and ODU	Outdoor unit stop
E021	Low pressure sensor error	Outdoor unit stop
E022	High pressure sensor error	Outdoor unit stop
E023	Phase-sequence error	Outdoor unit stop
E024	INV2 high pressure switch-off	Outdoor unit stop
E025	FAN2 drive error	2# compressor stop
E026	INV2 drive overload	2# compressor stop
E027	INV2 exhaust temperature over heat	2# compressor stop
E028	INV2 drive communication error	2# compressor stop
E029	FAN2 drive communication error	2# compressor stop
E030	INV2 drive over heat error	2# compressor stop
E031	INV2 drive error	2# compressor stop
E032	Shortage of differential pressure	Outdoor unit stop
E033	INV1 Exhaust overheat too low or too high	Operating after 30 min outdoor unit stop
E034	High pressure too low	Outdoor unit stop
E035	Low pressure too low	Outdoor unit stop
E036	INV2Exhaust overheat is too low or too high	Operating after 10 min outdoor unit stop
E037	Ambient temperature exceed limit	Outdoor unit stop, operating after temperature recovery
E038	No communication between indoor/outdoor unit	Outdoor unit stop
E039	System error	Outdoor unit stop. If there comes 3 times hints of low/high pressure overload in 2 hour, you need to re-apply power to start.

ECXX is indoor unit communication error, EC00 is 0# indoor unit, EC01 is 1# indoor unit...and followings can be done in a similar manner.

Trial Operation

Before trial operation

Make sure to check:

- Installation
 - ◆ Whether the air conditioning unit can be securely fixed at the site.
 - ◆ Whether the place is well ventilated and large enough for maintenance.
 - ◆ Whether the number of IDUs connected to ODU is allowable.
- Wiring
 - ◆ Whether the insulation for the loop of main power supply is intact.

Check insulation status against national regulations.

 - ◆ Whether power cord and communication cable have allowable length.
 - ◆ Whether communication cable and power cord are connected correctly and fastened securely.
- Piping
 - ◆ Whether refrigerant piping is dimensionally correct.
 - ◆ Whether refrigerant piping is correctly connected and has reasonable length.
 - ◆ Whether refrigerant piping and drainage pipe are insulated correctly.
- Code

Whether the codes for capacity of control panel for IDU and ODU, and for addresses are correct and set with corresponding numbers (S1, S2 and S3 and so on).

Trial Operation

- Open all the stop valves completely.
- Connect the power supply:

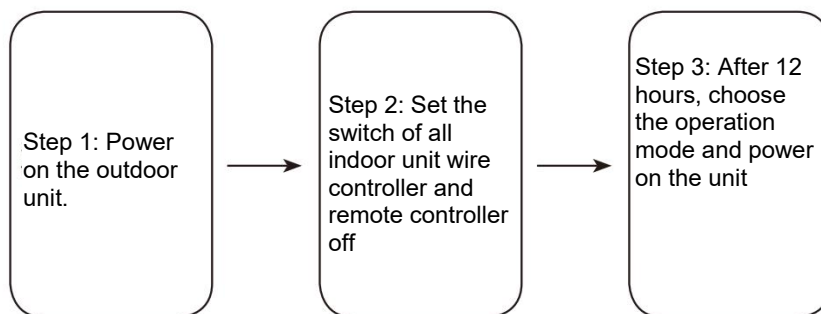

- Communication check:

Communication check: Observe whether the communication indicator light of the ODU flashes regularly. The 4-digit eight-segment digital display shows the number of IDUs searched out. Compare the number of IDUs searched out with the actual number of IDUs. The consistency in number indicates good communication connection.



Trial Operation

Trial operation check

Start cooling or heating operation using a wired controller or remote controller.

- After 5 minutes, check whether there is cold (hot) air from IDU.
- Check all the IDUs in the same way.
- If any wiring or piping errors are found, please correct the errors and start trial operation again.

Note

- Start another IDU one minute before the current IDU stops, which could save trial operation time.
- Please refer to the following allowable operation range under various operation modes. The system cannot operate normally if exceeding limits.

Mode	Outdoor ambient temperature
Cooling	-5°C-56°C (dry bulb)
Heating	-27°C-26°C (wet bulb)



Description of hazardous substances

Environmental Protection Description

This product complies with the environmental protection requirements of the Measures for the Administration of the Restricted Use of the Hazardous Substances Contained in Electrical and Electronic Products.

Environmental protection service life: In the environmental protection service life, the user's normal use of this product will not cause serious pollution to the environment or cause serious damages to persons and properties. The service life is specified by TICA. The environmental protection service life is not equivalent to the service life of safe use.

Recycling: When this product is not needed or its service life ends, recycle it according to the related national regulations on recycling of waste electrical and electronic products. Do not discard it at will.

Names and content of hazardous substances in products

Part name	Hazardous substance					
	Plumbum (Pb)	Mercury (Hg)	Cadmium (Cd)	Hexavalent chromium (Cr(VI))	Polybrominated biphenyl (PBB)	Polybrominated diphenyl ether (PBDE)
Compressor and its accessories	×	○	×	○	○	○
Refrigerant	○	○	○	○	○	○
Motor	×	○	○	○	○	○
Heat exchanger	×	○	×	○	○	○
Pipeline fittings and valves	×	○	○	○	○	○
Screws, bolts, and other fasteners	○	○	○	×	○	○
Other metal parts	×	○	○	×	○	○
Controller and electrical components	×	○	○	○	○	○
Sponge	○	○	○	○	○	○
Foam	○	○	○	○	○	○
Rubber parts	○	○	○	○	○	○

Electric heating components	×	○	○	○	○	○
Other printed matters	○	○	○	○	○	○

This table is prepared according to the provisions of SJ/T 11364.

O: It indicates that the content of this hazardous substance in all homogeneous materials of the component is below the limit specified in GB/T 26572.

×: It indicates that the content of the hazardous substance in at least one homogeneous material of the component exceeds the limit specified in GB/T 26572, and cannot be replaced for technical reasons. This problem will be gradually solved with the progress of technology.

*: It indicates that the environmental-protection service life of the battery matched with the product is 2 years.

The number in this identification indicates that the environmental protection service life of the product under the normal use status is 15 years. Some parts may also have the identification of environmental protection service life, and their environmental protection service life is subject to the number in the identification. The product configuration may be different due to different models or product improvements. The actual configuration of sold products should prevail.





**ООО «ТИКА ПРО»
(TICA PRO LLC)**

Тел.: +7 495 127 79 00,
+7 915 650 85 85,
+7 969 190 85 85

E-mail: info@tica.pro

www.tica.pro